

YOUR
OWN
STYLE

WALK IN Shower enclosures.



Finiture / Finishes / Acabados / Finitions / Afwerkingen / Ausführungen

Telaio / Frame / Bastidor / Profilé / Frame / Rahmen

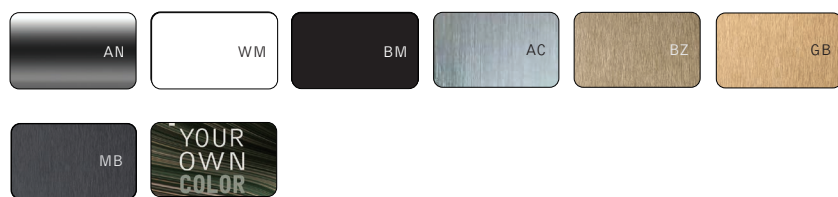

Vetro / Glass / Vidrio / Verre / Glas / Glas



Modelli / Models / Modelos / Modèles / Modellen / Modelle

Pareti 8 mm / Panels 8 mm / Parois 8 mm / Paredes 8 mm

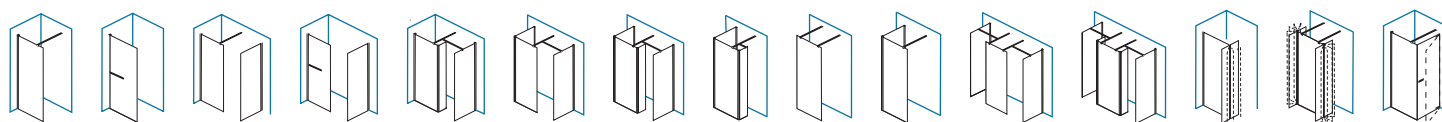

Pareti 6 mm / Panels 6 mm / Parois 6 mm / Paredes 6 mm

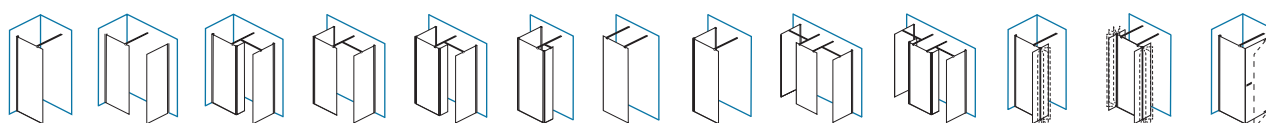

www.inda.net

inda[®]
bathroom interiors



Porta battente di chiusura sinistra / Left pivot door
Porte pivotante gauche / Puerta pivotante izquierda
Draaideur links / Links schliessende Drehtür

H min 150cm / max 220cm
 L min 50cm / max 100cm



Le dimensioni sono in mm / Sizes in mm /
 Les dimensions sont indiquées en mm /
 Las medidas son en mm /
 De afmetingen zijn vermeld in mm / Maßangaben in mm

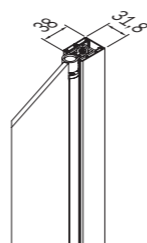
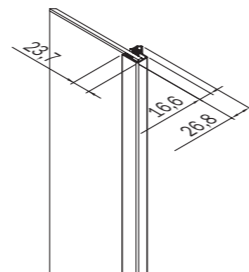
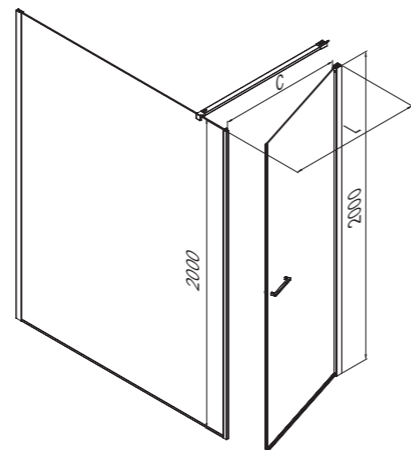

Chiusura magnetica. Apertura totale delle ante verso l'esterno. Guarnizione inferiore. Maniglia int. - est.
 Magnetic closure. Outside opening doors. Bottom seal. Inside-outside handle.
 Fermeture magnétique. Portes s'ouvrant à l'extérieur. Joint inférieur. Poignée intérieur-extérieur.
 Cierre magnético. Puertas de apertura exterior. Sello inferior. manija interior-exterior.
 Magnetische sluiting. Totale opening van de deuren naar buiten toe. Onderste dichting. Handvat binnen en
 buiten. Zonder waterkeringsprofiel.
 Magnetverschluss. Türen lassen sich komplett nach aussen öffnen. Untere Dichtung. Griff intern/estern.

Cod.	L	C	KG	
B259X S	70 - 85,9	62 - 78	25	1
B259Y S	86 - 100	78 - 92	32	1
B259X D	70 - 85,9	62 - 78	25	1
B259Y D	86 - 100	78 - 92	32	1



AN WMBM AC BZ GB MB	01	14	73	41
Larghezza - estensibilità Breadth - extensibility Largeur - extensibilité Ancho - extensibilidad Breedte - aanpassingsvermogen Breite - Anpassungsfähigkeit	cod.	cod.	cod.	cod.
L 70 - 85,9 cm	B259X S AN 011A B259X S WM 011A B259X S BM 011A B259X S 011A	B259X S AN 141A B259X S WM 141A B259X S BM 141A B259X S 141A	B259X S AN 731A B259X S WM 731A B259X S BM 731A B259X S 731A	B259X S AN 411A B259X S WM 411A B259X S BM 411A B259X S 411A
L 86 - 100 cm	B259Y S AN 011A B259Y S WM 011A B259Y S BM 011A B259Y S 011A	B259Y S AN 141A B259Y S WM 141A B259Y S BM 141A B259Y S 141A	B259Y S AN 731A B259Y S WM 731A B259Y S BM 731A B259Y S 731A	B259Y S AN 411A B259Y S WM 411A B259Y S BM 411A B259Y S 411A
AC - BZ - GB - MB	B259X S	B259X S	B259X S	B259X S

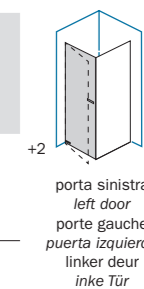

Fornire la misura a partire dal muro all'esterno lastra esistente.
 Please provide the exact measure from the wall to the external side of the existing panel.
 Veuillez fournir la dimension du mur à l'extérieur de la paroi vitrée existante.
 Proporcionar las medidas desde la pared hasta el externo de la hoja cristal existente.
 Geef de afmetingen op te geven: van de muur tot buitenkant van de bestaande glazen wand.
 Bitte Abmessungen angeben von der Wand bis hin zur Aussenseite der vorhandenen Glaswand.

Porta battente di chiusura destra / Right pivot door
Porte pivotante droite / Puerta pivotante derecha
Draaideur rechts / Rechts schliessende Drehtür

H min 150cm / max 220cm
 L min 50cm / max 100cm

Larghezza - estensibilità Breadth - extensibility Largeur - extensibilité Ancho - extensibilidad Breedte - aanpassingsvermogen Breite - Anpassungsfähigkeit	cod.	cod.	cod.	cod.
L 70 - 85,9 cm	B259X D AN 011A B259X D WM 011A B259X D BM 011A B259X D 011A	B259X D AN 141A B259X D WM 141A B259X D BM 141A B259X D 141A	B259X D AN 731A B259X D WM 731A B259X D BM 731A B259X D 731A	B259X D AN 411A B259X D WM 411A B259X D BM 411A B259X D 411A
L 86 - 100 cm	B259Y D AN 011A B259Y D WM 011A B259Y D BM 011A B259Y D 011A	B259Y D AN 141A B259Y D WM 141A B259Y D BM 141A B259Y D 141A	B259Y D AN 731A B259Y D WM 731A B259Y D BM 731A B259Y D 731A	B259Y D AN 411A B259Y D WM 411A B259Y D BM 411A B259Y D 411A
AC - BZ - GB - MB	B259Y D	B259Y D	B259Y D	B259Y D

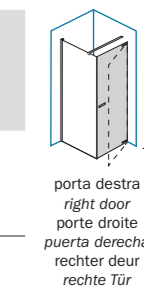

WALK IN

Le dimensioni sono in mm / Sizes in mm /
Les dimensions sont indiquées en mm /
Las medidas son en mm /
De afmetingen zijn vermeld in mm / Maßangaben in mm

