

YOUR  
OWN  
STYLE

# AZURE

The new dimension of shower space.



H200

8mm

## Finiture / Finishes / Acabados / Finitions / Afwerkingen / Ausführungen

Telaio / Frame / Bastidor / Profilé / Frame / Rahmen



Vetro / Glass / Vidrio / Verre / Glas / Glas

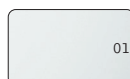

## Modelli / Models / Modelos / Modèles / Modellen / Modelle

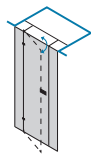
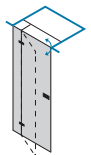
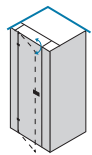
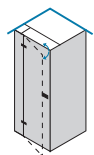

www.inda.net

 **inda**<sup>®</sup>  
bathroom interiors



Le dimensioni sono in mm / Sizes in mm /  
 Les dimensions sont indiquées en mm /  
 Las medidas son en mm /  
 De afmetingen zijn vermeld in mm / Maßangaben in mm

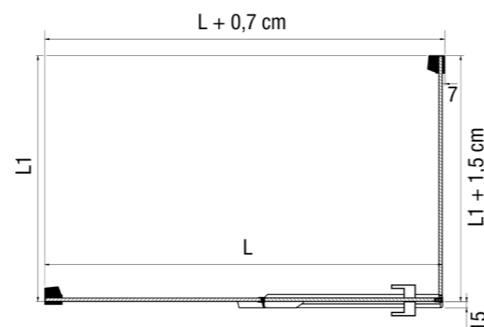
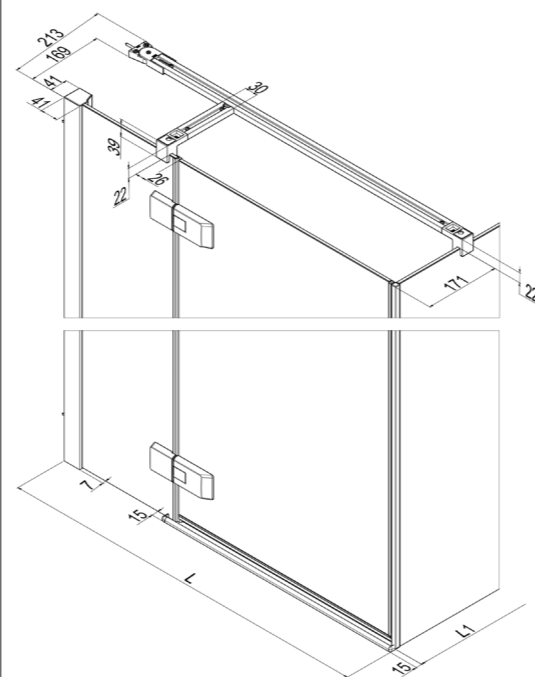
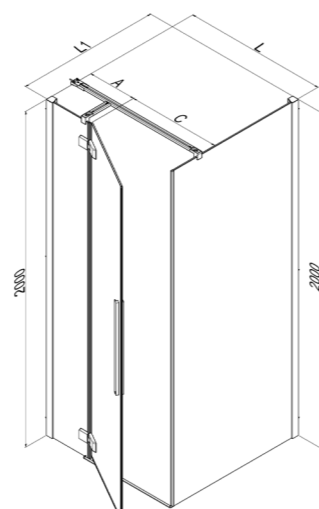

Chiusura magnetica. Apertura totale delle ante sia verso l'interno che verso l'esterno. Guarnizione inferiore. Maniglia inclusa. Nell'imballo sono incluse due guarnizioni per installazione con o senza frangiflutto. Magnetic closure. Fulldoor opening internally and externally. Bottom strip. Handle included. In the packaging two seals for installation with or without water brake are included. Fermeture magnétique. Ouverture totale des portes aussi bien à l'intérieur qu'à l'extérieur. Joint inférieur. Poignée incluse. Dans l'emballage sont compris deux joints pour l'installation avec ou sans brise-flux. Cierre magnético. Apertura total de la puerta interna y externa. Junta inferior. Tirador incluido. En el embalaje están incluidas dos guarniciones para instalación con o sin rompeolas. Magnetische sluiting. Totale opening van de deuren zowel naar buiten als naar binnen toe. Onderstrip. Inclusief greep. In de verpakking zijn twee dichtingen inbegrepen, voor de installatie met of zonder de golfbreker. Magnetverschluss. Totale Türöffnung nach innen und außen. Griff inklusiv. In der Verpackung sind 2 Dichtungen zur Installation mit oder ohne Schwalleiste enthalten.

Cod.	L	L + 0,7	A	B	C	KG	
B9721	76 - 78	76,7 - 78,7	26,1 - 29,1	49	46	41	1
B9722	86 - 88	86,7 - 88,7	29,3 - 32,3	56	53	45	1
B9723	96 - 98	96,7 - 98,7	35,5 - 38,5	60	57	45	1
B9725	116 - 118	116,7 - 118,7	44,3 - 49,3	71	68	68	2
B9727	136 - 138	136,7 - 138,7	64,2 - 67,2	71	68	76	2

Cod.	L1	L1 + 1,5	KG	
B9750	66 - 68 cm	67,5 - 69,5	37	1
B9751	76 - 78 cm	77,5 - 79,5	41	1
B9752	86 - 88 cm	87,5 - 89,5	45	1
B9753	96 - 98 cm	97,5 - 99,5	49	1



AN	01	14
Larghezza - estensibilità Breadth - extensibility Largeur - extensibilité Composición - extensibilidad Breedte - aanpassingsvermogen Breite - Anpassungsfähigkeit	cod.	cod.
L 76 - 78 cm	B9721 S AN 01	B9721 S AN 14
L 86 - 88 cm	B9722 S AN 01	B9722 S AN 14
L 96 - 98 cm	B9723 S AN 01	B9723 S AN 14
L 116 - 118 cm	B9725 S AN 01	B9725 S AN 14
L 136 - 138 cm	B9727 S AN 01	B9727 S AN 14

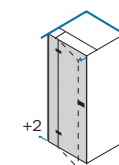

Parete fissa / Fixed panel  
 Paroi fixe / Pared fija  
 Vaste wand / Seitenwand



Larghezza - estensibilità Breadth - extensibility Largeur - extensibilité Composición - extensibilidad Breedte - aanpassingsvermogen Breite - Anpassungsfähigkeit	cod.	cod.
L1 66 - 68 cm	B9750 0 AN 01	B9750 0 AN 14
L1 76 - 78 cm	B9751 0 AN 01	B9751 0 AN 14
L1 86 - 88 cm	B9752 0 AN 01	B9752 0 AN 14
L1 96 - 98 cm	B9753 0 AN 01	B9753 0 AN 14

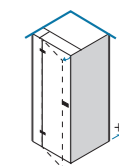

Maniglia / Handle / Poignée / Tiradora / Greep / Griff

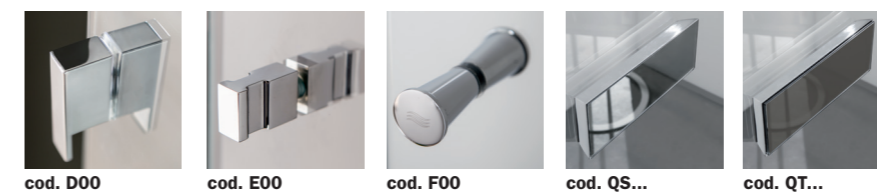

Cerniera / Hinge  
 Charnière / Bisagra  
 Scharnieren / Scharniere

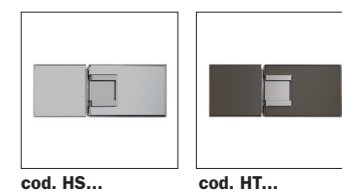



Le dimensioni sono in mm / Sizes in mm /  
 Les dimensions sont indiquées en mm /  
 Las medidas son en mm /  
 De afmetingen zijn vermeld in mm / Maßangaben in mm

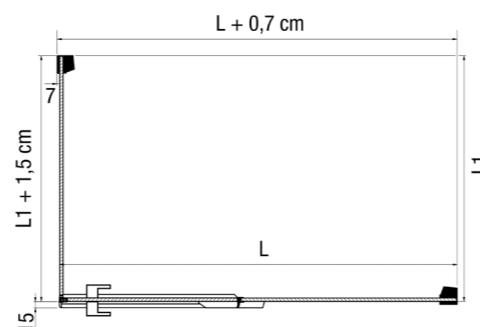
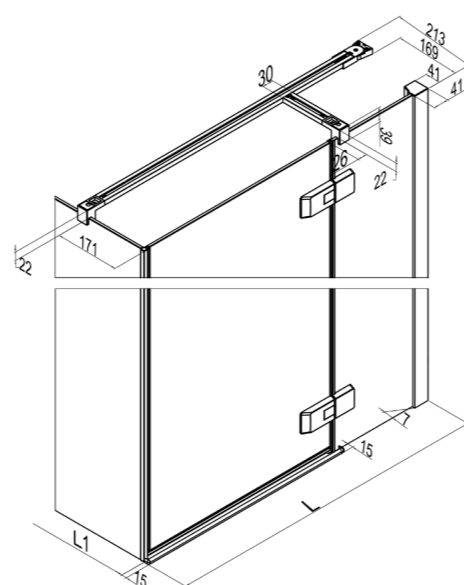
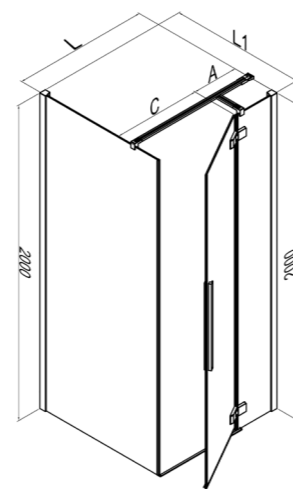

Chiusura magnetica. Apertura totale delle ante sia verso l'interno che verso l'esterno. Guarnizione inferiore. Maniglia inclusa. Nell'imballo sono incluse due guarnizioni per installazione con o senza frangiflutto. Magnetic closure. Fulldoor opening internally and externally. Bottom strip. Handle included. In the packaging two seals for installation with or without water brake are included. Fermeture magnétique. Ouverture totale des portes aussi bien à l'intérieur qu'à l'extérieur. Joint inférieur. Poignée incluse. Dans l'emballage sont compris deux joints pour l'installation avec ou sans brise-flux. Cierre magnético. Apertura total de la puerta interna y externa. Junta inferior. Tirador incluido. En el embalaje están incluidas dos guarniciones para instalación con o sin rompeolas. Magnetische sluiting. Totale opening van de deuren zowel naar buiten als naar binnen toe. Onderstrip. Inclusief greep. In de verpakking zijn twee dichtingen inbegrepen, voor de installatie met of zonder de golfbreker. Magnetverschluss. Totale Türöffnung nach innen und außen. Griff inklusiv. In der Verpackung sind 2 Dichtungen zur Installation mit oder ohne Schwalleiste enthalten.

Cod.	L	L + 0,7	A	B	C	KG	
B9721	76 - 78	76,7 - 78,7	26,1 - 29,1	49	46	41	1
B9722	86 - 88	86,7 - 88,7	29,3 - 32,3	56	53	45	1
B9723	96 - 98	96,7 - 98,7	35,5 - 38,5	60	57	45	1
B9725	116 - 118	116,7 - 118,7	44,3 - 49,3	71	68	68	2
B9727	136 - 138	136,7 - 138,7	64,2 - 67,2	71	68	76	2

Cod.	L1	L1 + 1,5	KG	
B9750	66 - 68 cm	67,5 - 69,5	37	1
B9751	76 - 78 cm	77,5 - 79,5	41	1
B9752	86 - 88 cm	87,5 - 89,5	45	1
B9753	96 - 98 cm	97,5 - 99,5	49	1

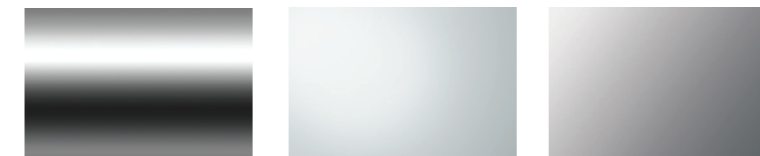

AN	01	14
Larghezza - estensibilità Breadth - extensibility Largeur - extensibilité Composición - extensibilidad Breedte - aanpassingsvermogen Breite - Anpassungsfähigkeit	cod.	cod.
<b>L 76 - 78 cm</b>	B9721 D AN 01	B9721 D AN 14
<b>L 86 - 88 cm</b>	B9722 D AN 01	B9722 D AN 14
<b>L 96 - 98 cm</b>	B9723 D AN 01	B9723 D AN 14
<b>L 116 - 118 cm</b>	B9725 D AN 01	B9725 D AN 14
<b>L 136 - 138 cm</b>	B9727 D AN 01	B9727 D AN 14

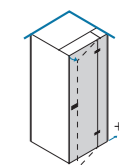

Parete fissa / Fixed panel  
 Paroi fixe / Pared fija  
 Vaste wand / Seitenwand



H max 217cm  
 L min 29cm/max 150cm

Larghezza - estensibilità Breadth - extensibility Largeur - extensibilité Composición - extensibilidad Breedte - aanpassingsvermogen Breite - Anpassungsfähigkeit	cod.	cod.
<b>L1 66 - 68 cm</b>	B9750 0 AN 01	B9750 0 AN 14
<b>L1 76 - 78 cm</b>	B9751 0 AN 01	B9751 0 AN 14
<b>L1 86 - 88 cm</b>	B9752 0 AN 01	B9752 0 AN 14
<b>L1 96 - 98 cm</b>	B9753 0 AN 01	B9753 0 AN 14

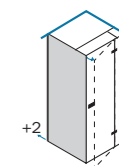

Maniglia / Handle / Poignée / Tiradora / Greep / Griff



Cerniera / Hinge  
 Charnière / Bisagra  
 Scharnieren / Scharniere

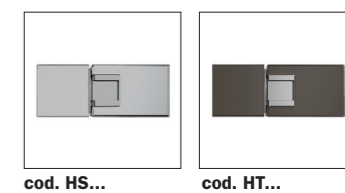

Le dimensioni sono in mm / Sizes in mm /  
Les dimensions sont indiquées en mm /  
Las medidas son en mm /  
De afmetingen zijn vermeld in mm / Maßangaben in mm

Le dimensioni sono in mm / Sizes in mm /  
Les dimensions sont indiquées en mm /  
Las medidas son en mm /  
De afmetingen zijn vermeld in mm / Maßangaben in mm

