

YOUR
OWN
STYLE

AZURE

The new dimension of shower space.

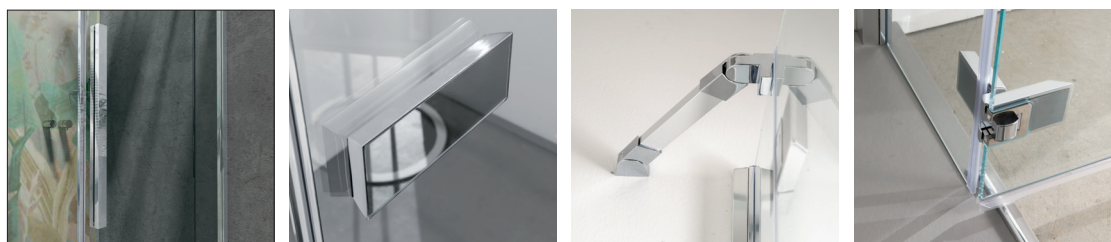

H200

8mm

Finiture / Finishes / Acabados / Finitions / Afwerkingen / Ausführungen

Telaio / Frame / Bastidor / Profilé / Frame / Rahmen



AN

Vetro / Glass / Vidrio / Verre / Glas / Glas

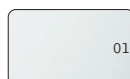

01



14

Modelli / Models / Modelos / Modèles / Modellen / Modelle

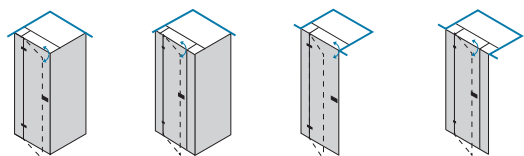

www.inda.net

 **inda**[®]
bathroom interiors



Le dimensioni sono in mm / Sizes in mm /
 Les dimensions sont indiquées en mm /
 Las medidas son en mm /
 De afmetingen zijn vermeld in mm / Maßangaben in mm

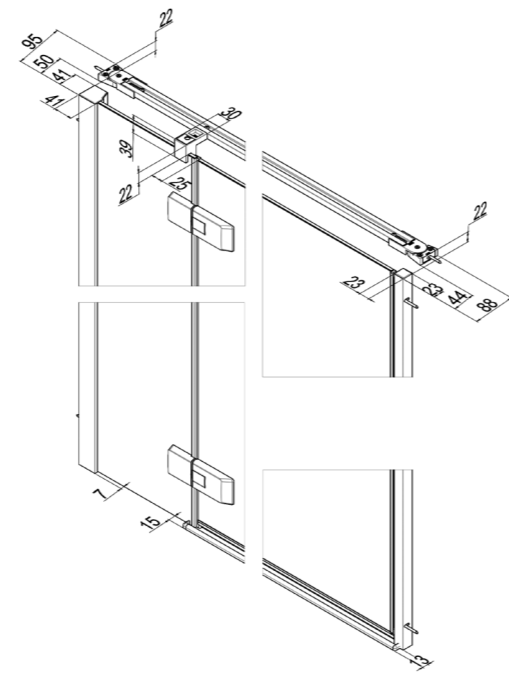
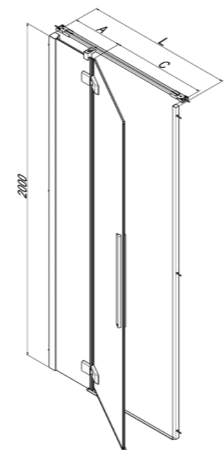

AN	01	14
Larghezza - estensibilità Breadth - extensibility Largeur - extensibilité Composición - extensibilidad Breedte - aanpassingsvermogen Breite - Anpassungsfähigkeit	cod.	cod.
L 77,5 - 80,5 cm	B9701 S AN 01	B9701 S AN 14
L 87,5 - 90,5 cm	B9702 S AN 01	B9702 S AN 14
L 97,5 - 100,5 cm	B9703 S AN 01	B9703 S AN 14
L 117,5 - 120,5 cm	B9705 S AN 01	B9705 S AN 14
L 137,5 - 140,5 cm	B9707 S AN 01	B9707 S AN 14

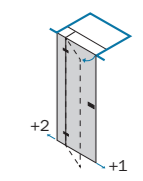

Chiusura magnetica. Apertura totale delle ante sia verso l'interno che verso l'esterno. Guarnizione inferiore. Maniglia inclusa. Nell'imballo sono incluse due guarnizioni per installazione con o senza frangiflutto.
 Magnetic closure. Fulldoor opening internally and externally. Bottom strip. Handle included. In the packaging two seals for installation with or without water brake are included.
 Fermeture magnétique. Ouverture totale des portes aussi bien à l'intérieur que à l'extérieur. Joint inférieur. Poignée incluse. Dans l'emballage sont compris deux joints pour l'installation avec ou sans brise-flux.
 Cierre magnético. Apertura total de la puerta interna y externa. Junta inferior. Tirador incluido. En el embalaje están incluidas dos guarniciones para instalación con o sin rompeolas.
 Magnetische sluiting. Totale opening van de deuren zowel naar buiten als naar binnen toe. Onderstrip. Inclusief greep. In de verpakking zijn twee dichtingen inbegrepen, voor de installatie met of zonder golfbreker.
 Magnetverschluss. Totale Türöffnung nach innen und außen. Griff inklusiv. In der Verpackung sind 2 Dichtungen zur Installation mit oder ohne Schwalleiste enthalten.

Cod.	L	A	B	C	KG	
B9701	77,5 - 80,5	26,1 - 29,1	49	46	41	1
B9702	87,5 - 90	29,3 - 32,3	56	53	45	1
B9703	97,5 - 100,5	35,5 - 38,5	60	57	49	1
B9705	117,5 - 120,5	44,3 - 49,3	71	68	68	2
B9707	137,5 - 140,5	64,2 - 67,2	71	68	76	2

Maniglia / Handle / Poignée / Tiradora / Greep / Griff

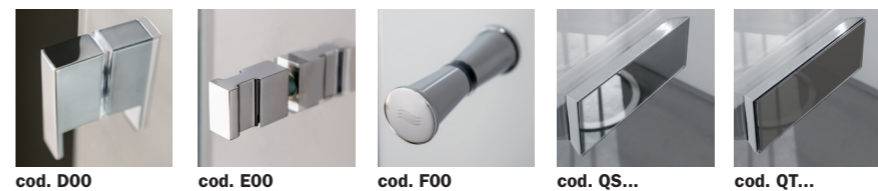

Cerniera / Hinge
 Charnière / Bisagra
 Scharnieren / Scharniere

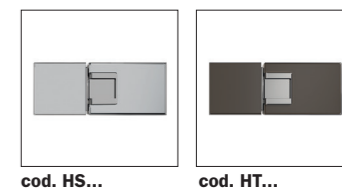



Le dimensioni sono in mm / Sizes in mm /
 Les dimensions sont indiquées en mm /
 Las medidas son en mm /
 De afmetingen zijn vermeld in mm / Maßangaben in mm

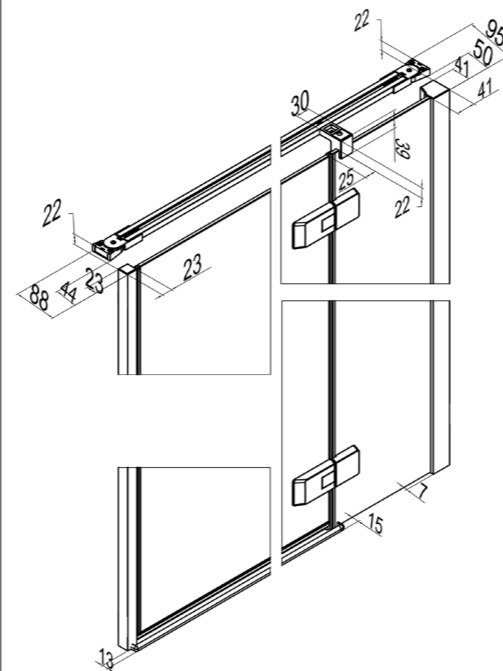
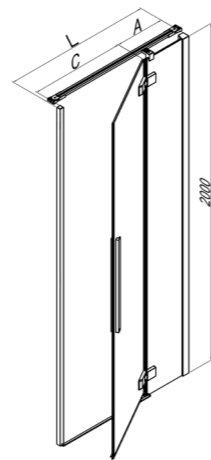

AN	01	14
Larghezza - estensibilità Breadth - extensibility Largeur - extensibilité Composición - extensibilidad Breedte - aanpassingsvermogen Breite - Anpassungsfähigkeit	cod.	cod.
L 77,5 - 80,5 cm	B9701 D AN 01	B9701 D AN 14
L 87,5 - 90,5 cm	B9702 D AN 01	B9702 D AN 14
L 97,5 - 100,5 cm	B9703 D AN 01	B9703 D AN 14
L 117,5 - 120,5 cm	B9705 D AN 01	B9705 D AN 14
L 137,5 - 140,5 cm	B9707 D AN 01	B9707 D AN 14

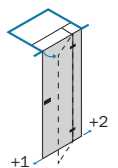

Chiusura magnetica. Apertura totale delle ante sia verso l'interno che verso l'esterno. Guarnizione inferiore. Maniglia inclusa. Nell'imballo sono incluse due guarnizioni per installazione con o senza frangiflutto.
 Magnetic closure. Fulldoor opening internally and externally. Bottom strip. Handle included. In the packaging two seals for installation with or without water brake are included.
 Fermeture magnétique. Ouverture totale des portes aussi bien à l'intérieur que à l'extérieur. Joint inférieur. Poignée incluse. Dans l'emballage sont compris deux joints pour l'installation avec ou sans brise-flux.
 Cierre magnético. Apertura total de la puerta interna y externa. Junta inferior. Tirador incluido. En el embalaje están incluidas dos guarniciones para instalación con o sin rompeolas.
 Magnetische sluiting. Totale opening van de deuren zowel naar buiten als naar binnen toe. Onderstrip. Inclusief greep. In de verpakking zijn twee dichtingen inbegrepen, voor de installatie met of zonder de golfbreker.
 Magnetverschluss. Totale Türöffnung nach innen und außen. Griff inklusiv. In der Verpackung sind 2 Dichtungen zur Installation mit oder ohne Schwalleiste enthalten.

Cod.	L	A	B	C	KG	
B9701	77,5 - 80,5	26,1 - 29,1	49	46	41	1
B9702	87,5 - 90	29,3 - 32,3	56	53	45	1
B9703	97,5 - 100,5	35,5 - 38,5	60	57	49	1
B9705	117,5 - 120,5	44,3 - 49,3	71	68	68	2
B9707	137,5 - 140,5	64,2 - 67,2	71	68	76	2

Maniglia / Handle / Poignée / Tiradora / Greep / Griff



Cerniera / Hinge
 Charnière / Bisagra
 Scharnieren / Scharniere

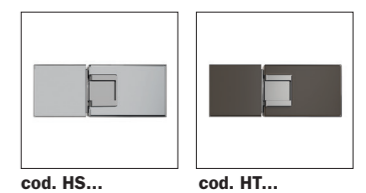

Le dimensioni sono in mm / Sizes in mm /
Les dimensions sont indiquées en mm /
Las medidas son en mm /
De afmetingen zijn vermeld in mm / Maßangaben in mm

Le dimensioni sono in mm / Sizes in mm /
Les dimensions sont indiquées en mm /
Las medidas son en mm /
De afmetingen zijn vermeld in mm / Maßangaben in mm

