

YOUR  
OWN  
STYLE

# WALK IN

Free space.



H200

6mm

8mm

## Finiture / Finishes / Acabados / Finitions / Afwerkingen / Ausführungen

Telaio / Frame / Bastidor / Profilé / Frame / Rahmen

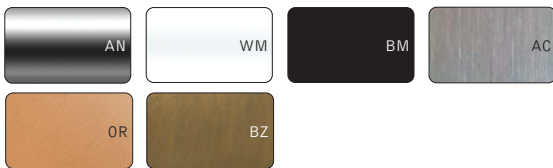

Vetro / Glass / Vidrio / Verre / Glas / Glas

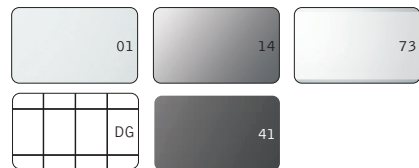

## Modelli / Models / Modelos / Modèles / Modellen / Modelle

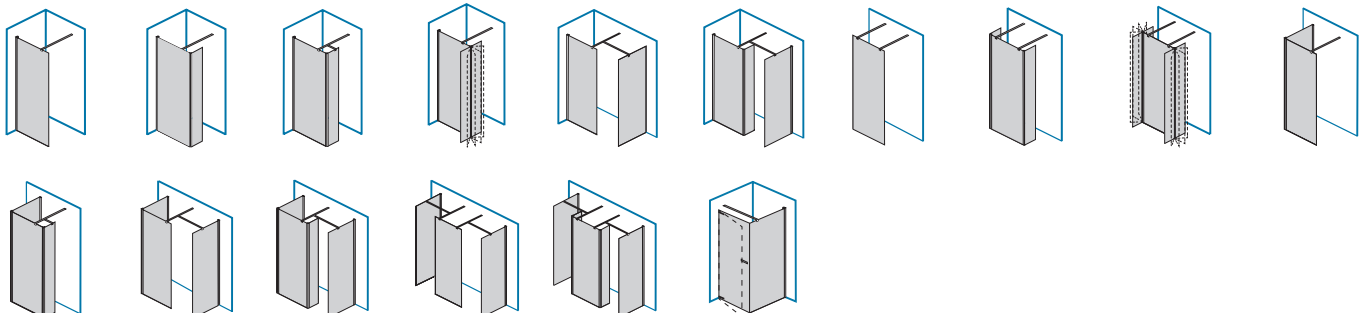

# WALK IN 8 mm

**NEW** H200 8mm **REV**

**Deflettore M 8 mm / Deflector M 8 mm / Paroi mobile M 8 mm**  
**Deflector M 8 mm / Deflector M 8 mm / Deflektor M 8 mm**

H max 217 cm  
 L min 15 cm max 60 cm



Le dimensioni sono in mm / Sizes in mm /  
 Les dimensions sont indiquées en mm /  
 Las medidas son en mm /  
 De afmetingen zijn vermeld in mm / Maßangaben in mm

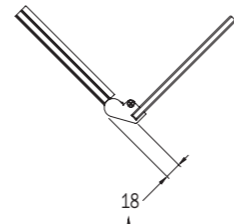
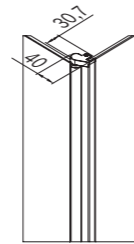
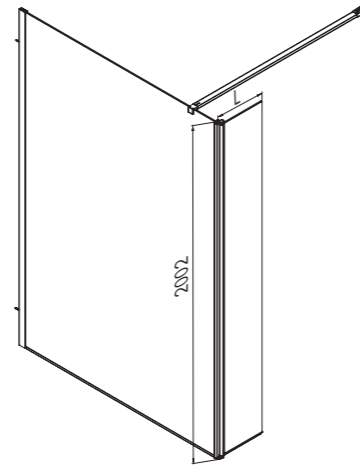

La parete A aumenta di mm 18

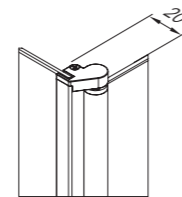

Vetro temperato di sicurezza 8 mm. Il movimento di rotazione 270° viene garantito mediante sistema Camme integrato.  
 Tempered safety glass 8 mm. The 270° round moving is guaranteed with integrated Camme-System.  
 Verre trempé de sécurité 8 mm. Le mouvement de rotation 270° est garanti grâce au système à Came intégré.  
 Vidrio templado de seguridad 8 mm. Se garantiza el movimiento de rotación 270° a través de un sistema Camme integrado.  
 Gehard zekerheidsglas 6 mm. De 270° roterende beweging wordt gegarandeerd door het geïntegreerde Camme systeem.  
 Sicherheitsglas 6 mm. Die 270° Drehung ist gewährleistet dank einer integrierten Nockenkupplung.

L	KG	
30 cm	14	1
40 cm	18	1
50 cm	22	1



Larghezza - estensibilità Breadth - extensibility Largeur - extensibilité Composición - extensibilidad Breedte - aanpassingsvermogen Breite - Anpassungsfähigkeit	cod.	cod.	cod.	cod.
<b>L 30 cm</b>	B2531 M AN 01	B2531 M AN 14	B2531 M AN 73	B2531 M AN 41
WM - BM	B2531 M ..... 01	B2531 M ..... 14	B2531 M ..... 73	B2531 M ..... 41
AC - OR - BZ	B2531 M ..... 01	B2531 M ..... 14	B2531 M ..... 73	B2531 M ..... 41
<b>L 40 cm</b>	B2532 M AN 01	B2532 M AN 14	B2532 M AN 73	B2532 M AN 41
WM - BM	B2532 M ..... 01	B2532 M ..... 14	B2532 M ..... 73	B2532 M ..... 41
AC - OR - BZ	B2532 M ..... 01	B2532 M ..... 14	B2532 M ..... 73	B2532 M ..... 41
<b>L 50 cm</b>	B2533 M AN 01	B2533 M AN 14	B2533 M AN 73	B2533 M AN 41
WM - BM	B2533 M ..... 01	B2533 M ..... 14	B2533 M ..... 73	B2533 M ..... 41
AC - OR - BZ	B2533 M ..... 01	B2533 M ..... 14	B2533 M ..... 73	B2533 M ..... 41

L'utilizzo del deflettore genera un ingombro di 18 mm da aggiungere alla dimensione della parete in abbinamento.  
 Deflector choice increases the size of the panel A by 18 mm.  
 Le choix du déflecteur augmente la dimension de la paroi A de 18 mm.  
 La elección del deflector aumenta el tamaño del panel A por 18 mm.  
 Het gebruik van de deflector genereert een overschot van 18 mm die moet worden toegevoegd aan de maat Van de wand A, Zie technische tekening.  
 Durch die Verwendung der Lenkwand wird ein zusätzliches Volumen von 18 mm erzeugt, dieses wird an das Mass der kombinierten Glasscheibe hinzugefügt.

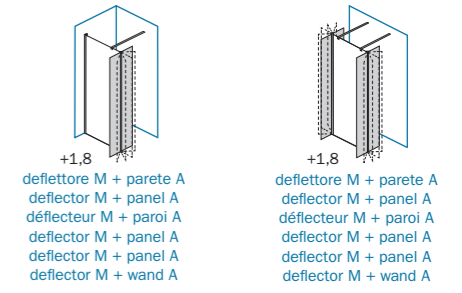

+1,8 deflettore M + parete A  
 deflector M + panel A  
 déflecteur M + paroi A  
 deflector M + panel A  
 deflector M + panel A  
 deflector M + wand A

# WALK IN 8 mm

Le dimensioni sono in mm / Sizes in mm /  
Les dimensions sont indiquées en mm /  
Las medidas son en mm /  
De afmetingen zijn vermeld in mm / Maßangaben in mm

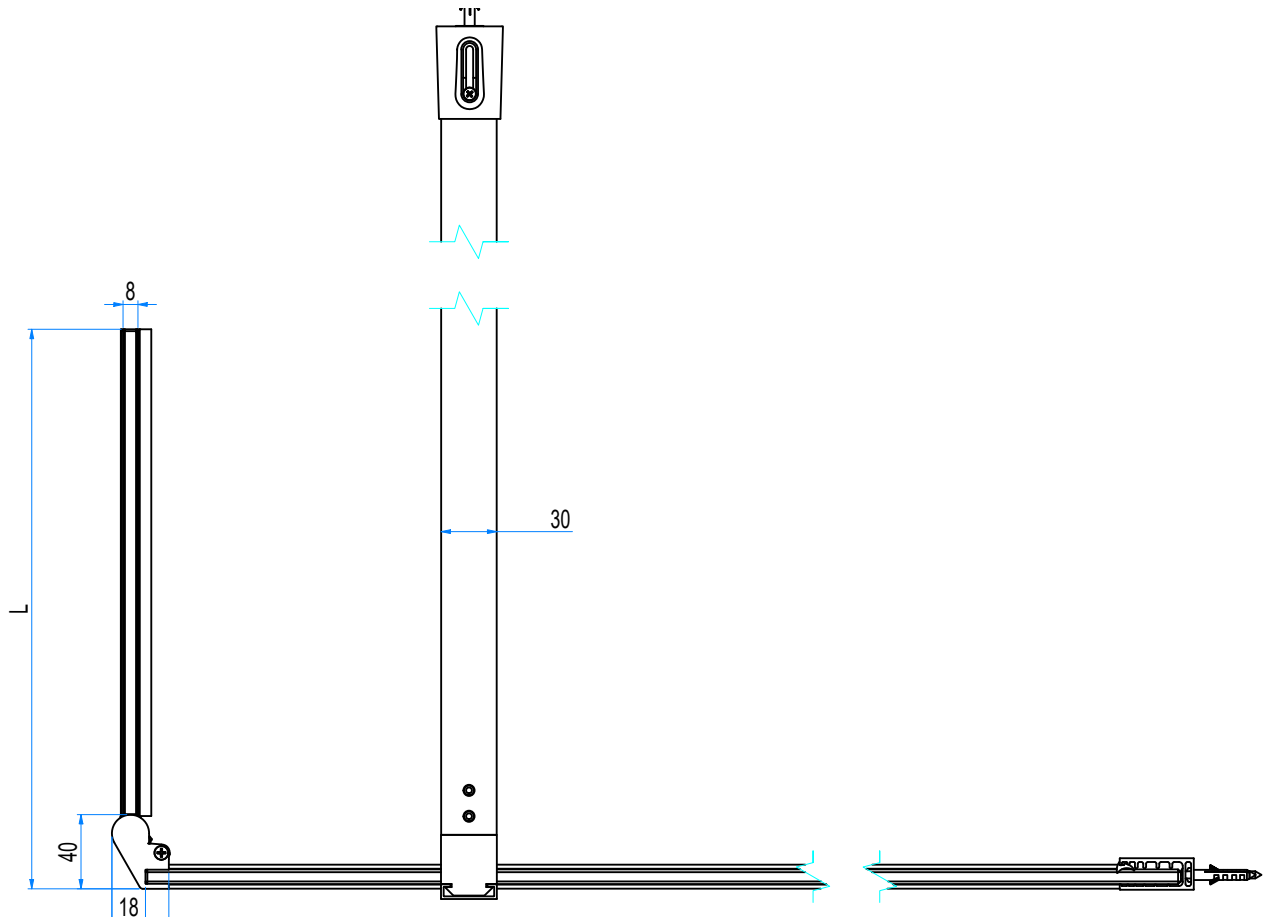

# WALK IN 6 mm



## Deflettore M 6 mm / Deflector M 6 mm Paroi mobile M 6 mm / Deflector M 6 mm Deflector M 6 mm / Deflektor M 6 mm

H max 217 cm  
L min 15 cm max 60 cm



Le dimensioni sono in mm / Sizes in mm /  
Les dimensions sont indiquées en mm /  
Las medidas son en mm /  
De afmetingen zijn vermeld in mm / Maßangaben in mm

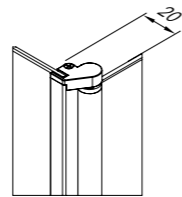
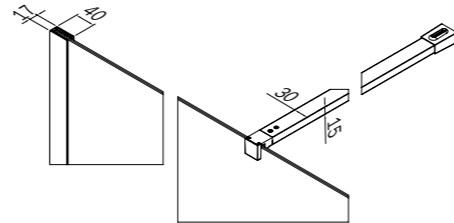
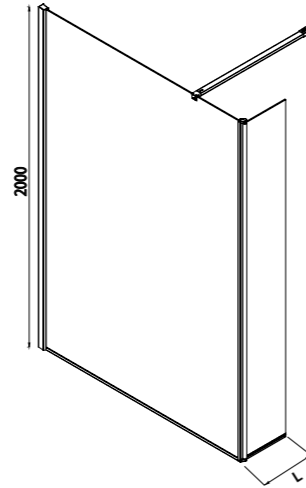

	AN	WM	BM	01	14
Larghezza - estensibilità Breadth - extensibility Largeur - extensibilité Composición - extensibilidad Breedte - aanpassingsvermogen Breite - Anpassungsfähigkeit				cod.	cod.
<b>L 30 cm</b>				B2561 M AN 01 B2561 M WM 01 B2561 M BM 01	B2561 M AN 14 B2561 M WM 14 B2561 M BM 14
<b>L 40 cm</b>				B2562 M AN 01 B2562 M WM 01 B2562 M BM 01	B2562 M AN 14 B2562 M WM 14 B2562 M BM 14
<b>L 50 cm</b>				B2563 M AN 01 B2563 M WM 01 B2563 M BM 01	B2563 M AN 14 B2563 M WM 14 B2563 M BM 14

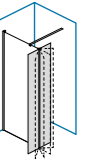

deflettore M + parete A  
deflector M + panel A  
deflettore M + paroi A  
deflector M + pared A  
deflektor + Wand A

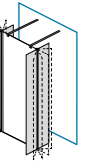

deflettore M + parete A  
deflector M + panel A  
deflettore M + paroi A  
deflector M + pared A  
deflektor + Wand A

Vetro temperato di sicurezza 6 mm.  
Il movimento di rotazione 270° viene garantito mediante sistema Camme integrato.  
Tempered safety glass 6 mm.  
The 270° round moving is guaranteed with integrated Camme-System.  
Verre trempé de sécurité 6 mm.  
Le mouvement de rotation 270° est garanti grâce au système à Came intégré.  
Vidrio templado de seguridad 6 mm.  
Se garantiza el movimiento de rotación 270° a través de un sistema Camme integrado.  
Gehard zekkerheidsglas 6 mm. De 270° roterende beweging wordt gegarandeerd door het geïntegreerde Camme systeem.  
Sicherheitsglas 6 mm. Die 270° Drehung ist gewährleistet dank einer integrierten Nockenkupplung.

L	KG	
30 cm	10	1
40 cm	11	1
50 cm	12	1

# WALK IN 6 mm

Le dimensioni sono in mm / Sizes in mm /  
Les dimensions sont indiquées en mm /  
Las medidas son en mm /  
De afmetingen zijn vermeld in mm / Maßangaben in mm

