

(GB) 36-MONTH WARRANTY: general conditions
ATTENTION: please keep a fiscal purchase document(receipt,bill,invoice etc.) together with this manual

(I) GARANZIA DI 36 MESI: condizioni generali
ATTENZIONE: conservare con questo fascicolo un documento fiscale d'acquisto(scontrino fiscale,bolla d'accompagnamento, fattura ecc.)

(F) GARANTIE DE 36 MOIS: conditions générales
ATTENTION: conserver avec ce fascicule un document officiel d'achat (remise fiscale,bordereau de livraison,facture etc.)

(D) GARANTIE VON 36 MONATEN: Allgem.Konditionen.
ACHTUNG: Mit diesem Heft bitte auch eine Quittung aufbewahren (Kassenzettel,Lieferschein,Rechnung etc.)

(NL) GARANTIE VAN 36 MAANDEN: algemene voorwaarden
OPGELET: bewaar bij dit boekje een fiscaal dokument van aankoop (kassabon,faktuur etc.)

(E) GARANTÍA DE 36 MESES: condiciones generales
ADVERTENCIA: Junto con este folleto,consérvese el justificante de compra (recibo,albaràn,factura,etc.).



- (GB) WARRANTY COD.
- (I) GARANZIA COD.
- (F) GARANTIE COD.
- (D) GARANTIE COD.
- (NL) GARANTIE COD.
- (E) GARANTIA COD.



(GB) Please follow the mounting instructions at the inside.

(I) Leggere attentamente le istruzioni all'interno.

(F) Lisez attentivement les instructions de montages à l'intérieur.

(D) Anleitungs-instruktionen sorgfältig lesen.

(NL) Goed de vermelde instructies lezen.

(E) Leer atentamente las instrucciones en el interior.

- (GB) Reversible
- (I) Reversibile
- (F) Réversible
- (D) Umkehrbar
- (NL) Omkeerbare
- (E) Reversible

B2590B
B2591B

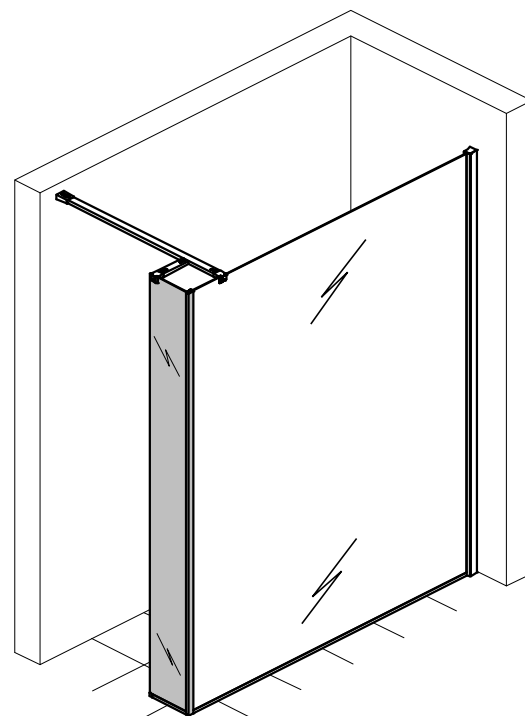
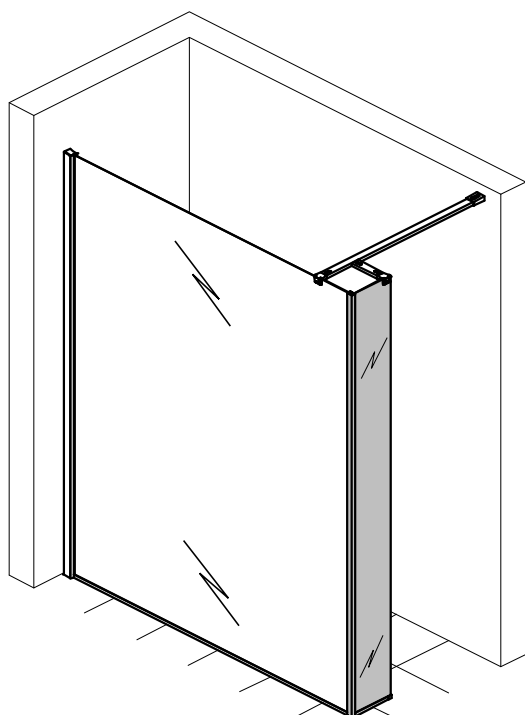

AVVERTENZE E SUGGERIMENTI PER UNA CORRETTA INSTALLAZIONE, USO E MANUTENZIONE DEL BOX DOCCIA

AVVERTENZE PRIMA DELL'INSTALLAZIONE:

- 1) Prima di procedere a qualsiasi operazione di installazione. verificare la corrispondenza del box ordinato con quello consegnato e verificare l'integrità di tutti i suoi componenti.
- 2) In particolare modo per i prodotti che hanno lastre prive di profili/telaio e assolutamente necessario mantenere le protezioni esistenti fino alla fine dell'installazione per evitare di appoggiare/sbattere le lastre determinando possibili rotture/scoppi anche successivi all'installazione.
- 3) Prima di eseguire qualsiasi operazione di foratura è necessario accertarsi che la dimensione del box corrisponda a quella del piatto.
- 4) E' necessario accertarsi che il muro non abbia un eccessivo fuori squadra. in quanto potrebbe rendere scarsa l'estensibilità del box compromettendone in certi casi la funzionalità stessa.
- 5) I box senza telaio devono essere installati sul bordo interno del piatto, per permettere l'alloggiamento del frangiflutto.
- 6) Per l'installatore: seguire attentamente le istruzioni allegate.
- 7) Nel caso di reso autorizzato. il prodotto dovrà essere re-imballato mantenendo le stesse caratteristiche di integrità che aveva nel momento della consegna.

Per qualsiasi inconveniente contattare il rivenditore.

USO E MANUTENZIONE:

- 1) Per la pulizia periodica di tutte le superfici del box doccia e in particolare per tutte le parti in alluminio e in plastica, si consiglia di usare acqua e normali detergenti liquidi delicati per la pulizia della casa con l'utilizzo di una spugna o un panno morbido, e di non usare assolutamente prodotti aggressivi, disincrostanti o abrasivi.
- 2) Per mantenere nel tempo una buona funzionalità del prodotto, è necessario periodicamente fare una manutenzione generale e in particolare regolare e lubrificare le parti in movimento.

WARNINGS AND SUGGESTIONS FOR A CORRECT SHOWER ENCLOSURE INSTALLATION, USE AND MAINTENANCE

PRECAUTIONS BEFORE INSTALLATION:

- 1) Before proceeding to any assembling operation. please verify if the delivered shower enclosure exactly corresponds to the ordered one, verifying also the complete components integrity.
- 2) In particular it is strongly recommended that for the frame-less products it is absolutely necessary to keep the existing installed protections till the end of the product assembling avoiding to lean or to knock the glass panels that could determinate possible subsequent breakage or shatters even after the final installation.
- 3) Before performing any drilling operation. please verify that the shower enclosures measures correspond to the shower tray dimensions.
- 4) It is absolutely necessary to verify the eventual wall's out of square exceeding measure. otherwise it could compromise the projected shower enclosure extensibility (not sufficient) and in some case the relative functionality.
- 5) Frameless shower enclosures have to be installed on the shower tray internal edge, to allow the breakwater gasket housing.
- 6) For the fitter: please carefully follow the enclosed instructions.
- 7) In case of authorised product return all must be exactly re-packaged maintaining the same delivery integrity characteristics.

For any inconvenient please contact the local dealer.

USE AND MAINTENANCE:

- 1) For the periodic shower enclosure cleaning surfaces and in particular the aluminium profiles and plastic components, absolutely do not use aggressive, abrasive or scale-remover products, but only use water and normal house cleaning liquid detergents with a sponge or a soft cloth.
- 2) To maintain a good shower enclosures functionality. it is necessary to periodically perform a general maintenance particularly regulating and lubricating the moving parts.

AVERTISSEMENTS ET SUGGESTIONS POUR UNE INSTALLATION, UNE UTILISATION ET UN ENTRETIEN CORRECTS DE LA PAROI DE DOUCHE

AVERTISSEMENTS AVANT INSTALLATION:

- 1) Avant de procéder à l'installation, vérifier la correspondance entre la paroi commandée et celle livrée et contrôler l'intégrité de tous ses composants.
- 2) En particulier pour les produits réalisés à partir de panneaux de verre sans profile ni cadre. il est absolument nécessaire de conserver les protections existantes jusqu'à la fin de l'installation pour éviter d'appuyer ou de frapper le verre provoquant de la sorte d'éventuels chocs ou bris de verre pouvant également intervenir une fois l'installation terminée.
- 3) Avant d'effectuer toute opération de perçage, il est nécessaire de vérifier que la dimension de la paroi corresponde à celle du receveur.
- 4) Il est nécessaire de vérifier que le mur ne présente pas un faux-aplomb exagéré, dans la mesure où cela pourrait rendre insuffisant la fourchette d'extensibilité de la paroi, compromettant dans certains cas son utilisation même.
- 5) Les parois sans cadre doivent être installées sur le bord intérieur du receveur, pour permettre le positionnement du joint brise-flux.
- 6) Pour l'installation suivre scrupuleusement les instructions de montage jointes.
- 7) En cas de retour autorisé, le produit devra être réemballé en respectant les mêmes caractéristiques d'intégrité qu'il possédait au moment de la livraison.

En cas de problème, contacter votre revendeur.

UTILISATION ET ENTRETIEN:

- 1) Pour le nettoyage périodique de toutes les surfaces de la paroi de douche et en particulier toutes les parties en aluminium et plastique, il est conseillé d'utiliser de l'eau et des détergents liquides délicats pour le nettoyage de la maison, en utilisant une éponge ou un linge souple et de ne pas utiliser de produits agressifs, désincrostant ou abrasifs.
- 2) Pour maintenir dans le temps une bonne fonctionnalité du produit, il est indispensable de procéder périodiquement à un entretien général et en particulier régler et lubrifier les parties en mouvement.

RATSCHLAGE FÜR EINE KORREKTE MONTAGE UND PFLEGE DER DUSCHKABINEN

HINWEISE VOR DER MONTAGE:

- 1) Überzeugen Sie sich vor der Montage:
Überprüfen den von Ihnen bestellten Artikel mit den gelieferten.
Überprüfen die Integrität der einzelnen Komponenten
- 2) Bei rahmenlosen Produkten ist unbedingt die Kunststoffschutz bis am Ende der Montage auf den Scheiben zu lassen. Diese Maßnahme vermeidet mögliche Glasbrüche.
- 3) Bevor Sie die Löcher in die Mauer bohren, überprüfen Sie ob die Duschtrennung und die Duschwanne übereinstimmen.
- 4) Die Mauer sollte nicht mehr als 1,5 cm außer Lot sein.
- 5) Rahmenlose Duschkabinen müssen mit Anschlag der Innenkante von der Duschwanne montiert werden um somit den Schwelleiste zu montieren.
- 6) Bei Installation der Duschtrennung folgen die Montageanleitungen.
- 7) Bei berechtigter Rücksendungen. muß die Duschtrennung in der selbe Verpackungsart wie von dem Hersteller geschickt war, verpackt sein.

Bei eventuelle Schwierigkeiten, mit dem Fachhandel in Verbindung setzen.

GEBRAUCH UND PFLEGE:

- 1) Für die periodische Reinigung aller Duschtrennung Oberfläche, besonders für die Kunststoff und Aluminium Teilen, ratet man nur Wasser und leichte Washmitteln mit Schwamm benutzen. Kein aggressive, abschleifende oder entzündende Waschmittel benutzen.
- 2) Um eine gute und lange Betrieb des Produktes zu gewähren ist nötig eine periodische allgemeine Pflege und auch die Schmierung der Schiebenelemente.

ADVERTENCIAS Y SUGERENCIAS PARA UN CORRECTO MONTAJE, USO Y MANTENIMIENTO DE LA MAMPARA DE DUCHA

SUGERENCIAS PREVIA INSTALACION:

- 1) Antes de proceder a la instalacion de la mampara, verificar que el producto entregado corresponda exatamente al pedido y tambien se tendra que verificar la integridad de los accesorios.
- 2) En modo especifico para todos aquellos articulos que no lleven perfiles se tendran que mantenerlas protecciones para no permitir daños a las partes mas sensibles mampara antes de instalarla, en este modo se evitara una conservacion perfecta del producto antes de ser montada.
- 3) Antes de taladrar la pared es necesario controlar que las medidas del plato de ducha correspondan a la mampara pedida.
- 4) Seria necesario controlar que la pared donde se montara la mampara no tuviera una excisivua fuera de escuadra en ese caso podria resultar insuficiente la extensibilidad y comprometer las funciones de la mampara.
- 5) Las mamparas si perfiles tienen que ser montadas en el borde interior del plato ducha para permitir la instalacion del vierteaguas.
- 6) Para su instalacion seguir las siguientes instrucciones.
- 7) En caso de devoluciones autorizadas, el producto tendra que ser puesto en su embalaje y tendra que conservar integridad y características originales.

Para cualquier informacion consultar el distribuidor.

USO E MANTENIMIENTO:

- 1) Para la limpieza periodica de nuestra mamparas y en particular las partes en aluminio y rodamientos e en material plastico, se aconseja de usar normales detergentes líquidos y delicados para la limpieza de la casa, utilizando un trapo o un paño, es aconsejable no usar en nign caso productos agresivos.
- 2) Para mantener una buena funcionabilidad del producto es necesario periodicamente hacer un mantenimiento.

AVISOS E SUGESTÕE PARA A CORRECTA INSTALAÇÃO, USO E MANUTENÇÃO DE CABINES

PRECAUÇÕES ANTES DA INSTALAÇÃO:

- 1) Antes de proceder a qualquer operação de instalação, por favor verificar se a cabine entregue corresponde exactamente à pretendida, verificando também o estado completo de todos os componentes.
- 2) É fortemente recomendado que para os artigos sem moldura, é absolutamente necessário manter os invólucros de protecção existentes até ter terminado a instalação do produto, evitando choques nos painéis de vidro, que podem determinar consequentemente possíveis quebras ou riscos mesmo após a montagem final.
- 3) Antes de proceder a qualquer tipo de perfuração, por favor verificar que as medidas da cabine correspondem às dimensões da base de chuveiro.
- 4) É absolutamente necessário verificar se existem paredes fora de esquadria excedendo as medidas, uma vez que esta situação pode comprometer a extensibilidade da cabine (não sendo suficiente) e em alguns casos a sua funcionalidade.
- 5) Cabines sem moldura metálica devem ser instaladas na parte interior da base de chuveiro, permitindo uma correcta instalação do perfil vedante.
- 6) Para o ajustador: por favor siga cuidadosamente as instruções anexas.
- 7) Em caso de autorização de devolução, o material deverá estar devidamente embalado mantendo as mesmas características e integridade da entrega.

Para qualquer situação inconveniente, contactar o revendedor local.

USO E MANUTENÇÃO:

- 1) Para a limpeza periódica das superfícies da cabine, e em particular os perfis de alumínio e componentes plásticos, não utilizar absolutamente qualquer tipo de detergente abrasivo, agressivo ou anti-calcário, mas apenas água e detergente líquido normal de limpezas domésticas com uma esponja ou pano macio.
- 2) Para manter uma correcta funcionalidade da cabine, é necessário proceder a uma manutenção geral periódica, regulando e lubrificando as partes móveis.

ΠΡΟΕΙΔΟΠΟΙΗΣΕΙΣ ΚΑΙ ΠΡΟΤΑΣΕΙΣ ΓΙΑ ΜΙΑ ΣΩΣΤΗ ΤΟΠΟΘΕΤΗΣΗ (ΕΓΚΑΤΑΣΤΑΣΗ) ΓΙΑ ΤΙΣ ΝΤΟΥΣΙΕΡΕΣ-ΧΡΗΣΗ ΚΑΙ ΣΥΝΤΗΡΗΣΗ

ΠΡΟΦΥΛΑΞΕ΄Σ ΠΡΙΝ ΤΗΝ ΕΓΚΑΤΑΣΤΑΣΗ:

- 1) Πριν προχωρήσετε σε οποιαδήποτε συνλρμολογήση θα πρέπει πρώτα να ελεγγετε αν το προϊόν που εχετε παραλαβει αντιστοιχει σε αυτο που αρχικα ειχατε παραγγειλει, καθως επισης και αν το παραλαβατε σε αριστη κατασταση.
- 2) Ειδικότερα, σοβαρα συνισταται η προσοχη για τα πλαίσια (frameless) και είναι απαραίτητο να διατηρουν την αρχική τους συσκευασία εως το τελος της συναρμολογήσης, αποφευγοντας τα χτυπηματλ - γρατσουνισματα του κρυσταλαου, τα οποια μπορεί να προκληθουν ακομα και μετα την τελική τοποθετηση.
- 3) Πριν εκτελεσετε οποιαδήποτε λειτουργια, ελεγγετε οτι υπαρχει η σωστη αντιστοιχια (σωστη αντιστ. στα μετρα) μεταξύ του προϊόντος και της ντουσιερας.
- 4) Τα πλαίσια χωρις προφιλ πρέπει να τοποθετουνται στην ντουσιερα στην εσωτερική ακρη ετσι ωστε να επιτρεπεται και η τοποθετηση του εξωτερικού προφιλ (προαιρετικά).
- 5) Για την προσαρμογή: παρακαλουμε οπως ακολουθηθουν πιστλ οι εσωκλειστες οδηγιες.
- 6) Στερεπωση που ενα προιον πρέπει να επιστραφει, σημιζωσατε οτι θα πρέπει να διατηρει την αρχικη του συσκευασία (να συσκευαστει οπως κατα την παραλαβη του)

Για οποιαδήποτε περαιτερω διευκρινιση, παρακασουμε οπως επικοινωνησετε με τον εμπορο της περιοχης σας.

ΧΡΗΣΗ ΚΑΙ ΣΥΝΤΗΡΗΣΗ:

- 1) Για τον καθαρισμο και ειδικότερα των επιφανειων αλουμινιου και πλαστικων μερων, δεν επιτρεπεται η χρηση “σκαηρων” καθαριστικων/η λειαντικων, αλλα ο καθαρισμος θα πρέπει να γινεται με ενα κοινο καθαριστικο (υγρο) με τη βοηθεια ενος σφουγγαριου/η ενος κομματιου μαλακου υφασματος.

ΠΡΕΔΥΠΡΕΨΗΝΗ ΚΑΙ ΙΝΣΤΡΥΚΤΙΟΝ ΠΟ ΠΡΑΨΙΛΗΝ ΟΥΣΤΒΝΟΨΚΕ, ΕΨΠΛΥΑΤΑΤΙΟΝ ΚΑΙ ΤΕΧΝΙΕΣΚΟΜΟ ΟΨΛΥΨΙΒΑΝΙΟΝ ΔΥΣΗΨΟΨ ΚΑΒΙΝΗ

ΠΕΡΕΔ ΟΥΣΑΝΟΨΚΟΨ:

- 1) ΠΕΡΕΔ ΟΥΣΑΝΟΨΚΟΨ ΠΡΨΨΕΡΕΤΗ ΣΟΨΨΕΤΨΙΨ ΕΚΑΨΥ ΠΟΛΥΨΕΝΗ ΔΥΣΗΨΟΨ ΚΑΒΙΝΗ ΚΑΙ ΕΨΟΛΥΣΤΗΝ ΟΥΣΕΣ ΚΟΨΠΟΝΕΝΤΨ.
- 2) Β ΟΨΟΨΥΣ ΣΛΥΨΑΨΥ, ΚΟΨΔΑ Υ ΤΨΨΑΡΑ ΕΨΤΕ ΣΤΕΚΛΑ ΒΕΖ ΠΡΟΨΙΛΕΨ/ΚΑΡΚΑΣΑ ΑΒΣΟΛΥΤΟΝ ΝΕΟΨΧΑΡΙΤΟ ΣΟΨΡΑΝΗΨ ΣΥΣΤΕΨΥΨΟΨΥ ΖΑΠΛΑΤΥ ΔΟ ΚΟΝΤΑ ΟΥΣΑΝΟΨΚΟΨ, ΤΨΨΟΨ ΙΖΒΕΨΑΤΕ ΒΟΖΜΟΨΝΗΣ ΠΨΨΕΨΔΕΝΙΨ Β ΠΡΟΨΕΣΣΕ ΟΥΣΑΝΟΨΚΟΨ.
- 3) ΠΕΡΕΔ ΤΕΜ ΚΑΚ ΠΡΨΣΤΥΠΙΤΕ Κ ΚΑΚΟΨ-ΛΙΒΟ ΟΠΕΡΑΤΙΟΝ ΠΟ ΣΨΕΡΛΕΝΙΟΝ ΝΕΟΨΧΑΡΙΤΟ ΒΕΨΕΨΙΨΕΨ, ΤΨΟ ΡΑΖΕΡ Μ ΚΑΒΙΝΗ ΣΟΨΨΨΤΨΥΨΕΨ ΡΑΖΕΡΟ ΠΟΔΔΟΝΑ.
- 4) ΝΕΟΨΧΑΡΙΤΟ ΒΕΨΔΕΝΤΗΨ ΤΑΚΨΕ, ΤΨΟ ΥΓΟΛ ΝΑΚΛΟΝΑ ΣΤΕΝΗ ΝΕ ΝΑΜΟΝΟ ΟΤΛΙΕΑΤΕΣ ΟΤ 90°, ΤΑΚ ΚΑΤ ΟΤΟ ΒΛΙΕΤΗ ΝΑ ΡΑΣΨΙΡΥΑΕΨΟΨΤΗ ΚΑΒΙΝΗ ΚΑΙ Β ΝΕΚΟΤΨΡΥΣ ΣΛΥΨΑΨΥ ΟΤΟ ΜΟΨΕΤ ΠΨΛΙΕΨΤΗ ΝΑ ΕΕ ΦΥΝΚΤΙΟΝΙΨΡΟΒΑΝΙΟΝ.
- 5) ΚΑΒΙΝΗ ΒΕΖ ΚΑΡΚΑΣΑ ΔΟΛΨΝΤΕ ΒΥΤΗ ΟΥΣΑΝΟΨΚΕΝΕΤΗ ΝΑ ΒΝΥΤΡΕΝΝΗ ΚΡΑΨ ΠΟΔΔΟΝΑ ΔΡΥΑ ΡΑΖΜΕΨΕΝΙΑ ΒΟΠΝΟΡΕΖΑ.
- 6) ΔΡΥΑ ΜΑΣΤΕΡΑ ΠΟ ΟΥΣΑΝΟΨΚΕ: ΒΝΙΜΑΤΕΡΟΝ ΣΛΕΔΟΨΑΤΕ ΠΡΙΟΛΥΨΕΝΝΗ ΙΝΣΤΡΥΚΤΙΟΝ.
- 7) Β ΣΛΥΨΑΕ ΑΥΤΟΡΙΖΟΨΒΑΝΟΨΝΟ ΒΟΖΨΡΑΤΑ, ΤΨΨΑΡ ΒΟΛΨΕΝ ΒΥΤΗ ΒΝΨΥ ΟΥΨΑΚΟΨΒΑΝ ΚΑΙ ΙΜΕΤ ΤΟΤ ΨΕ ΒΙΔ ΚΑΙ ΧΑΡΑΚΤΕΡΙΣΤΨΥΑΚΙ, ΤΨΟ ΚΑΙ ΝΑ ΜΟΜΕΝΤ ΠΤΨΟΨΑΨΚΙ.

Πρι λυοϑυς ζατρυδνενηαυ οβρατσηαυ κ ποσασυκυ’.

ΕΨΠΛΥΑΤΑΤΙΟΝ ΚΑΙ ΤΕΧΝΙΕΣΚΟΜΟ ΟΨΛΥΨΙΒΑΝΙΟΝ:

- 1) ΔΡΥΑ ΠΕΡΙΟΔΙΕΣΚΟΨ ΟΨΚΙΣΤΗ ΚΑΒΙΝΗ ΔΥΣΗΨΟΨ ΚΑΒΙΝΗ ΚΑΙ ΟΨΟΒΕΝΟ ΕΕ ΑΠΟΜΙΝΙΕΨΨΛ ΚΑΙ ΝΛΑΣΚΙΚΟΨΥΣ ΔΕΤΑΛΕΨ, ΣΟΨΕΤΥΕΜ ΙΣΠΟΛΥΨΕΡΕΤΗ ΒΟΔΥ Σ ΔΟΒΑΨΛΕΝΙΟΜΟ ΜΥΑΚΗΣ ΧΟΖΥΑΨΤΒΕΝΝΗΣ ΜΟΨΟΨΥΣ ΣΡΕΔΥΣΤΑ ΚΑΙ ΙΣΠΟΛΥΨΕΡΕΤΗ ΓΥΒΚΥ ΟΛΙ ΜΥΑΚΥΟ ΤΚΑΝΗ. ΝΕ ΙΣΠΟΛΥΨΕΡΕΤΗ ΑΓΡΕΣΙΨΒΕΝΝΗΣ ΚΙΣΤΑΨΙΕΣ ΚΑΙ ΑΒΡΑΨΙΒΕΝΝΗΣ ΣΡΕΔΥΣΤΑ, ΣΡΕΔΥΣΤΑ ΠΡΟΤΙΨ ΒΟΡΑΨΟΒΑΝΙΑ ΝΑΚΙΠΗ.
- 2) ΔΡΥΑ ΠΡΟΔΟΛΨΙΤΕΡΗ ΚΑΙ ΧΟΡΟΨΕΡ ΗΡΟΨΤΗ ΟΒΟΡΥΔΟΒΑΝΙΑ, ΝΕΟΨΧΑΡΙΤΟ ΠΕΡΙΟΔΙΕΣΚΟΨ ΠΡΟΨΔΕΡΕΤΗ ΟΒΣΥΗ ΤΕΧΝΙΕΣΚΟΨ ΟΣΜΟΤΡ Ν Β ΟΨΟΒΕΝΝΟΤΗ ΡΕΓΥΛΙΨΡΟΒΑΤΕ ΚΑΙ ΣΜΑΖΥΨΕΡΕΤΗ ΠΟΔΥΨΙΒΕΝΝΗ ΚΑΨΤΗ.

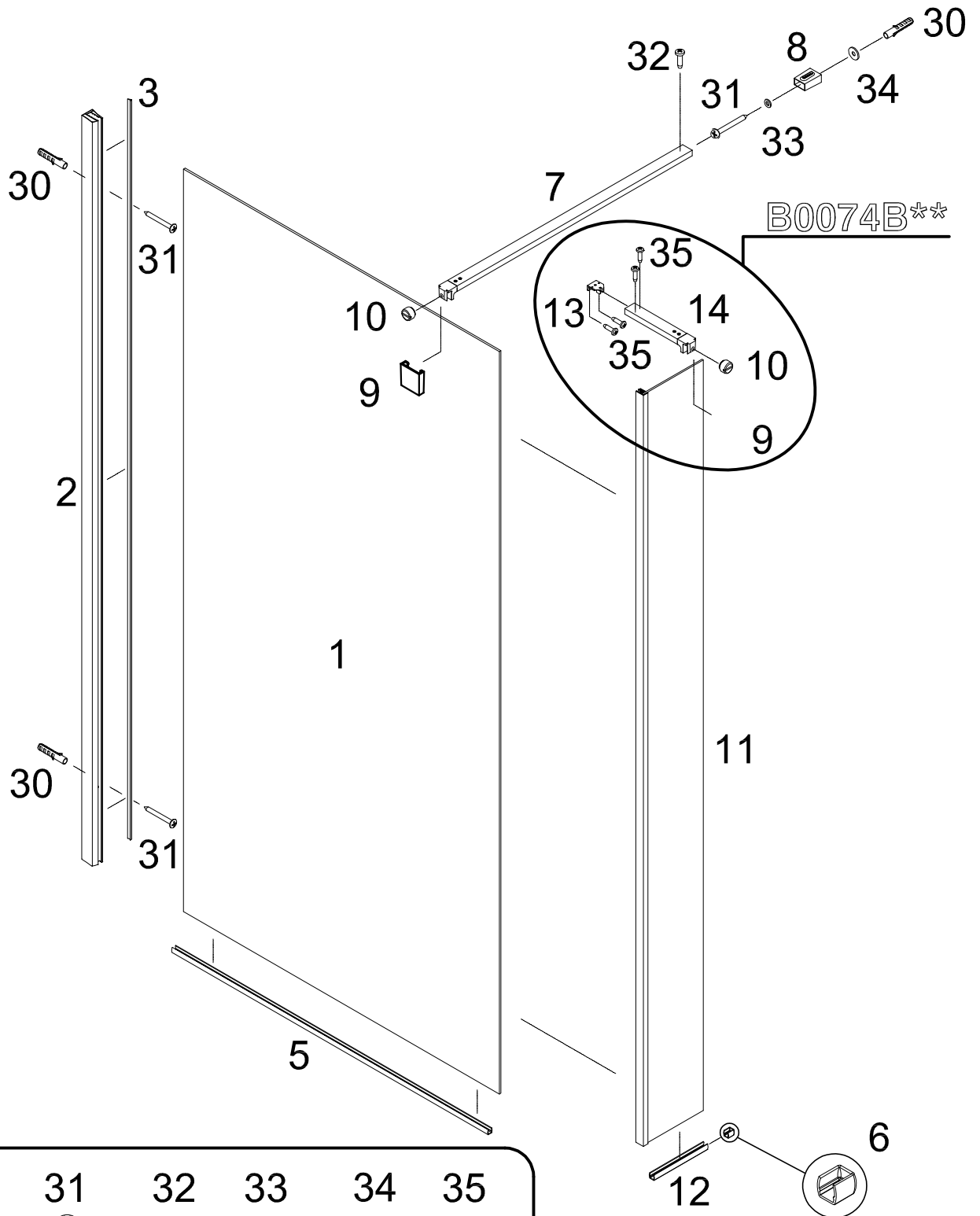

30	31	32	33	34	35
N° 3 ∅ 6 X 30	N° 3 ∅ 4,2 X 32	N° 1 ∅ 3,5 X 13	N° 1	N° 1	N° 4 ∅ 3,5 X 13

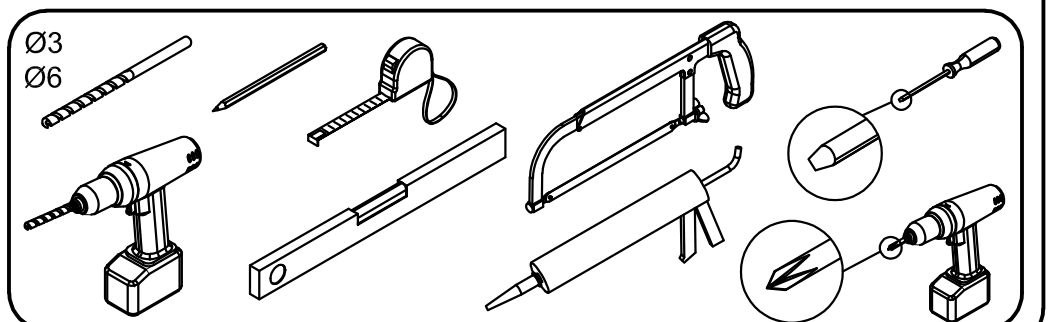
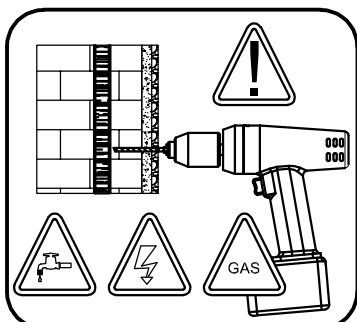

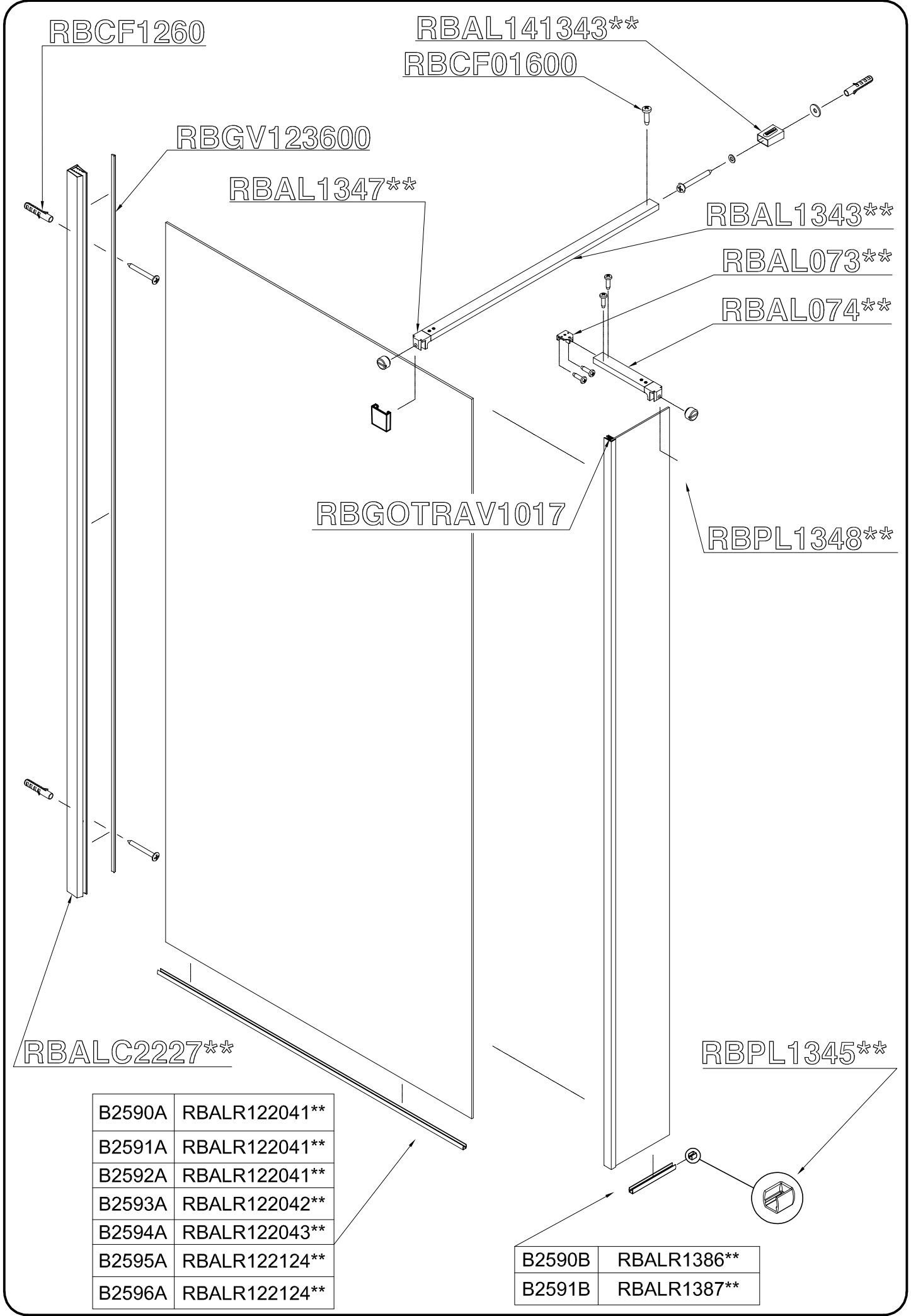

RBCF1260

RBAL141343**
RBCF01600

RBGV123600

RBAL1347**

RBAL1343**

RBAL073**

RBAL074**

RBGOTRAV1017

RBPL1348**

RBALC2227**

RBPL1345**

B2590A	RBALR122041**
B2591A	RBALR122041**
B2592A	RBALR122041**
B2593A	RBALR122042**
B2594A	RBALR122043**
B2595A	RBALR122124**
B2596A	RBALR122124**

B2590B	RBALR1386**
B2591B	RBALR1387**

RBAL1343**

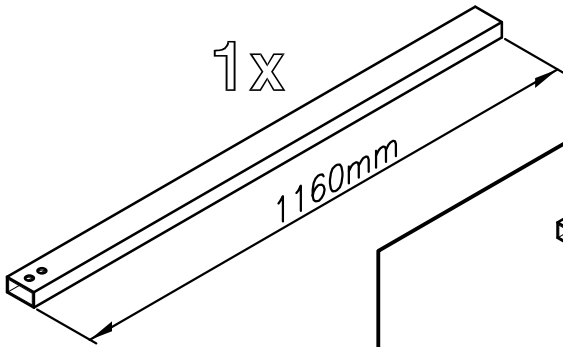

RBAL074**

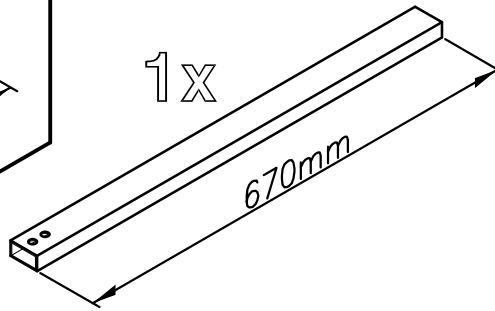

RBAL073**

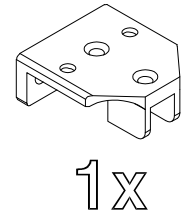

RBALC2227**

1x

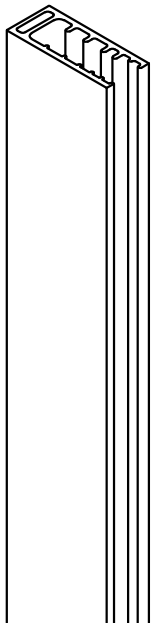

RBCF01600

1x



ø5

1x



ø14

1x



ø6x30

1x



ø4,2x32

1x



ø3,5x13

RBAL141343**

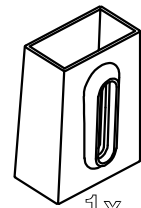

1x



ø3,5x13

1x

RBGOTRAV1017

1x

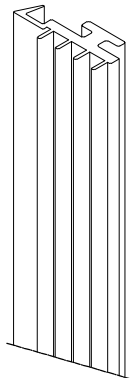

RBAL1347**

1x

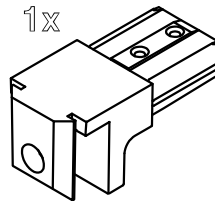

2x



N°2
ø3,5x13

1x



N°1
ø10x7

RBPL1348**

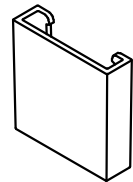

RBCF1260

3x



ø6x30

3x

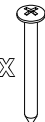

ø4,2x32

RBGV123600

1x

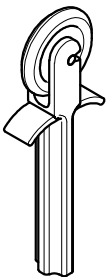

1x

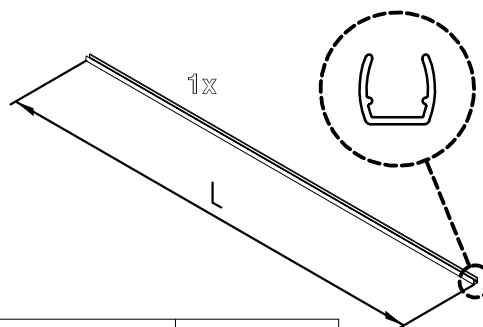
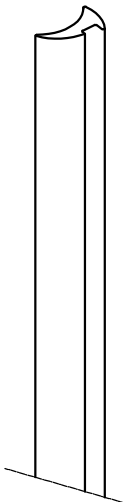

B2590B	RBALR1386AN	L = 165 mm
B2591B	RBALR1387AN	L = 265 mm
B2590A	RBALR122041AN	L = 945 mm
B2591A	RBALR122041AN	L = 945 mm
B2592A	RBALR122041AN	L = 945 mm
B2593A	RBALR122042AN	L = 1145 mm
B2594A	RBALR122043AN	L = 1345 mm
B2595A	RBALR122124AN	L = 1745 mm
B2596A	RBALR122124AN	L = 1745 mm

RBPL1345**

1x

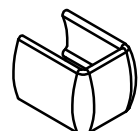

1

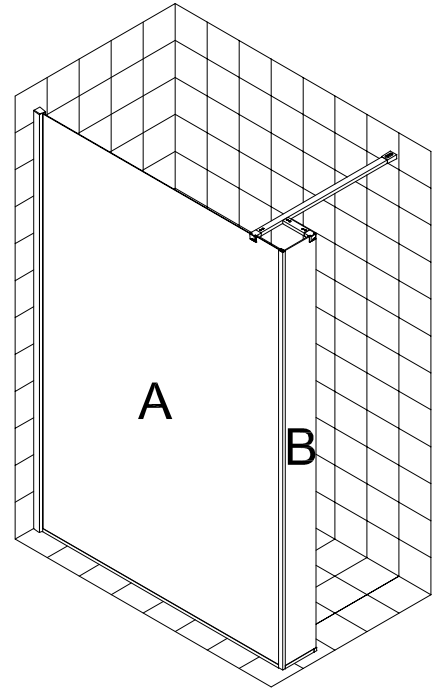
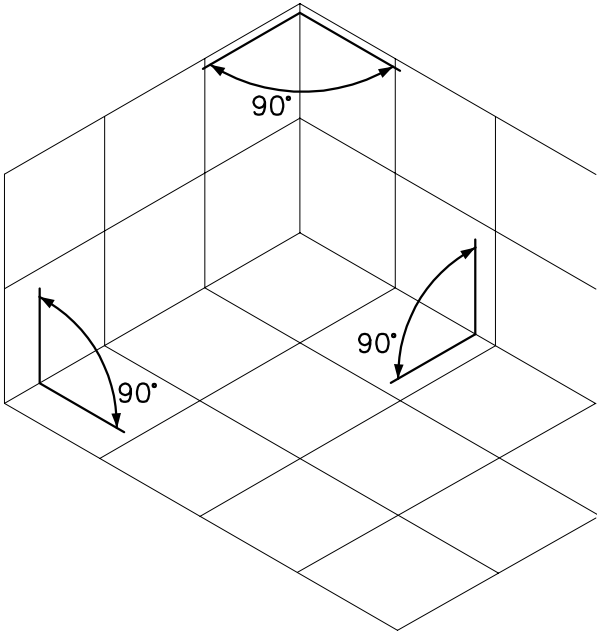

B2590A

B2591A

B2592A

B2593A

B2594A

B2595A

B2596A

B2590B

B2591B

2

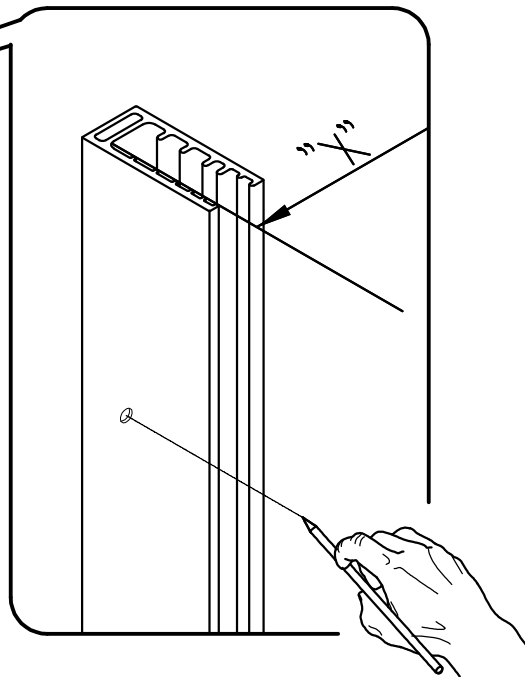
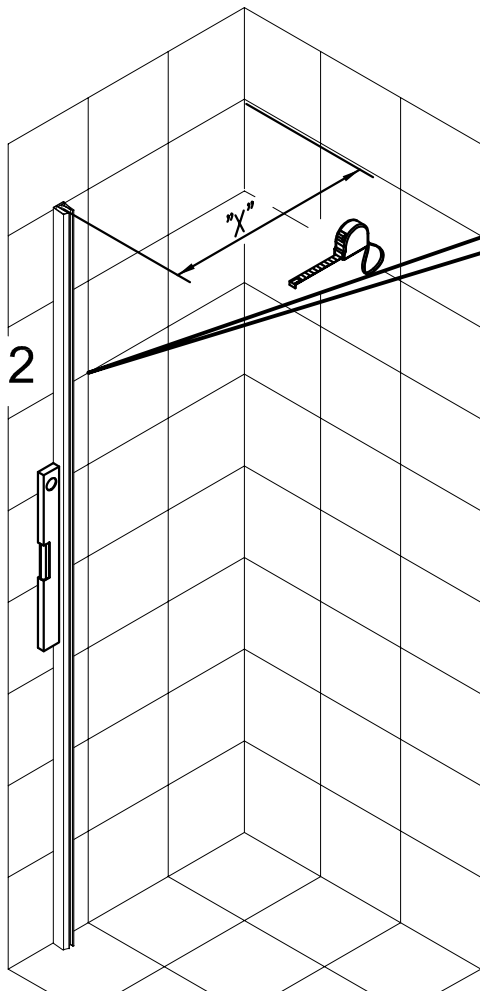

"X" max = 1200 mm

3

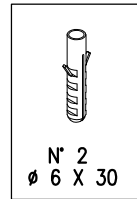
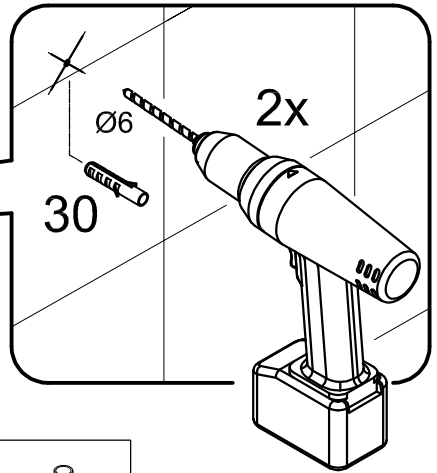
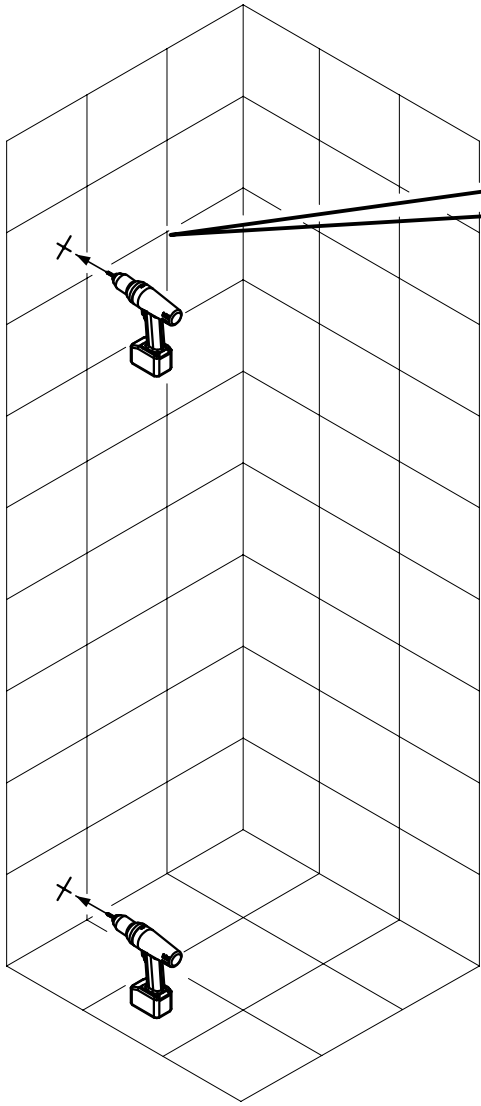

4

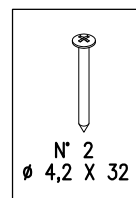
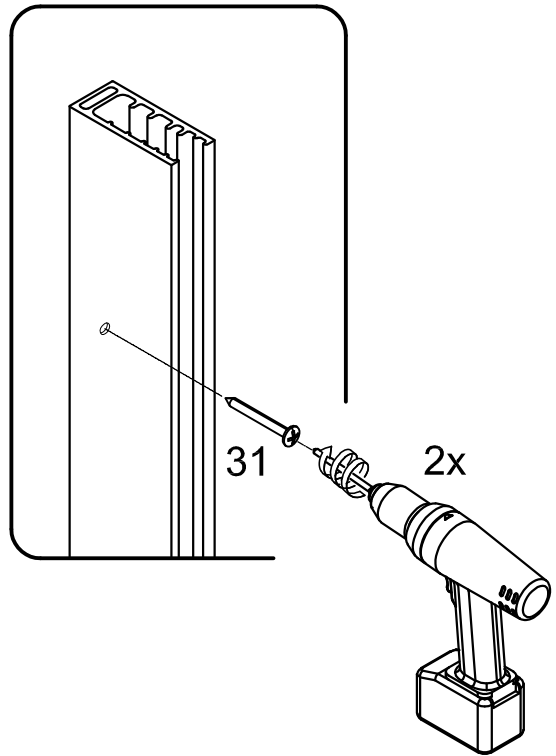
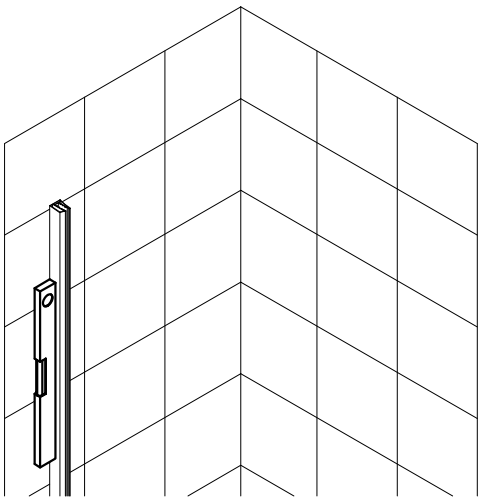

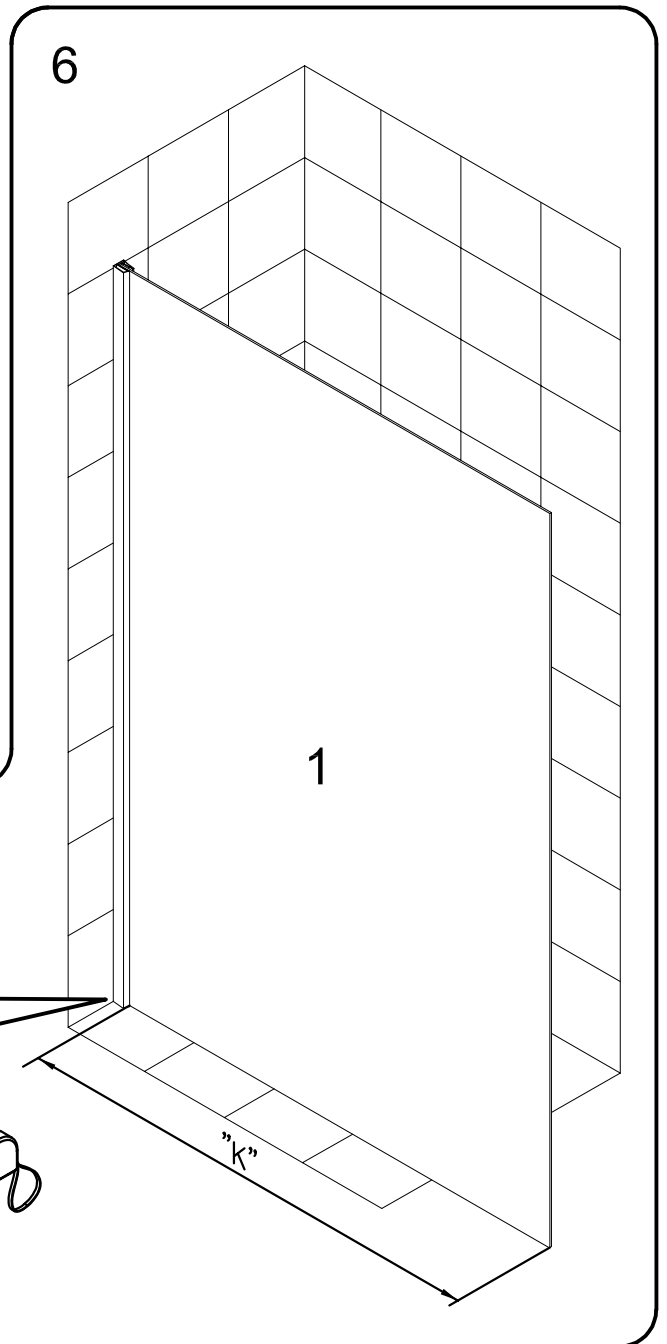
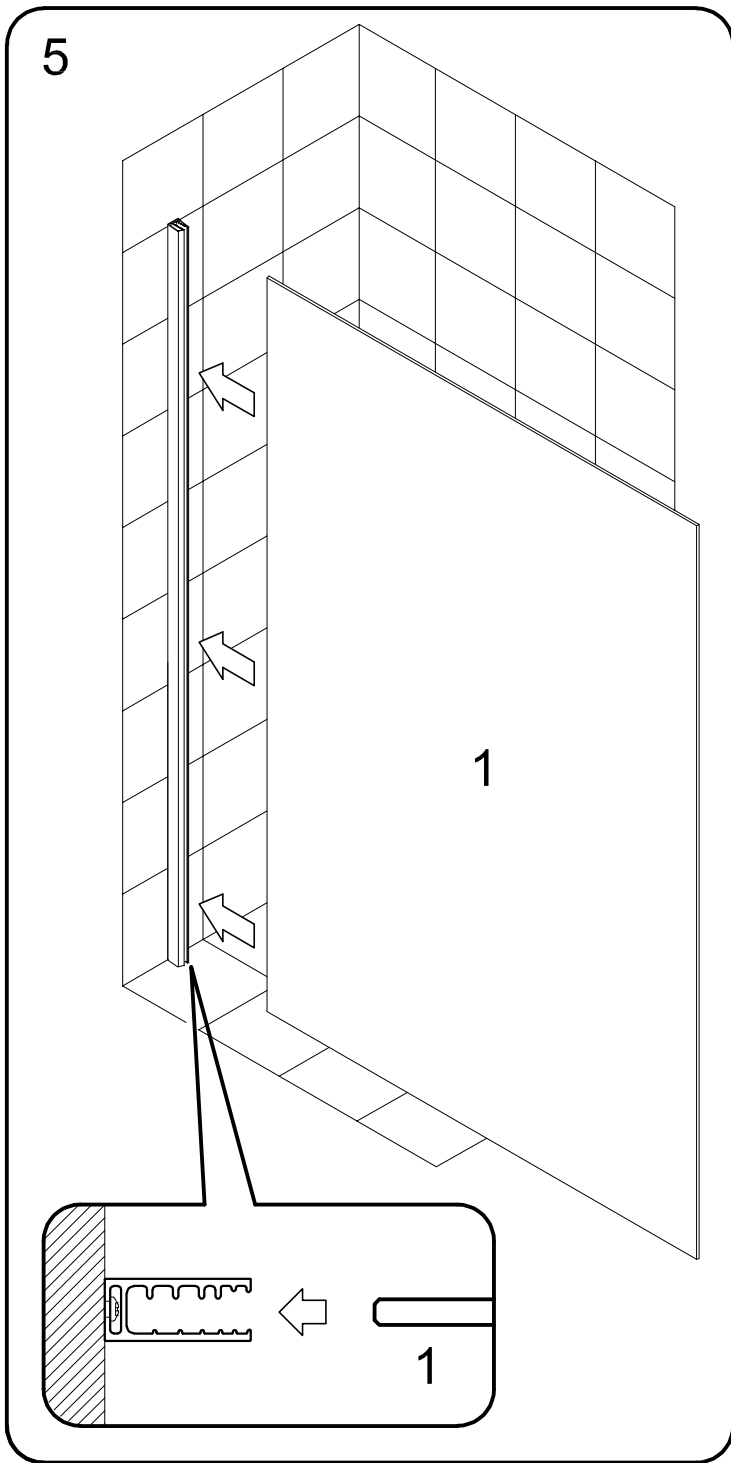

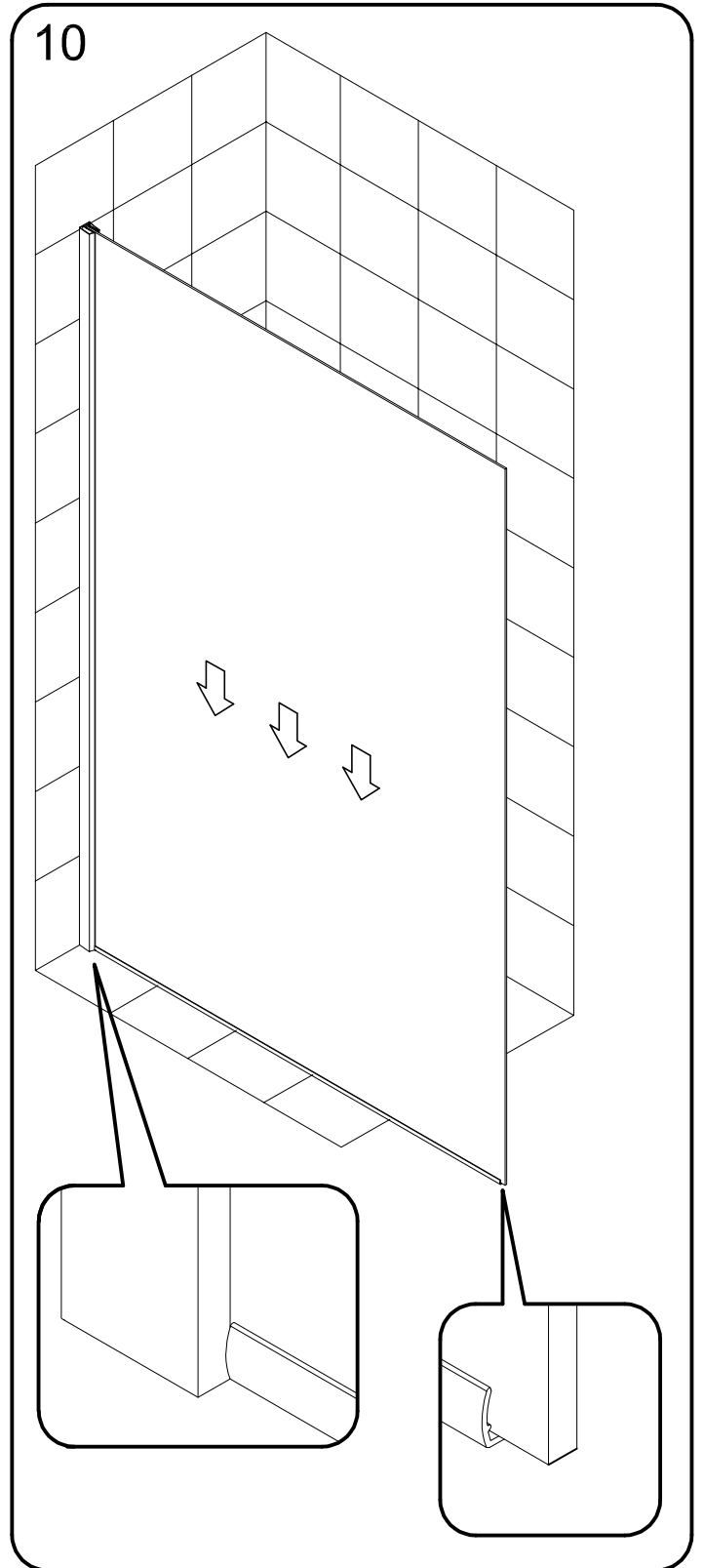
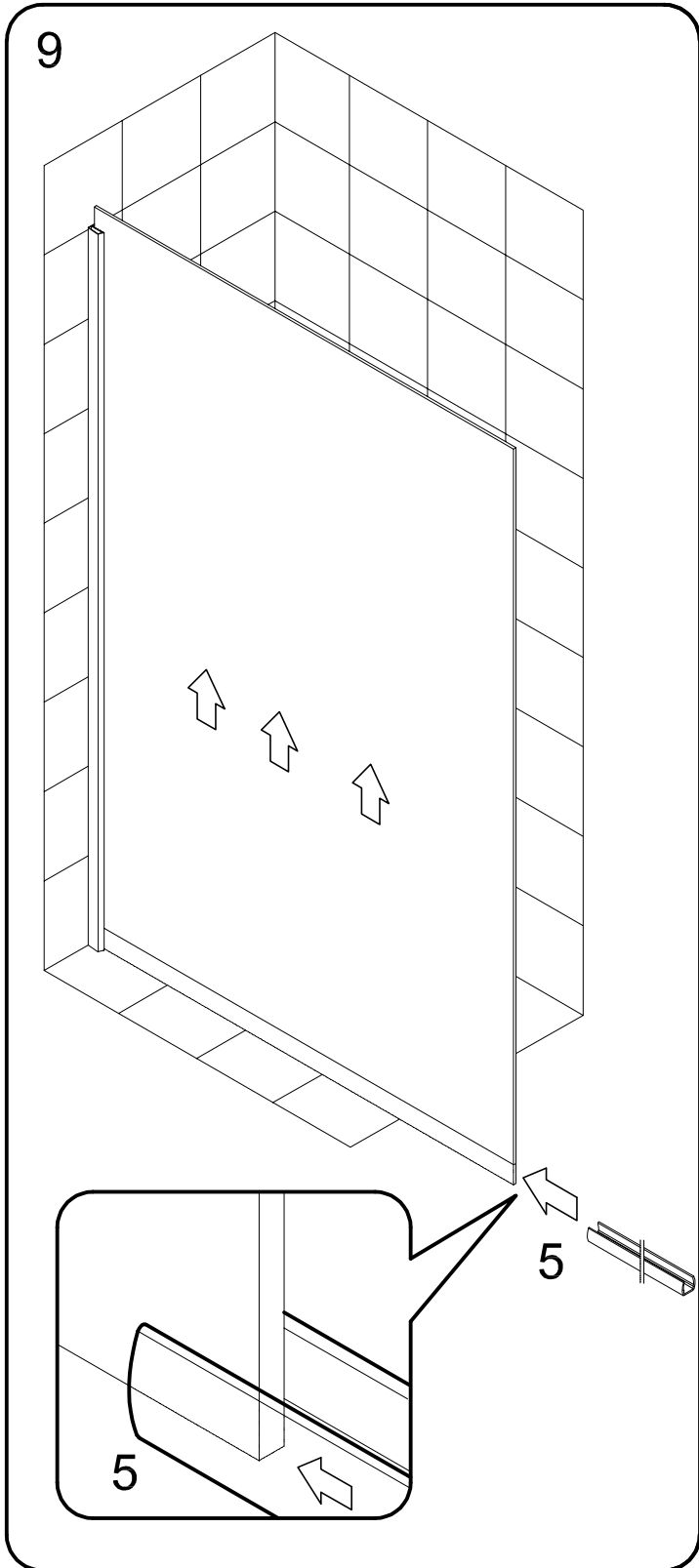
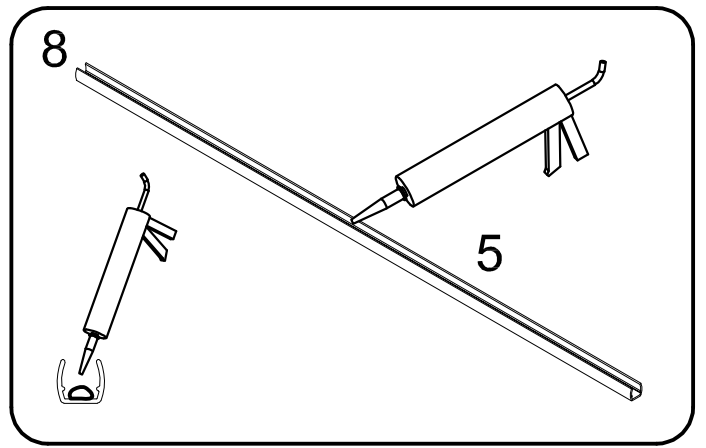
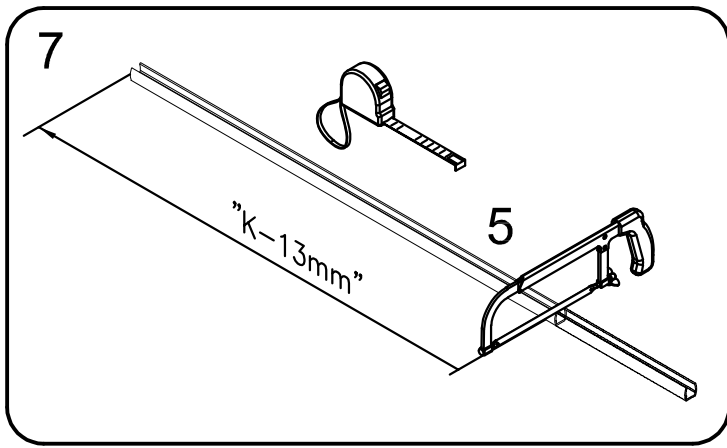

11

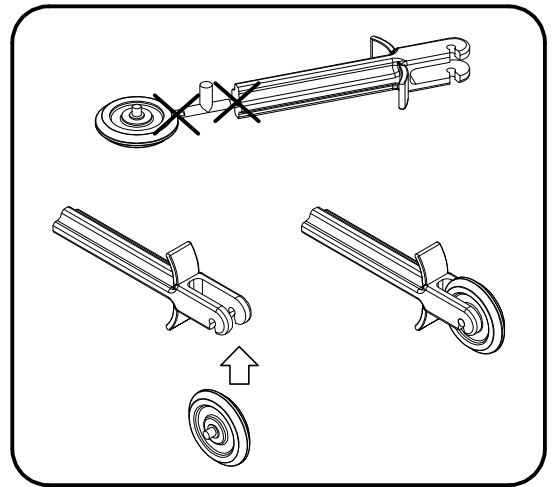
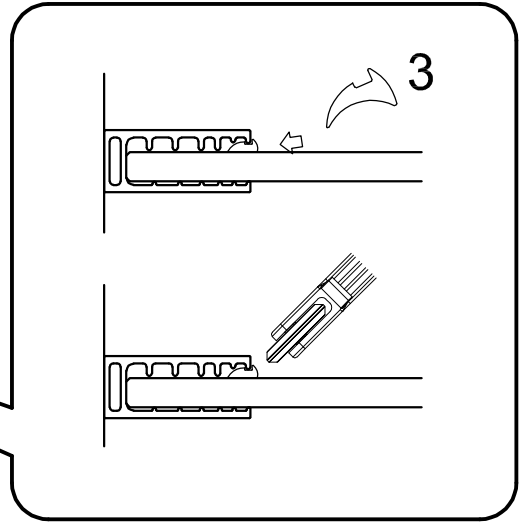
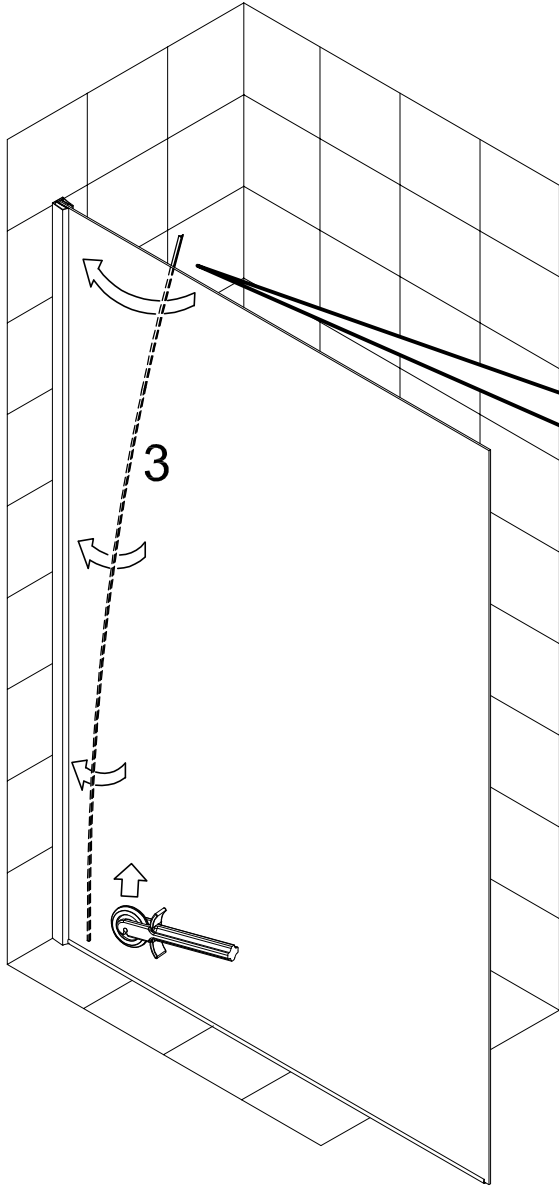

12

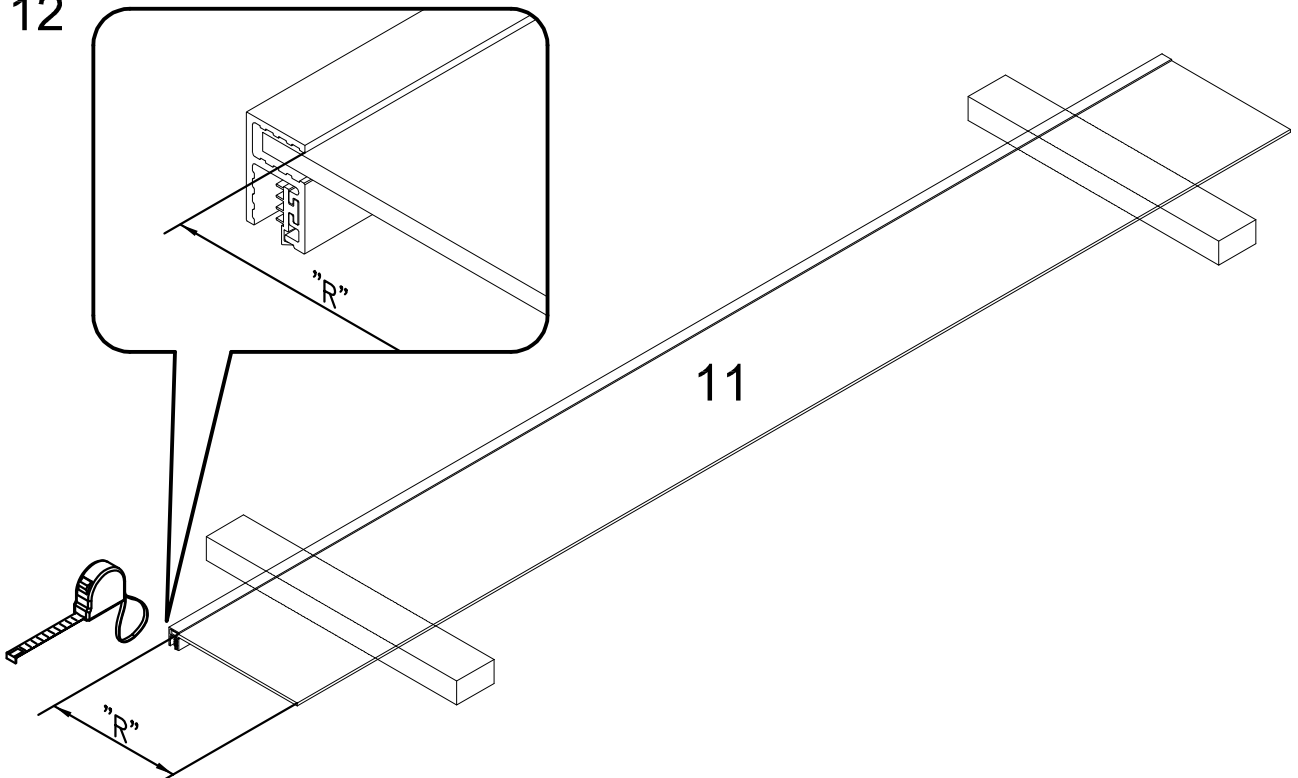

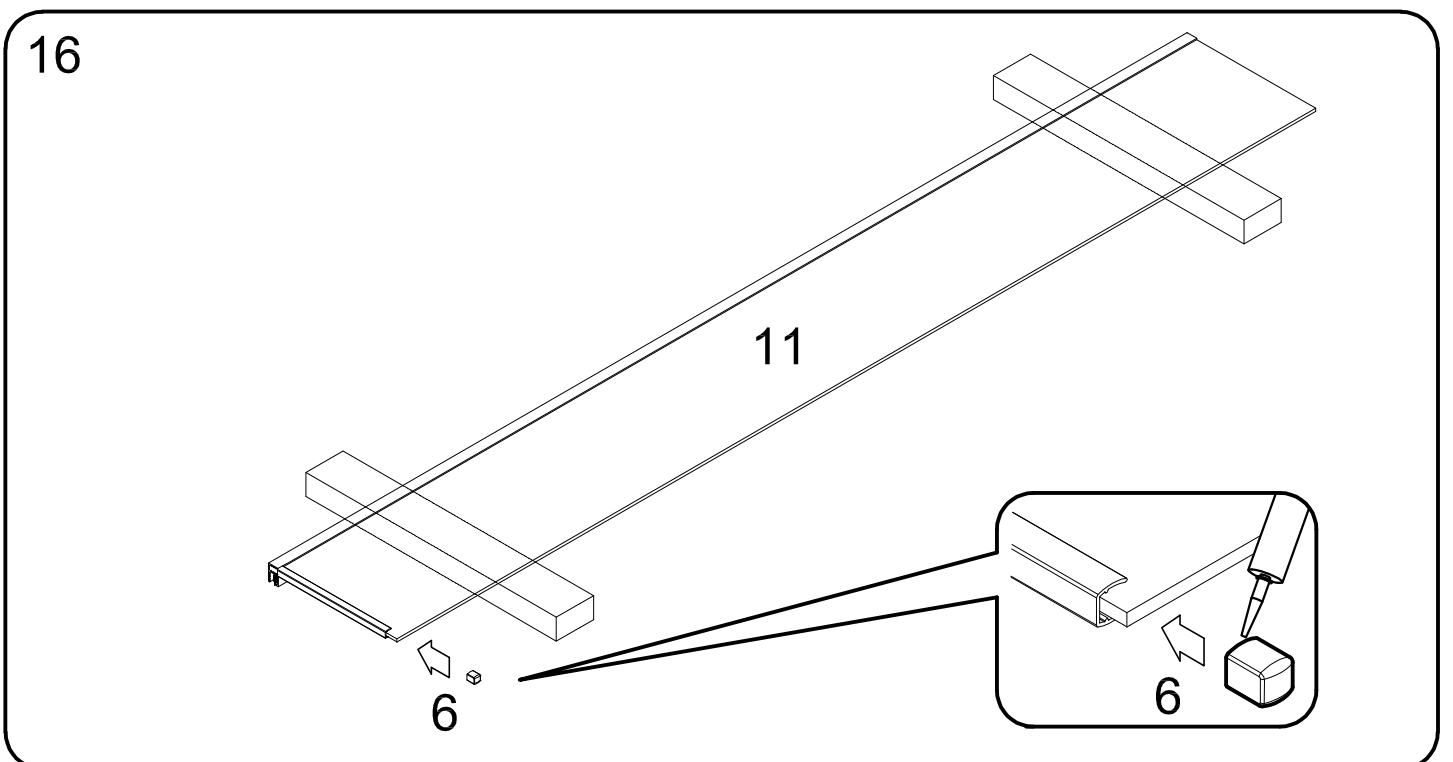
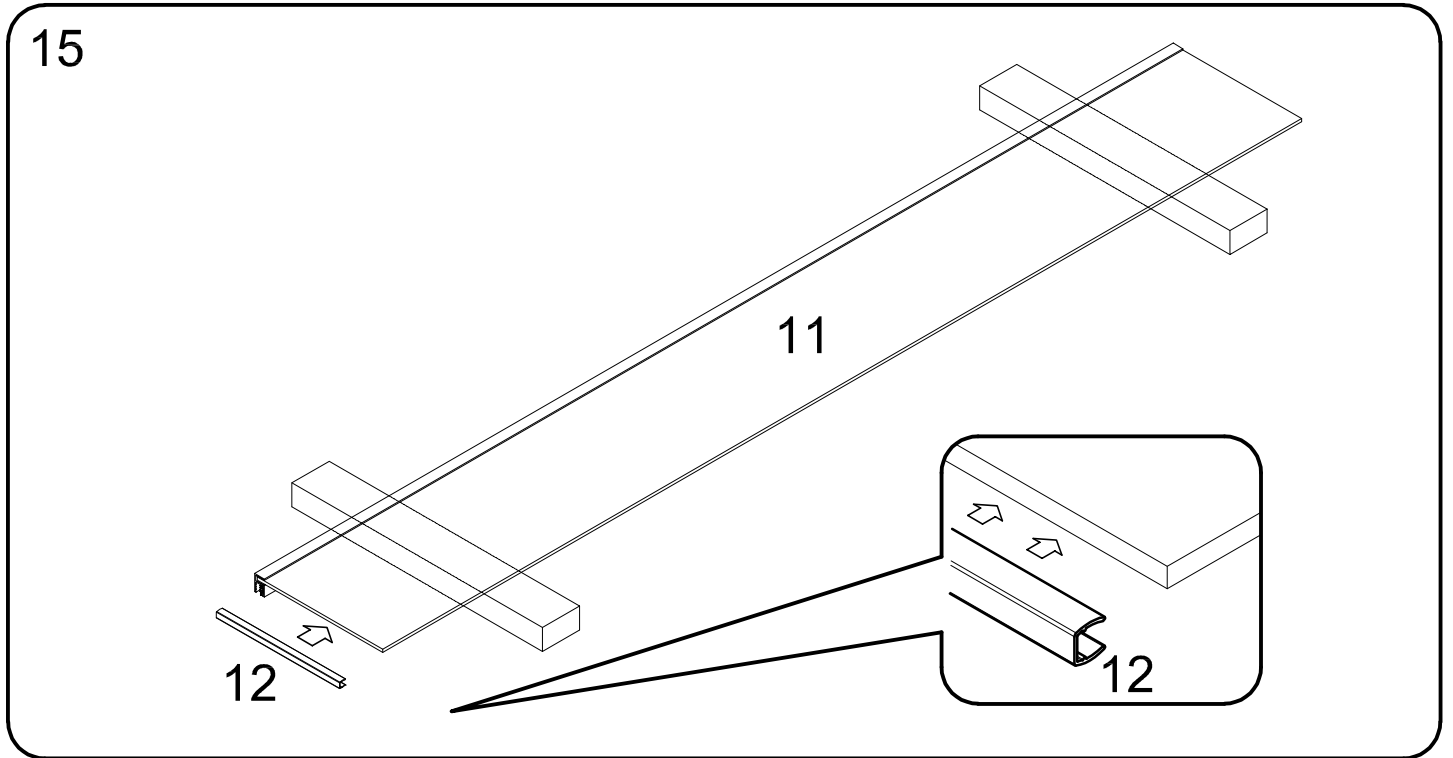
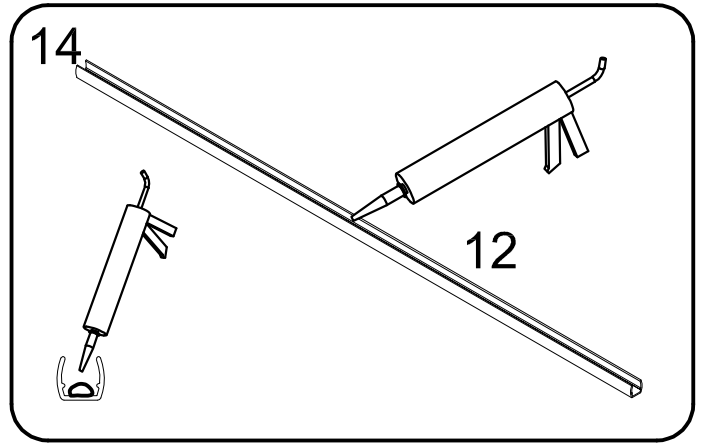
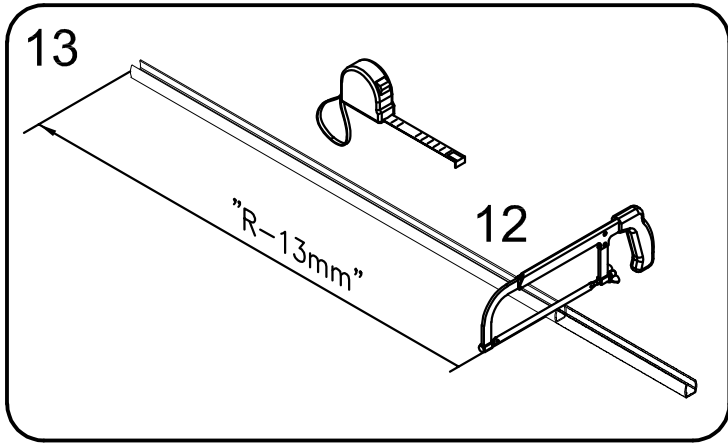

17

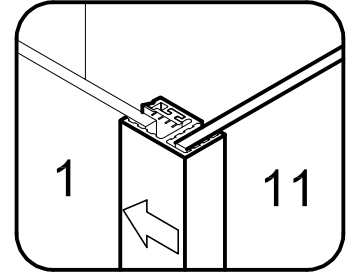
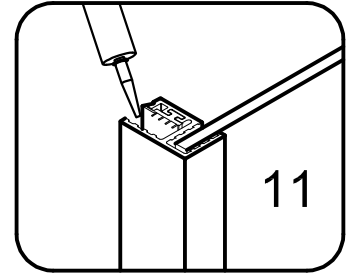
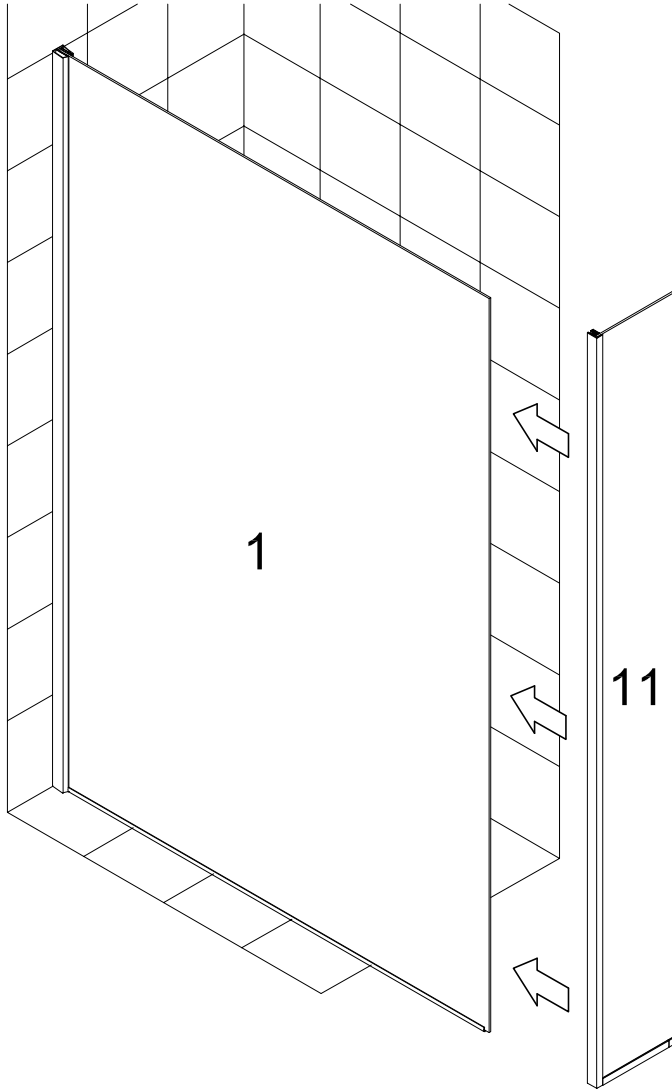

18

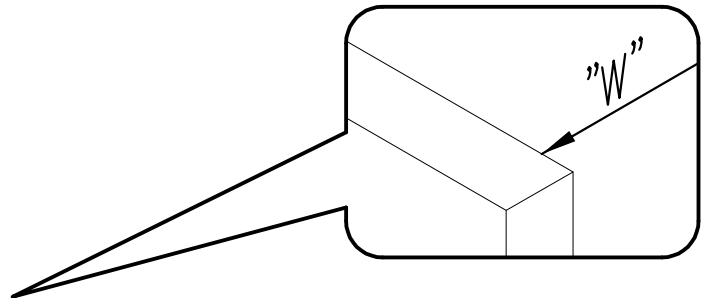
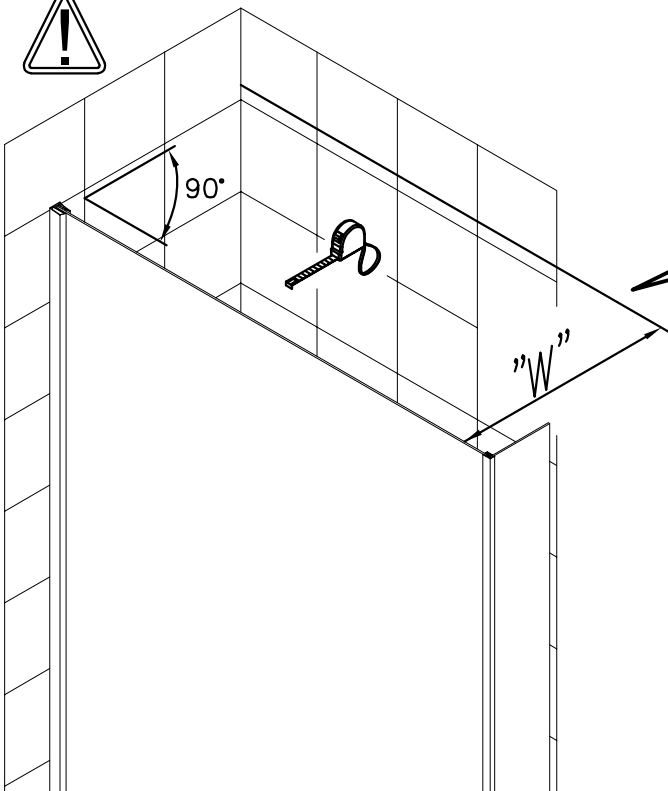

19

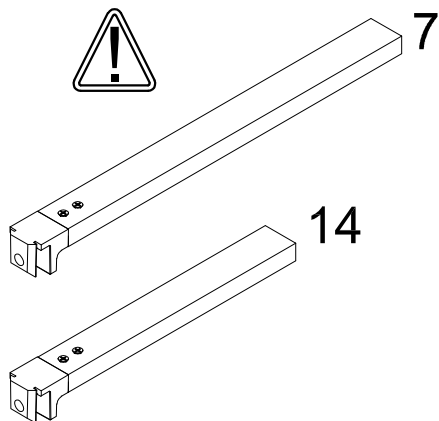

"Z" = (W - 17 ± 1 mm)

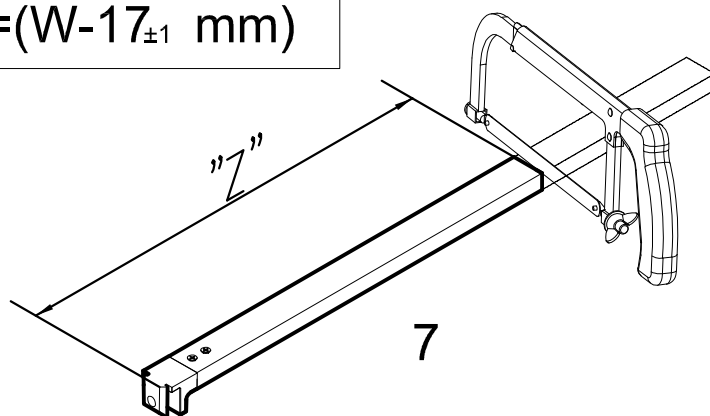

20

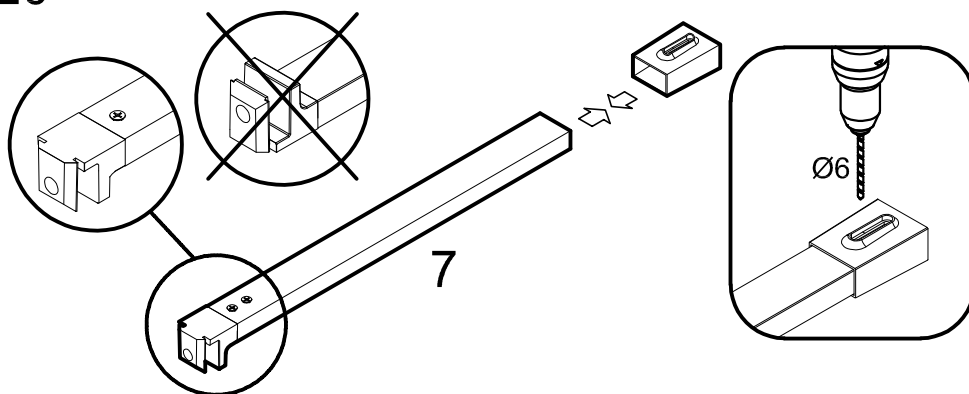

21

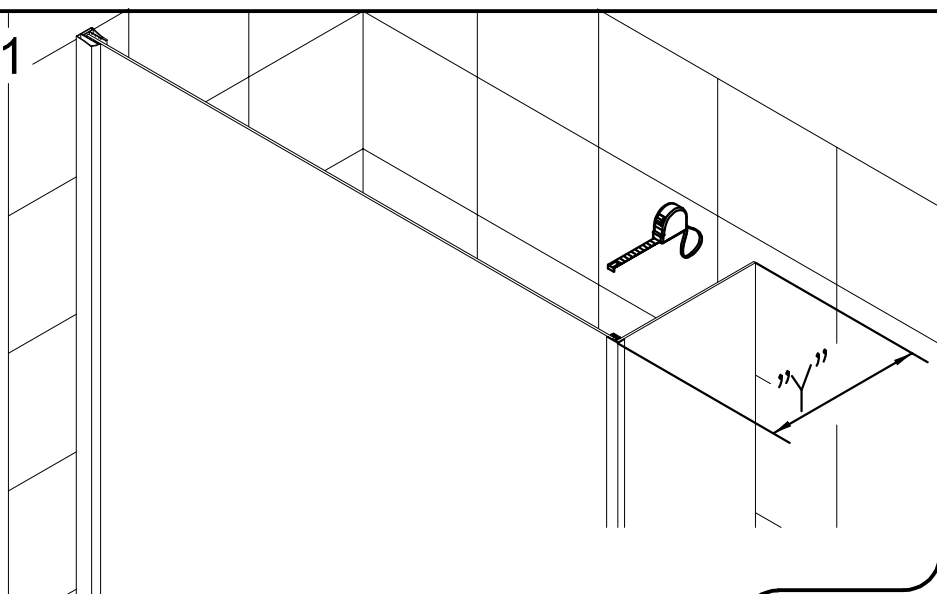

"H" = (Y - 45 mm)

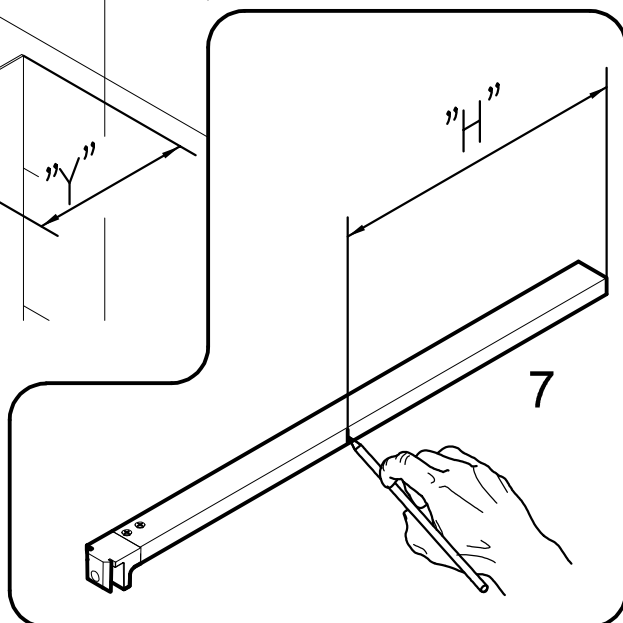

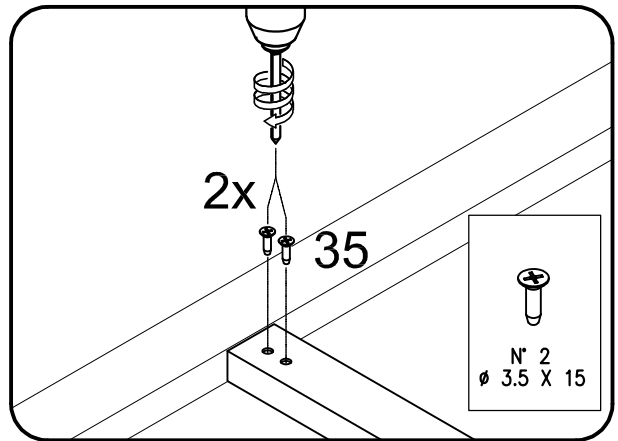
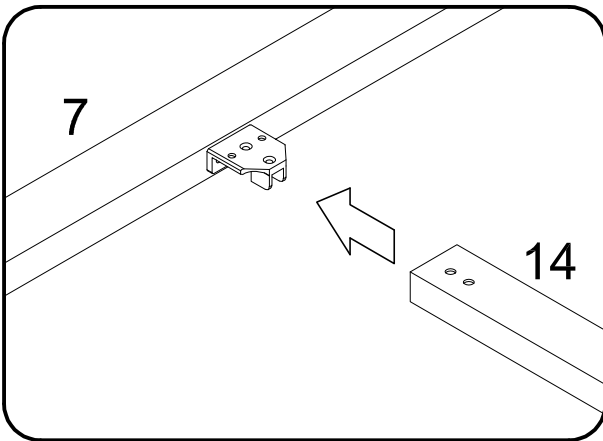
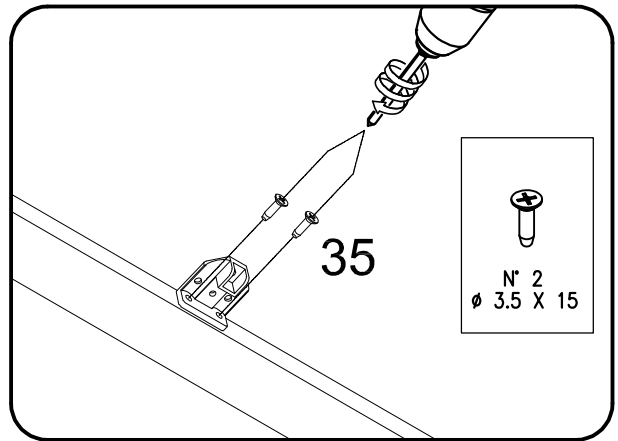
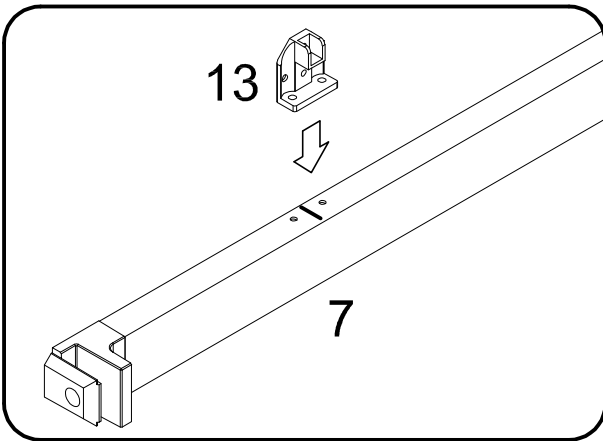
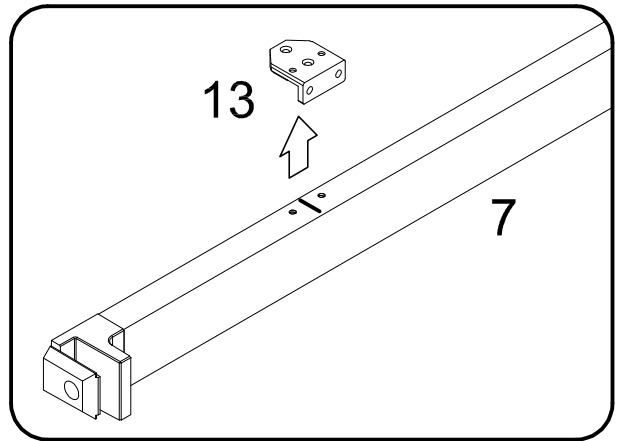
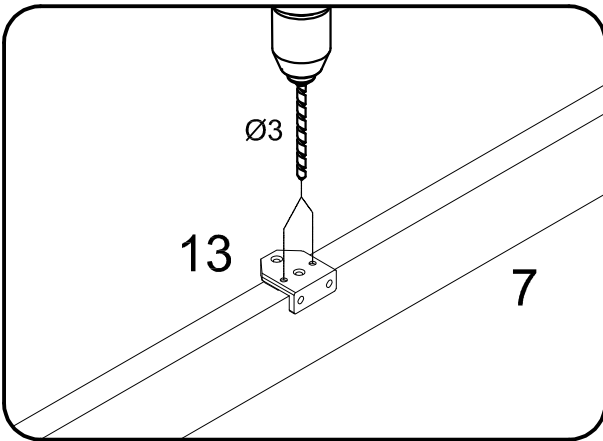
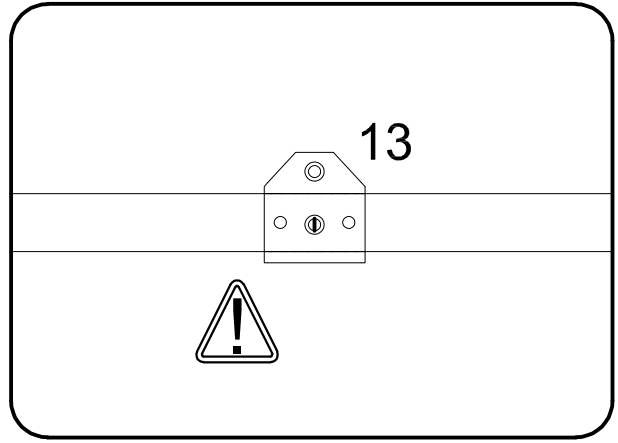
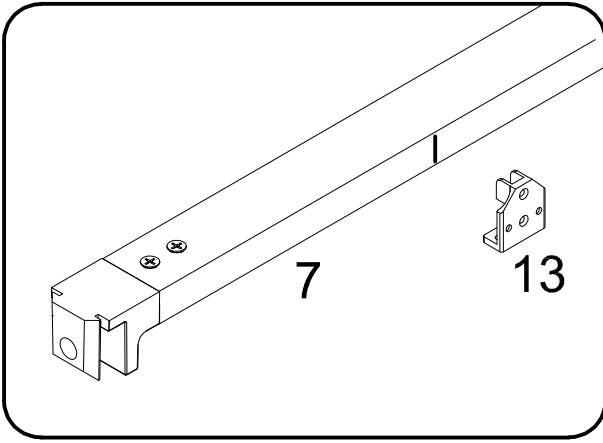

23

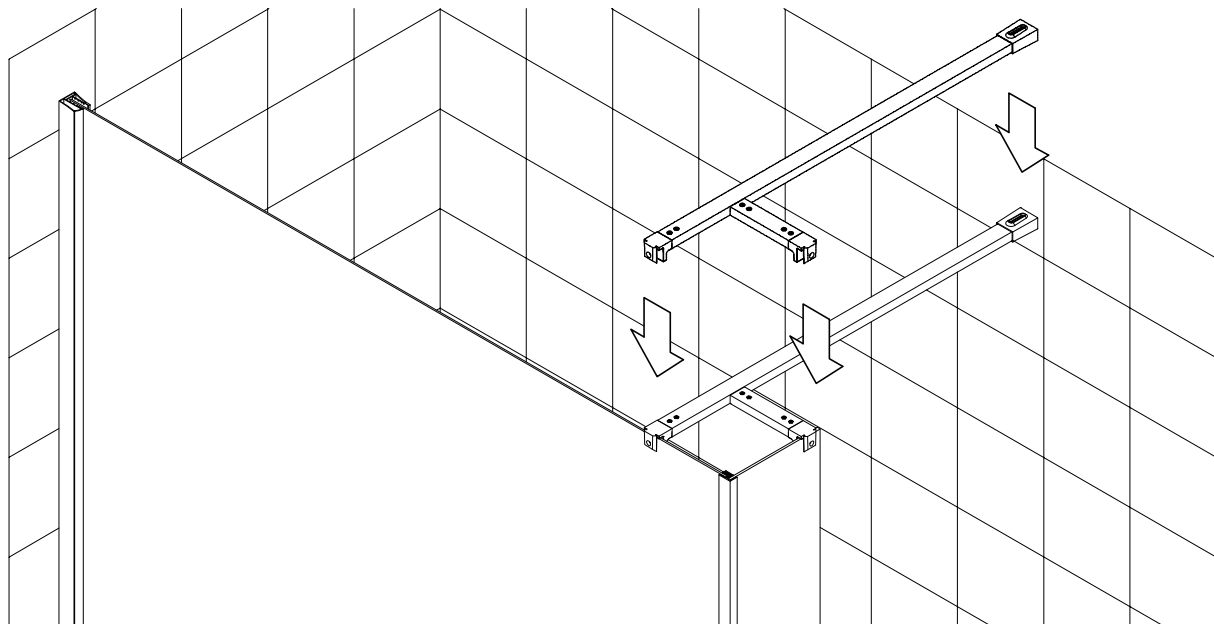

24

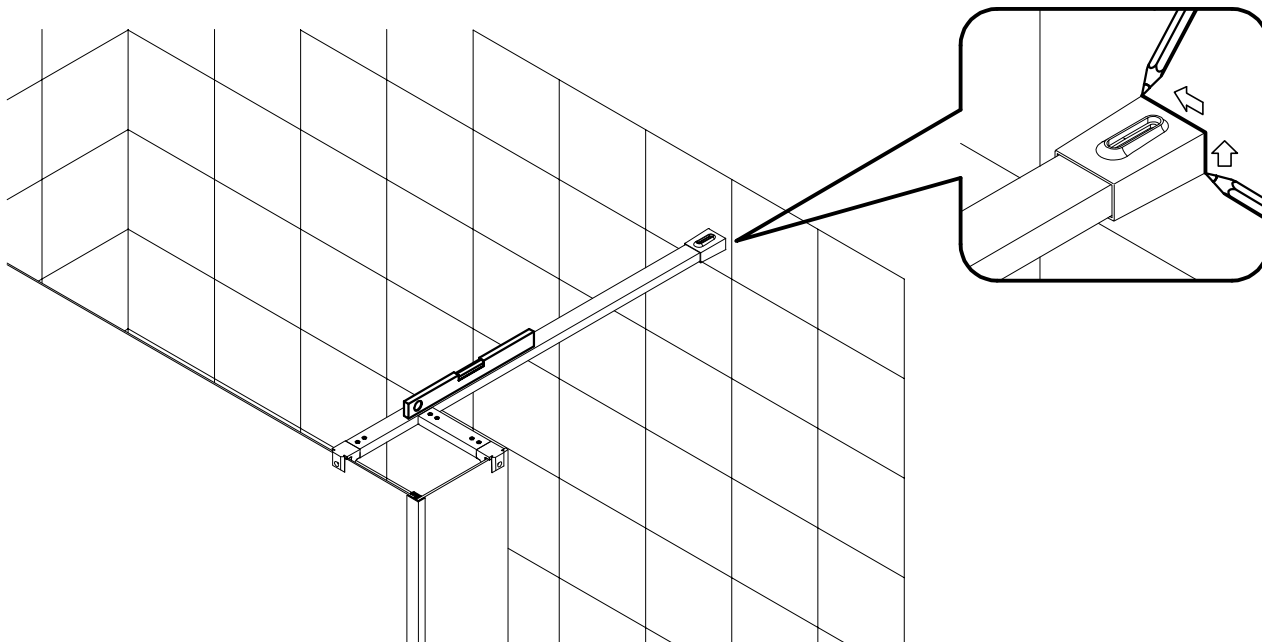

25

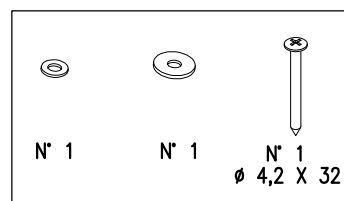
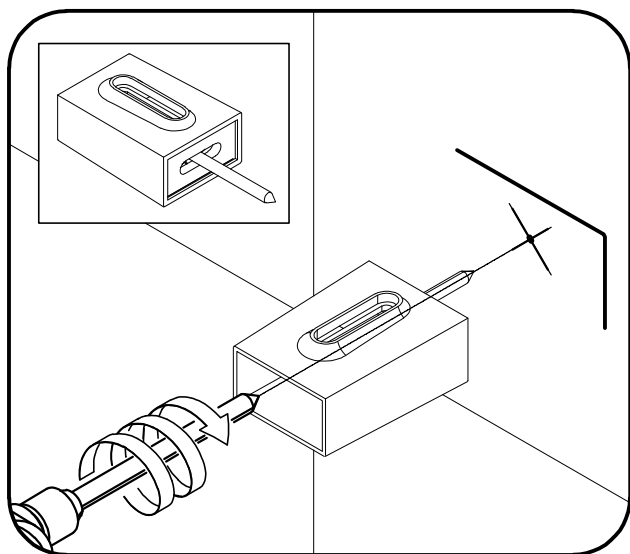
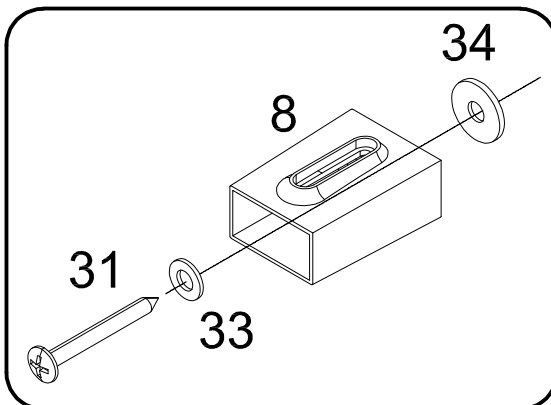
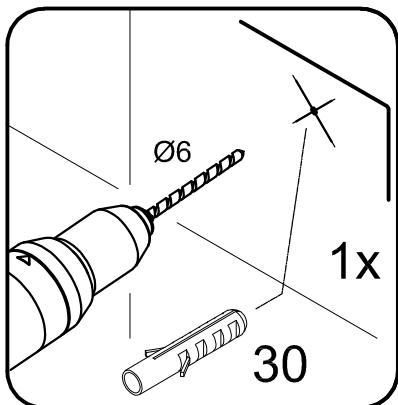
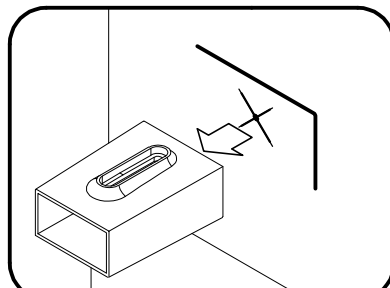
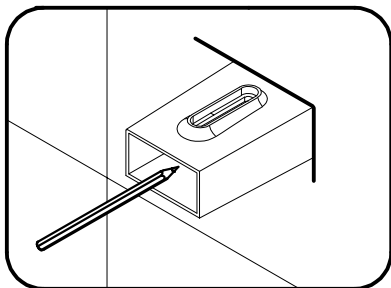
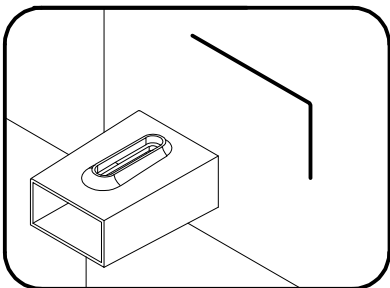
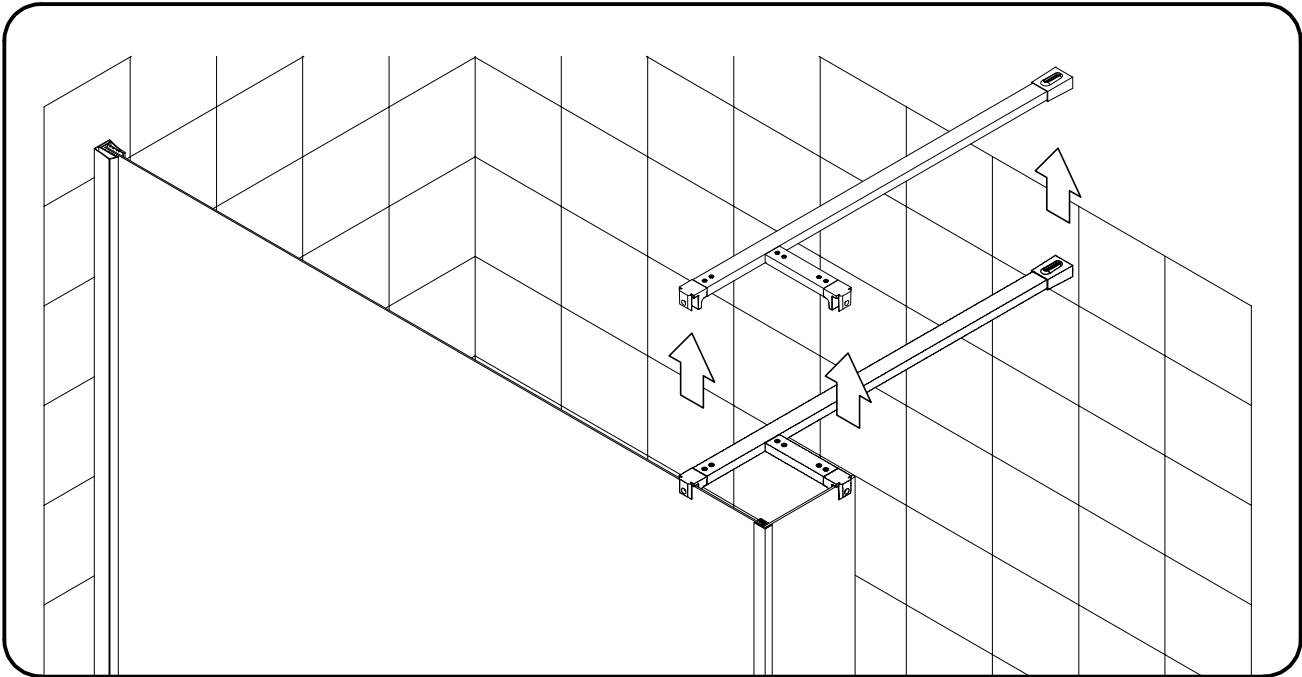

26

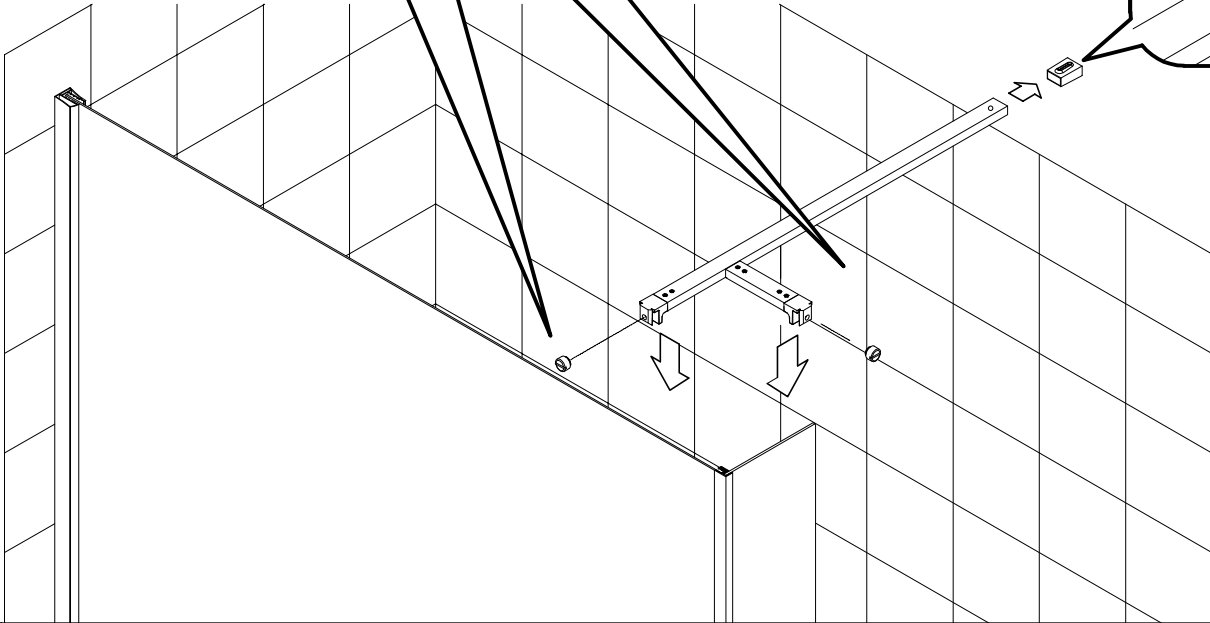
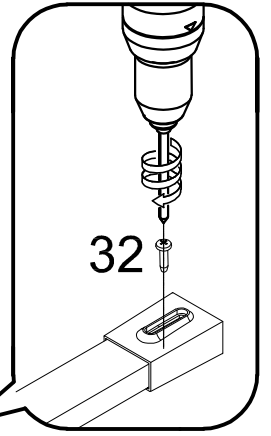
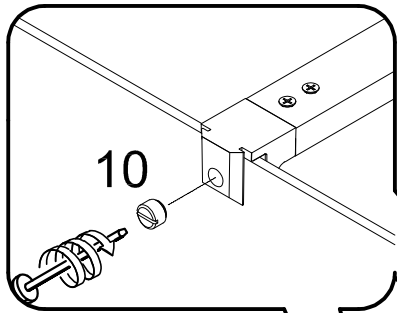

27

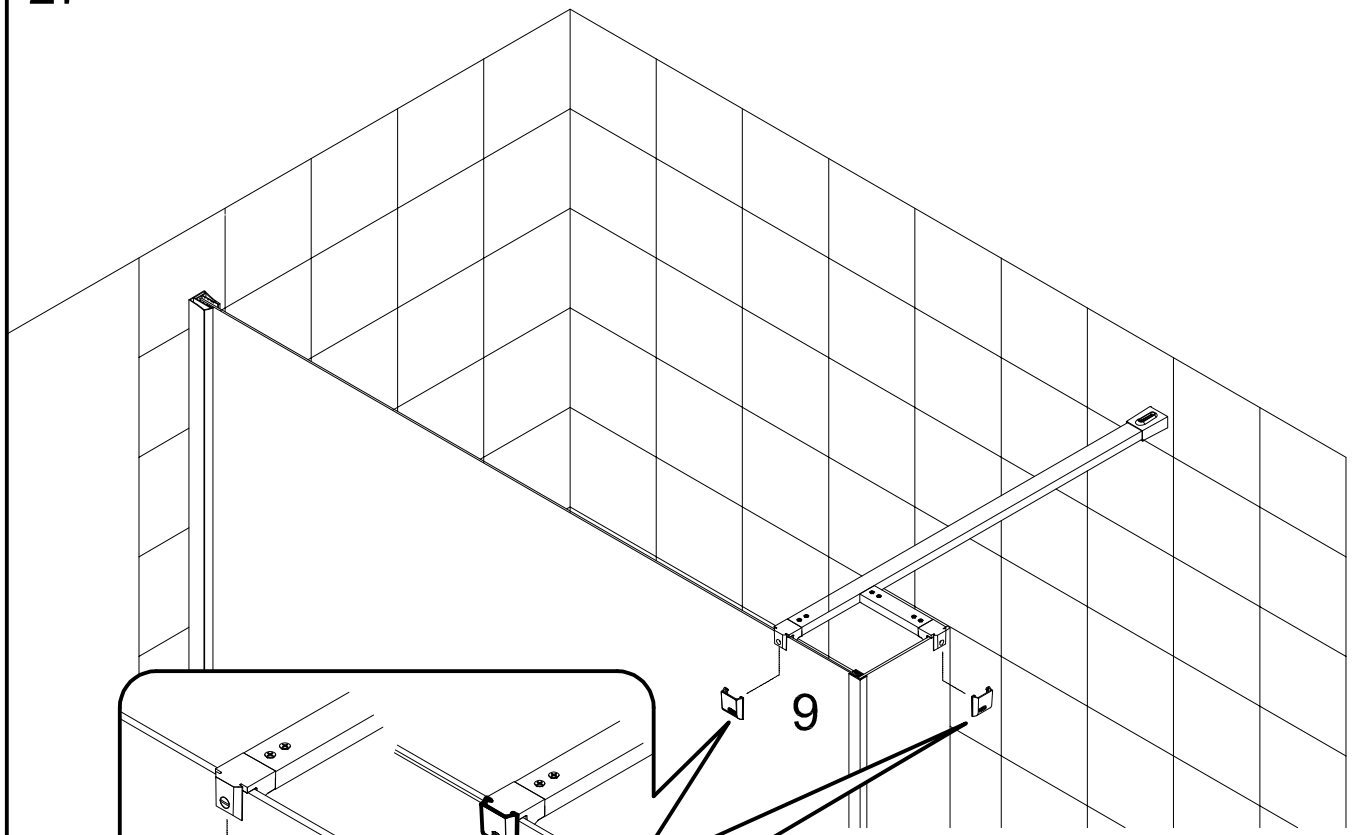
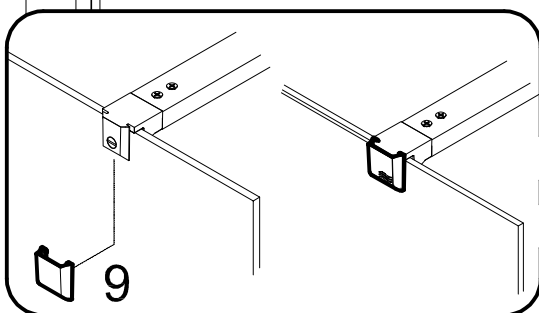



Pag. 1

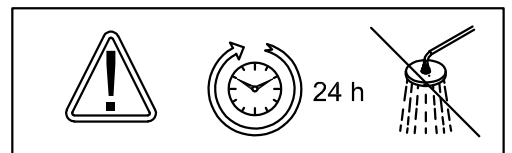
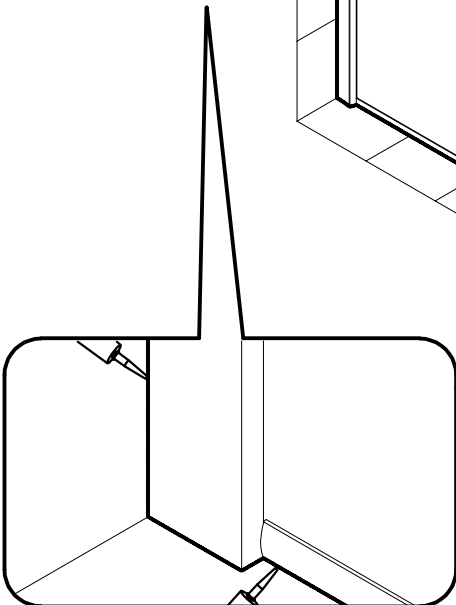
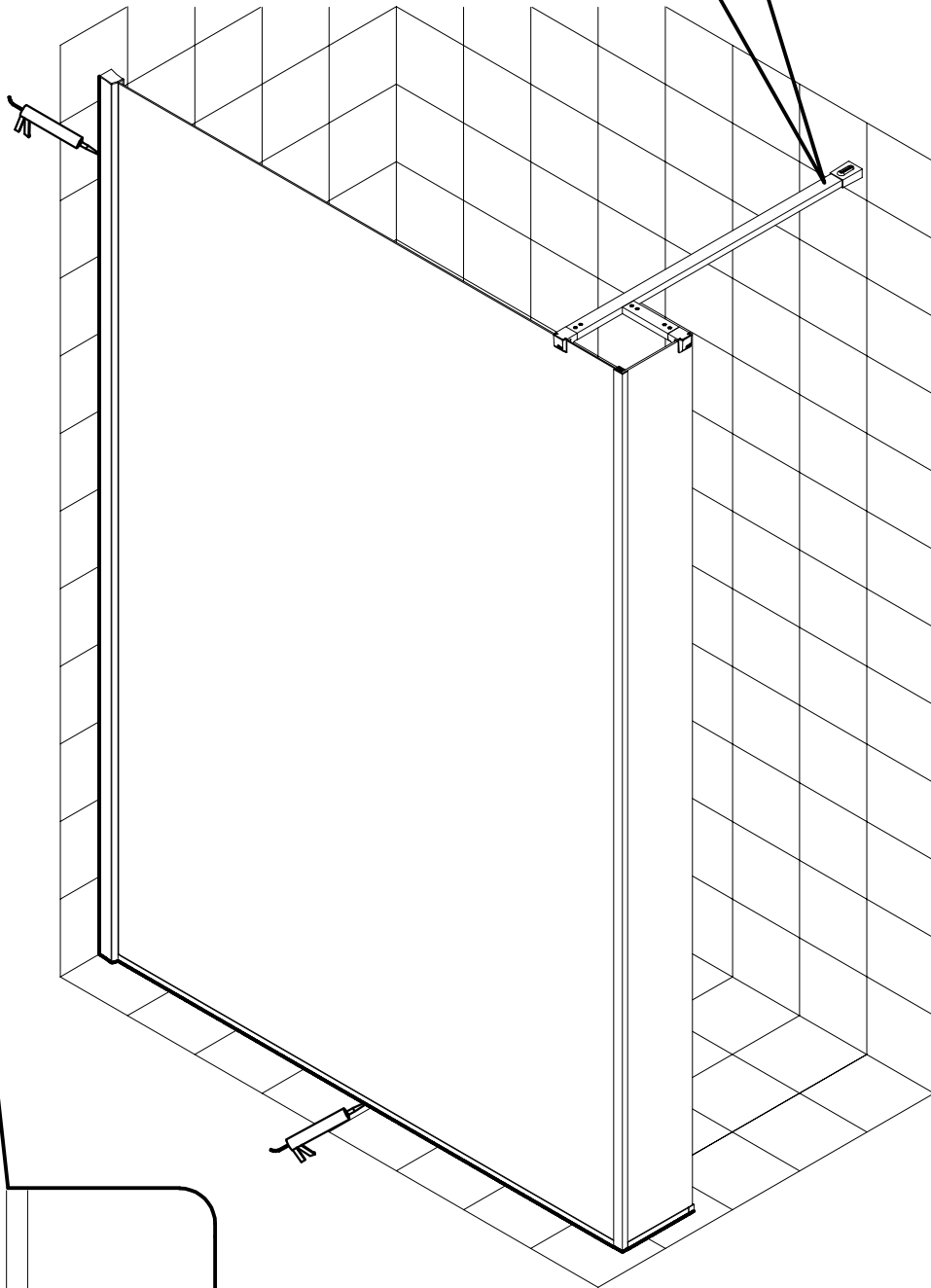
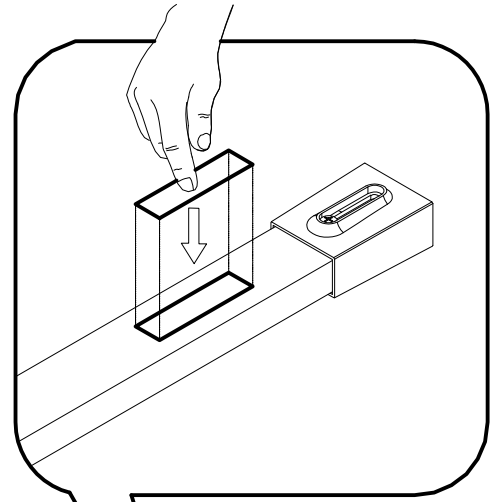
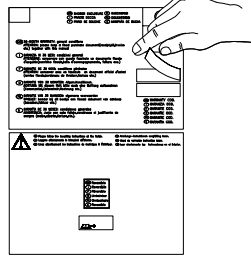

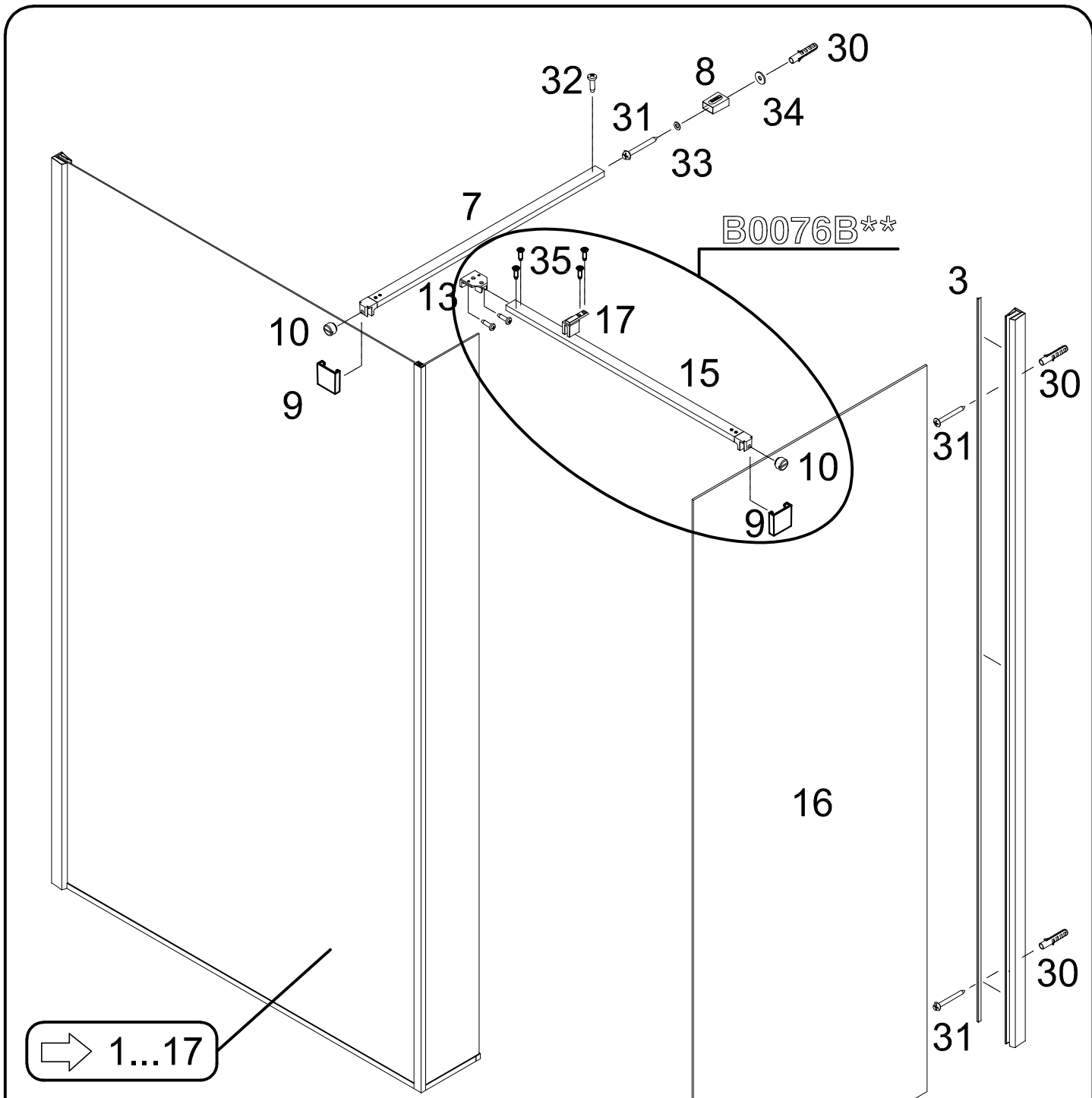

➔ 1...17

30	31	32	33	34	35
N° 3 Ø 6 X 30	N° 3 Ø 4,2 X 32	N° 1 Ø 3,5 X 13	N° 1	N° 1	N° 4 Ø 3,5 X 13



RBAL141343**

RBCF1260

RBCF01600

RBAL1343**

RBAL1347**

RBGV123600

RBAL073**

RBAL074**

RBPL1348**

RBAL1388**

➔ 1...17

B2590C	RBALR122041**
B2592C	RBALR122041**

RBPL1345**

RBAL1388**

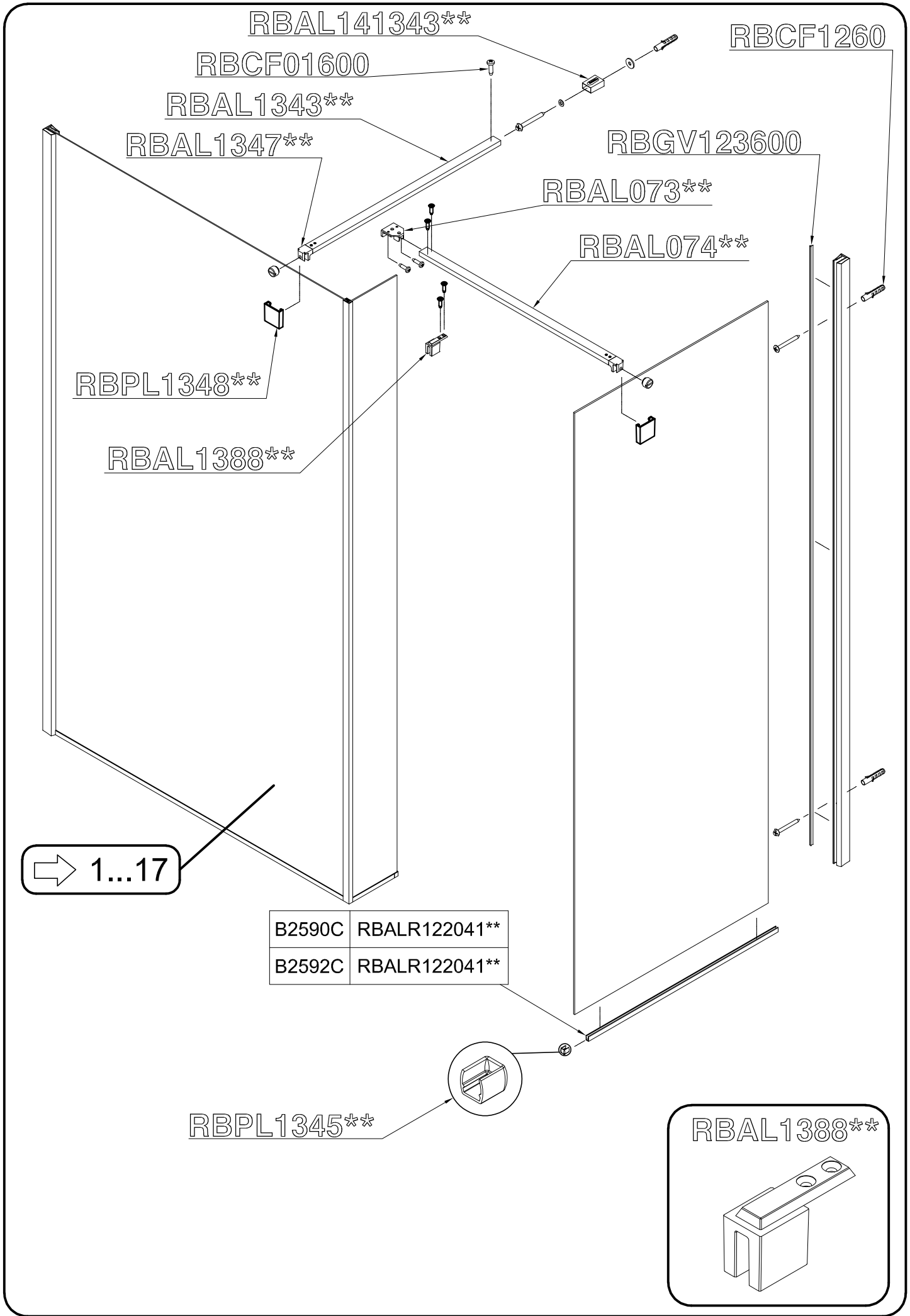
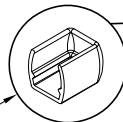
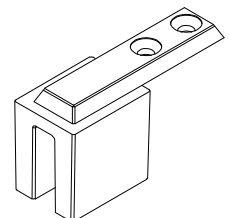

29

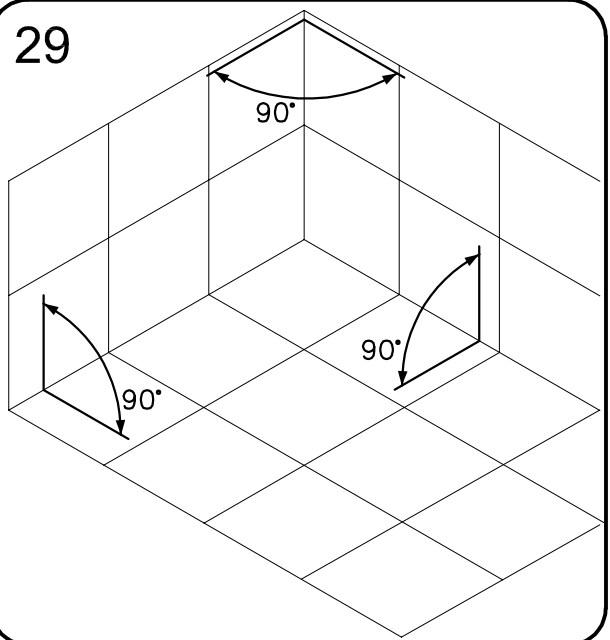

B2590A		
B2591A		
B2592A		
B2593A		
B2594A		
B2595A	B2590B	B2590C
B2596A	B2591B	B2592C

30

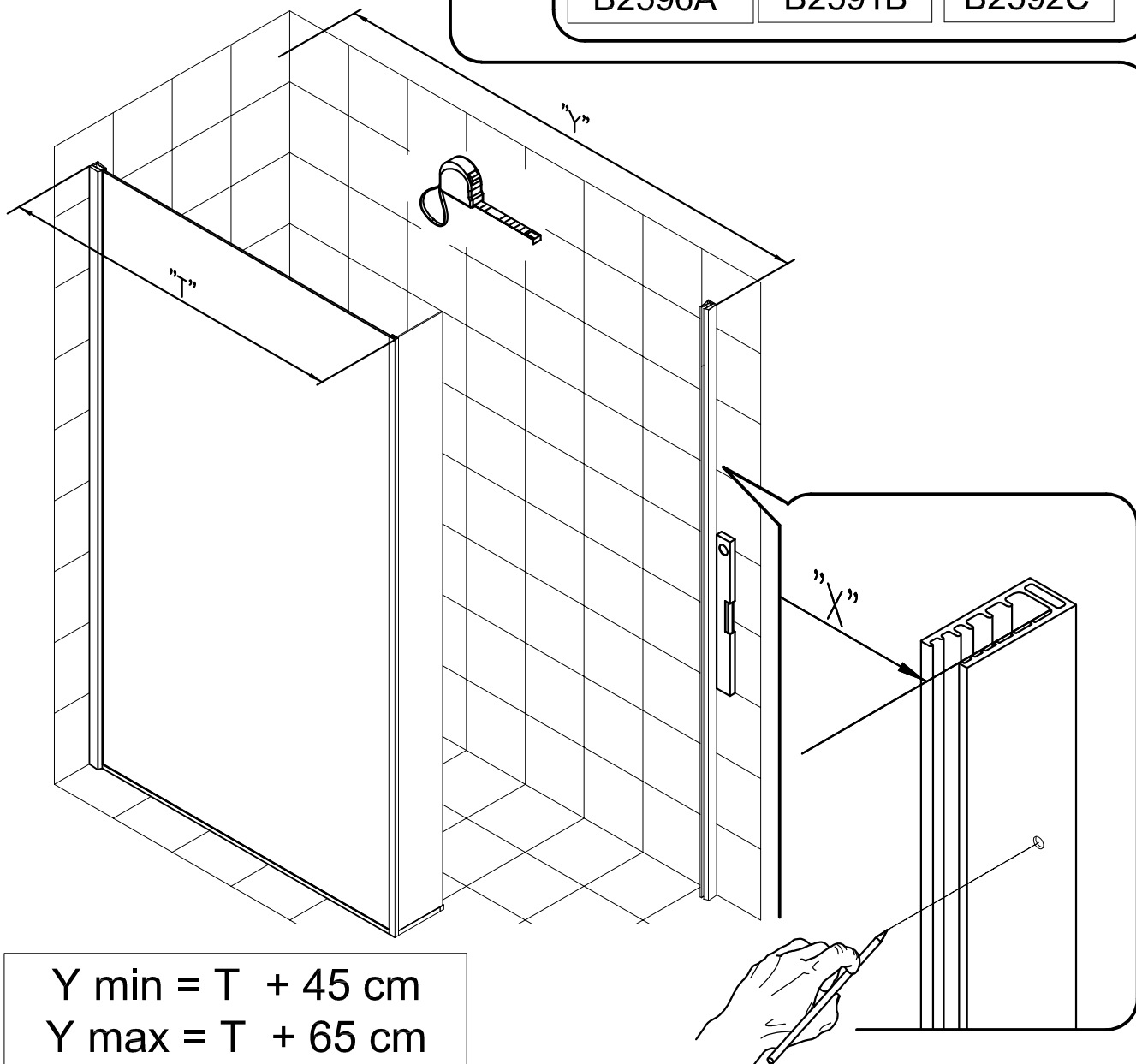

$Y \text{ min} = T + 45 \text{ cm}$
 $Y \text{ max} = T + 65 \text{ cm}$

31

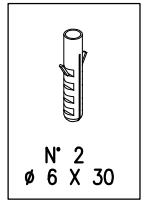
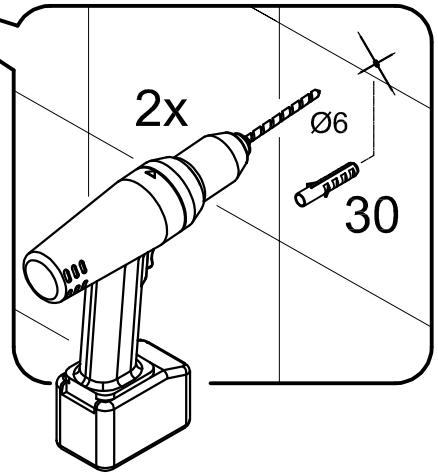
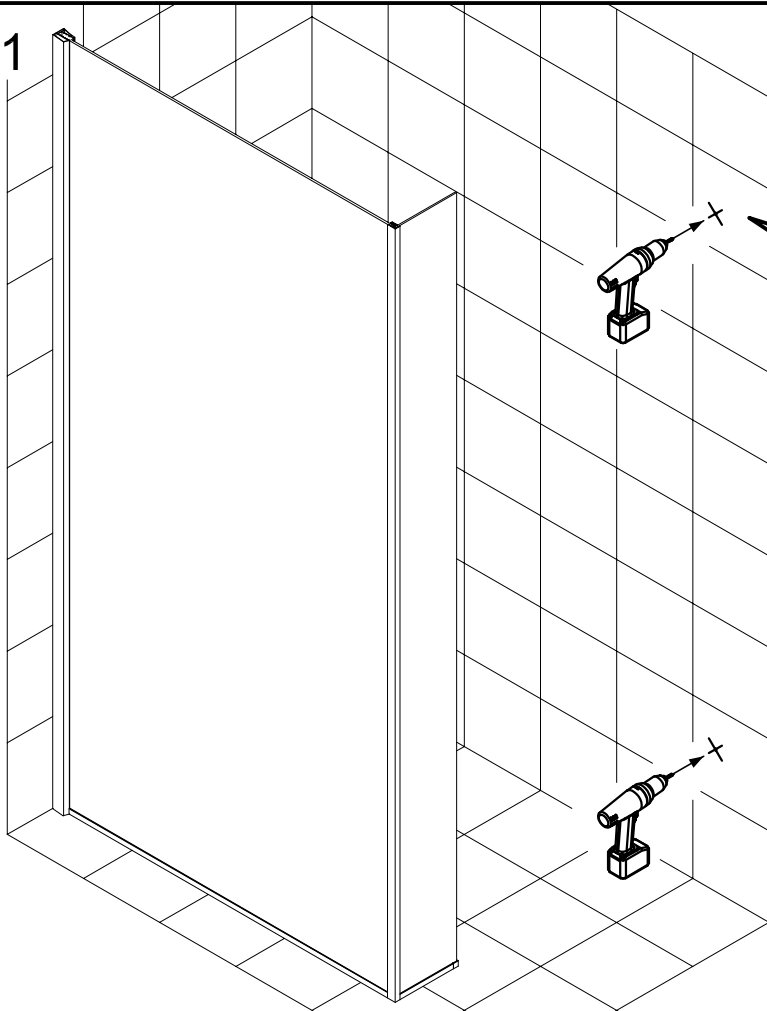

32

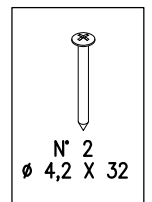
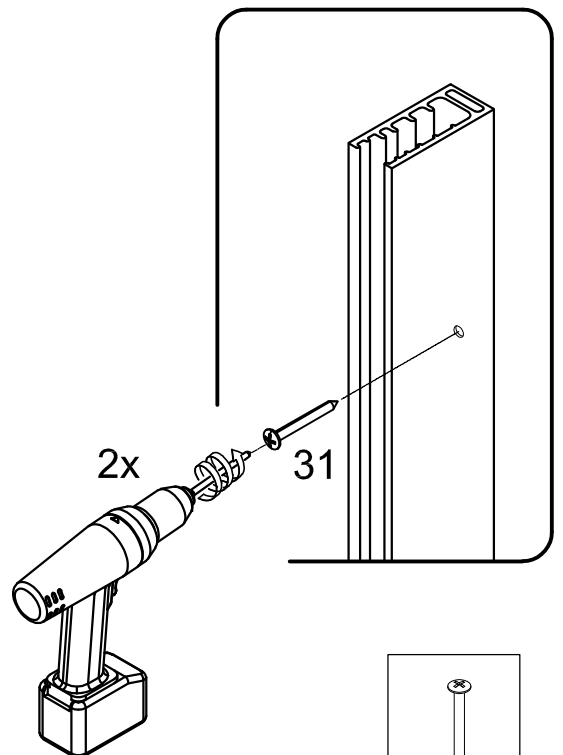
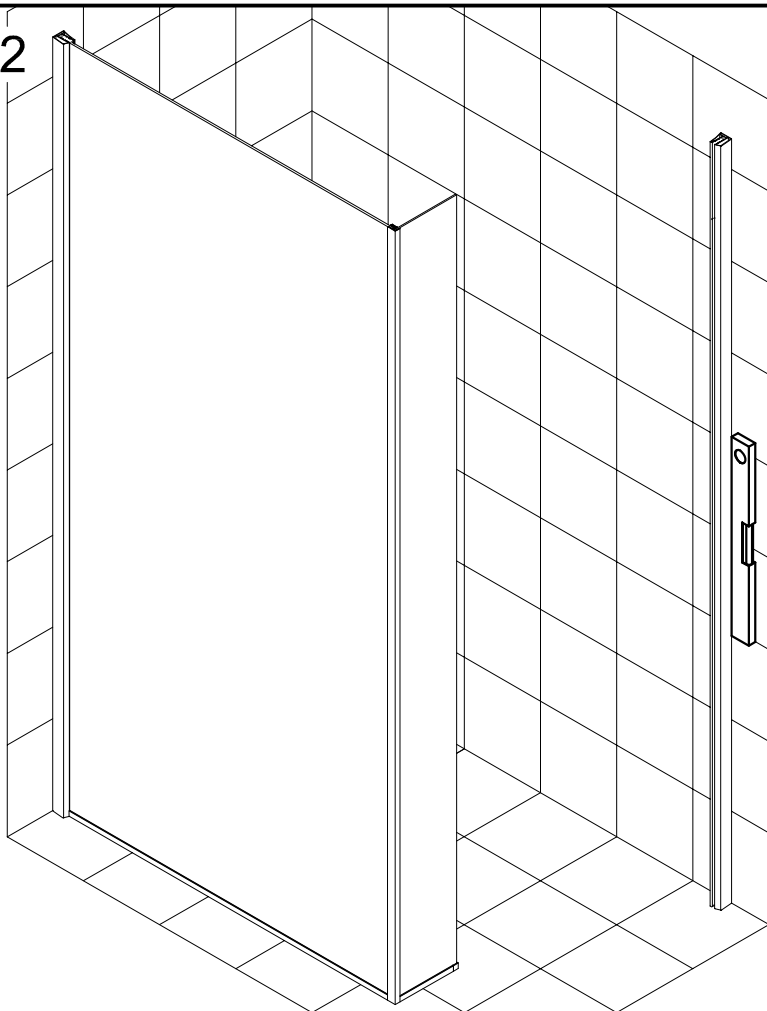

33

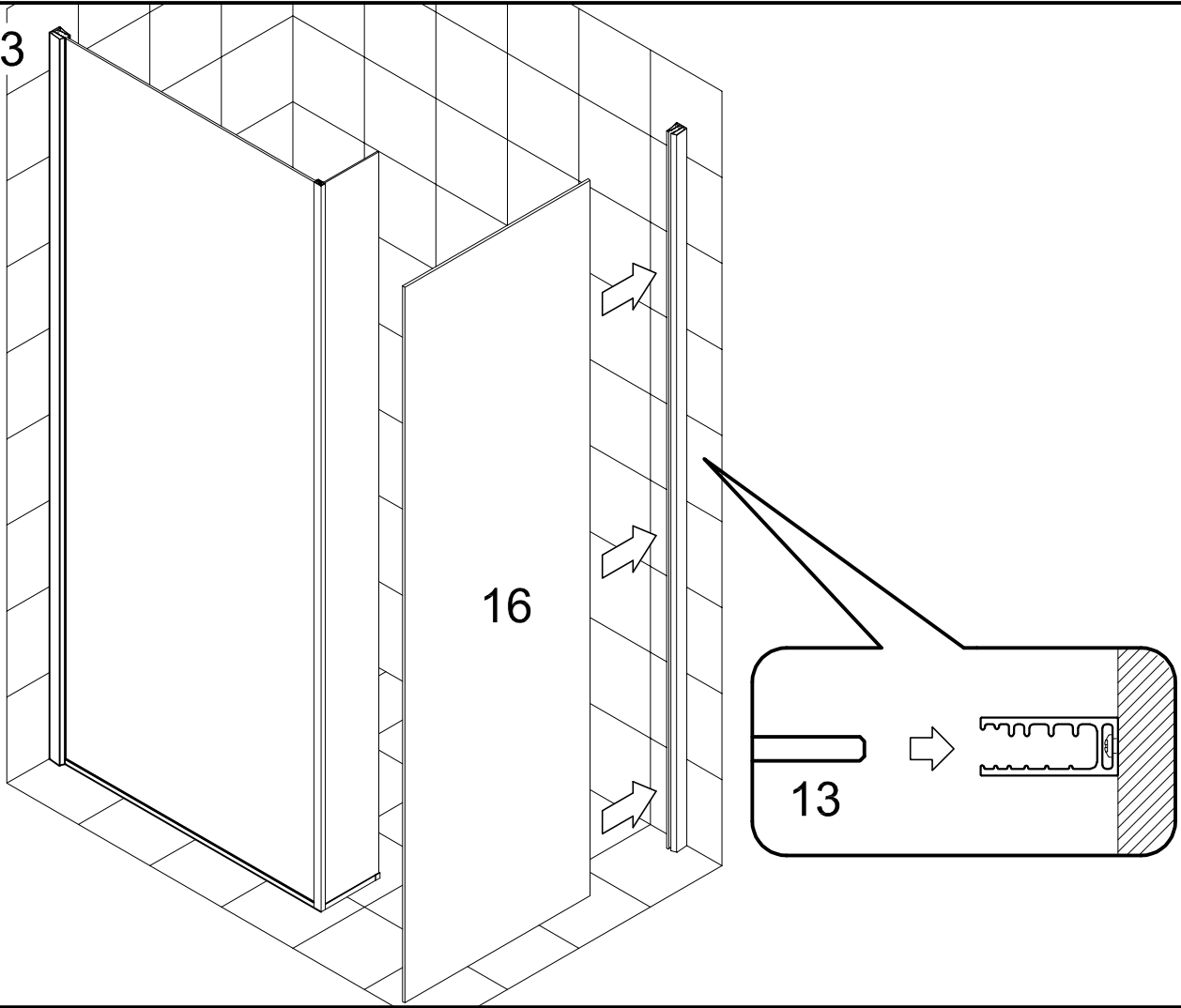

34

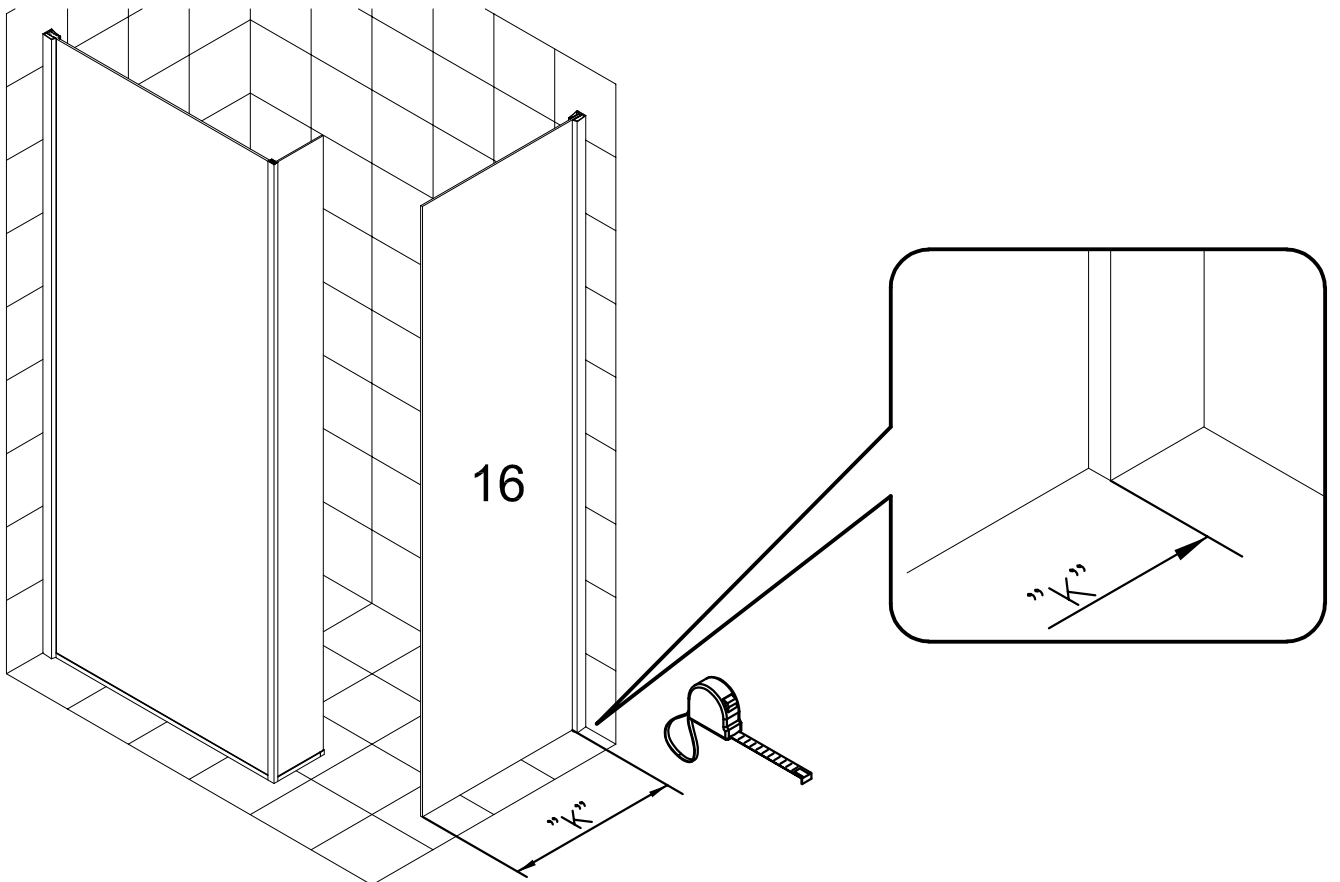

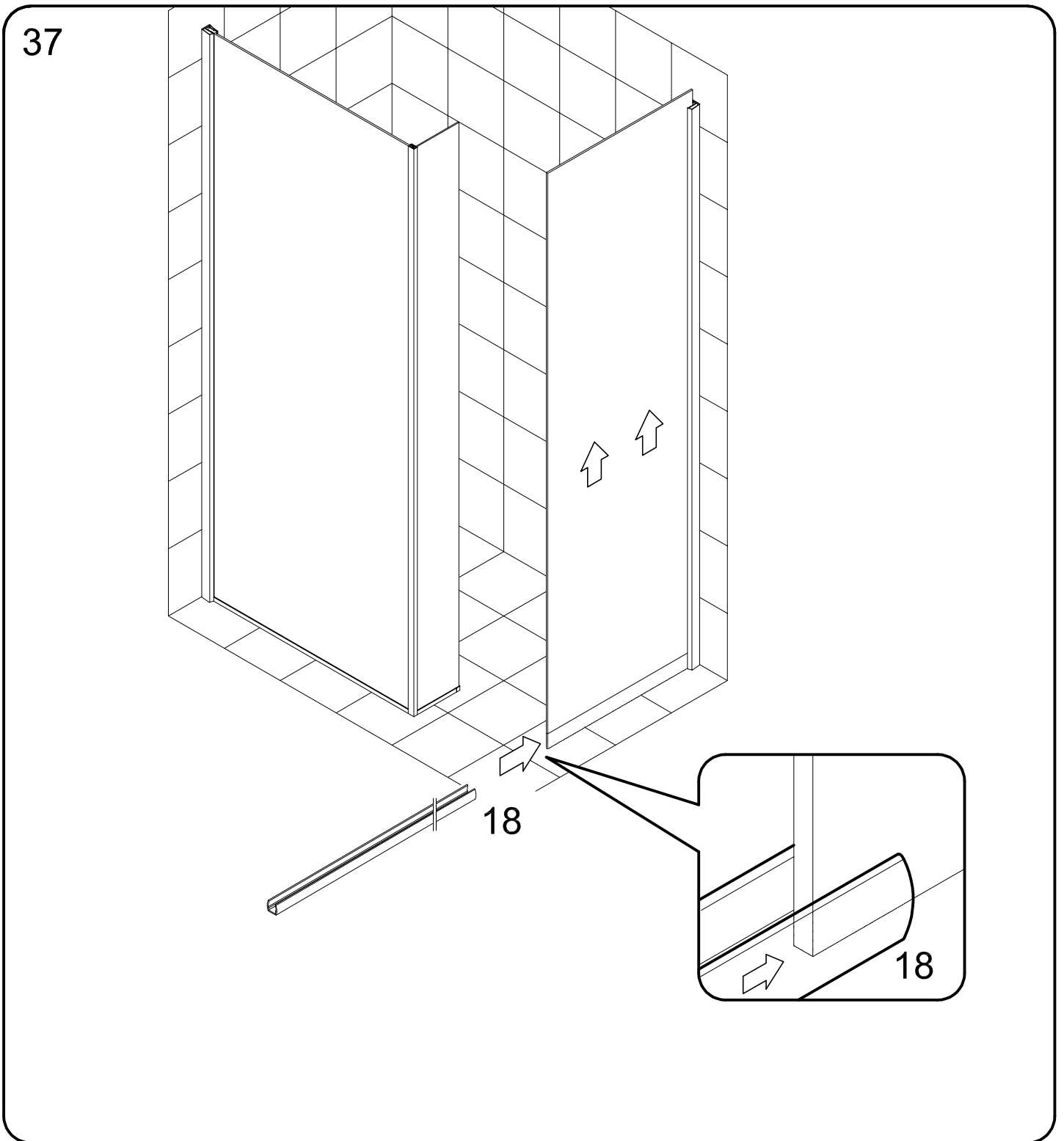
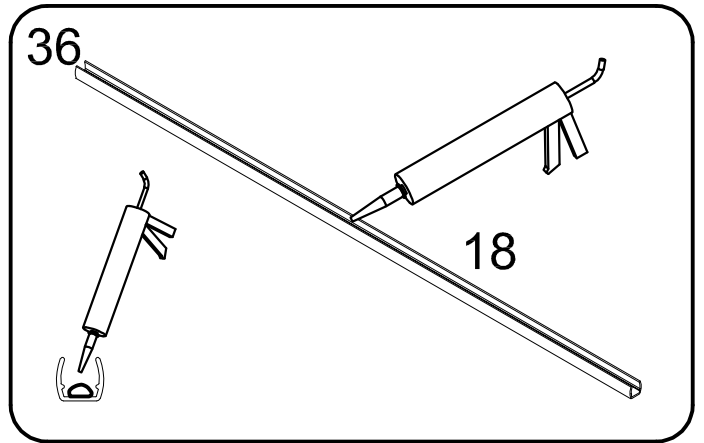
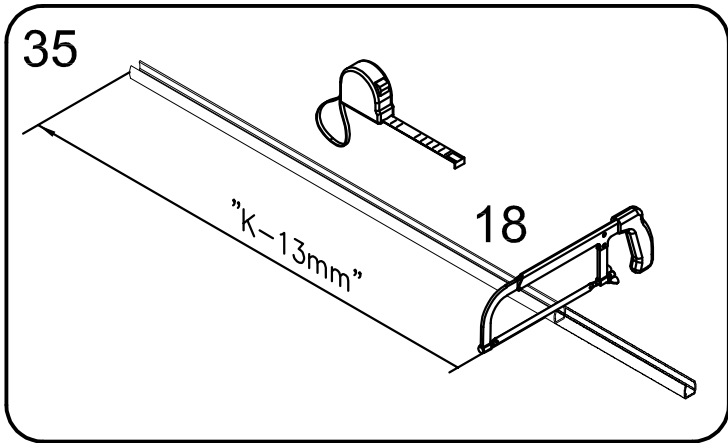

38

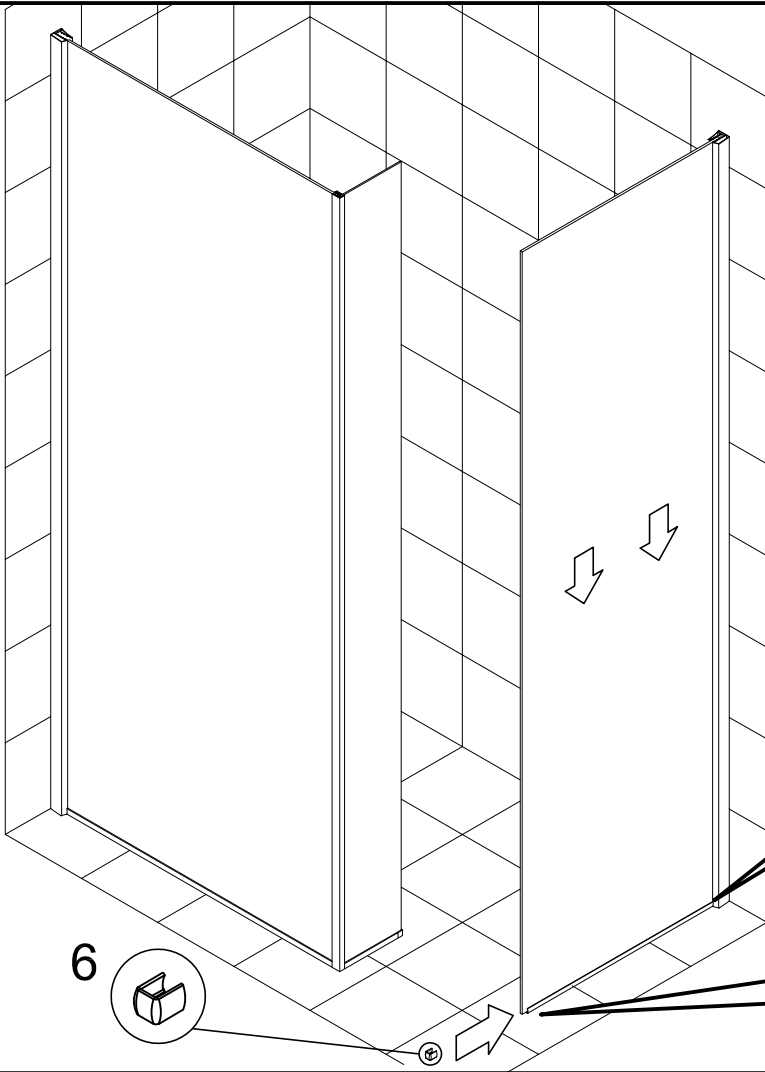

6

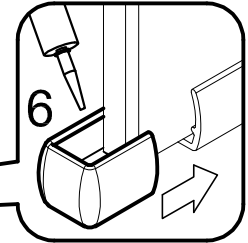
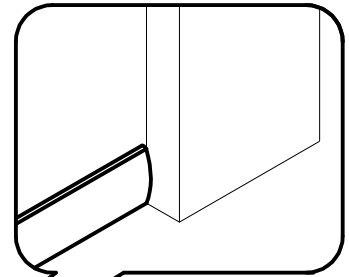

39

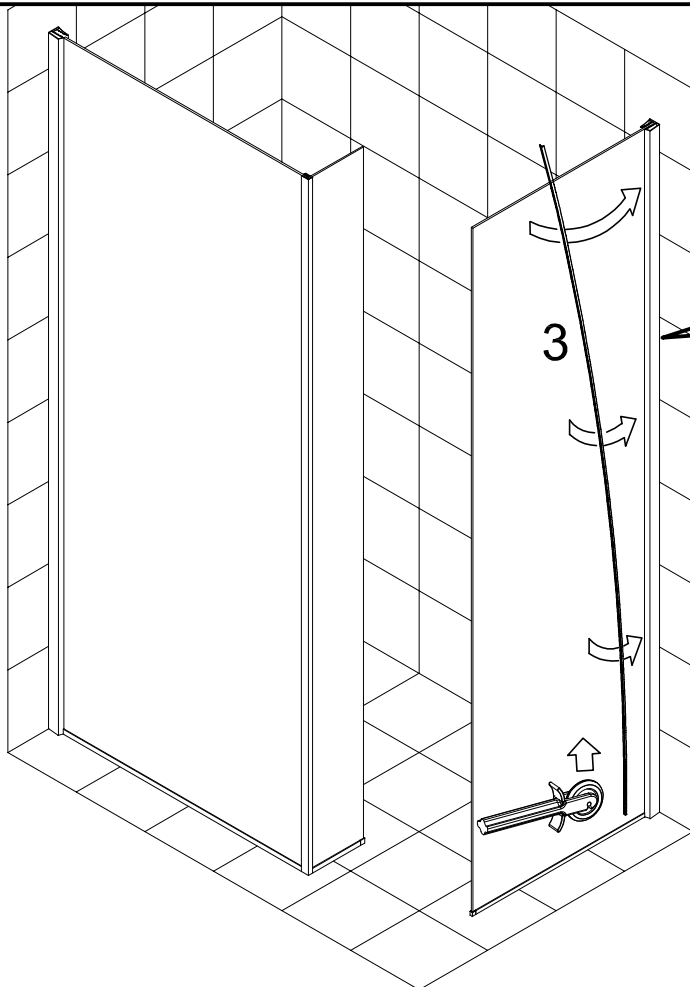

3

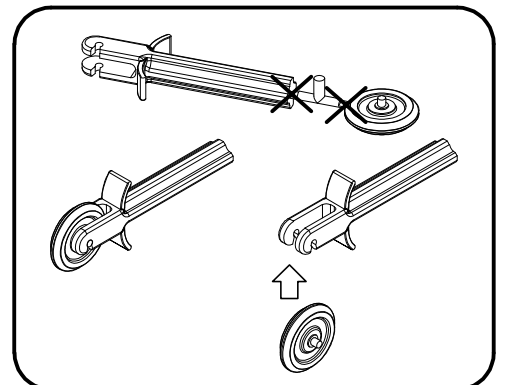
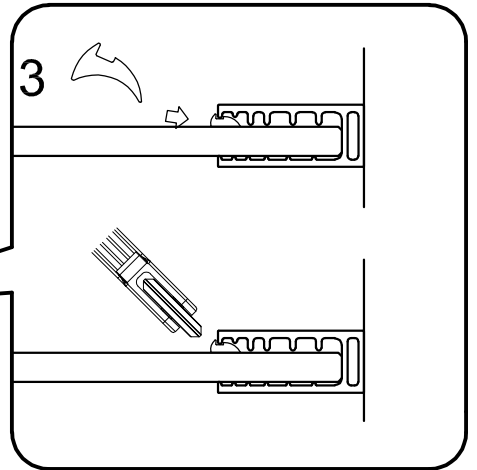

40

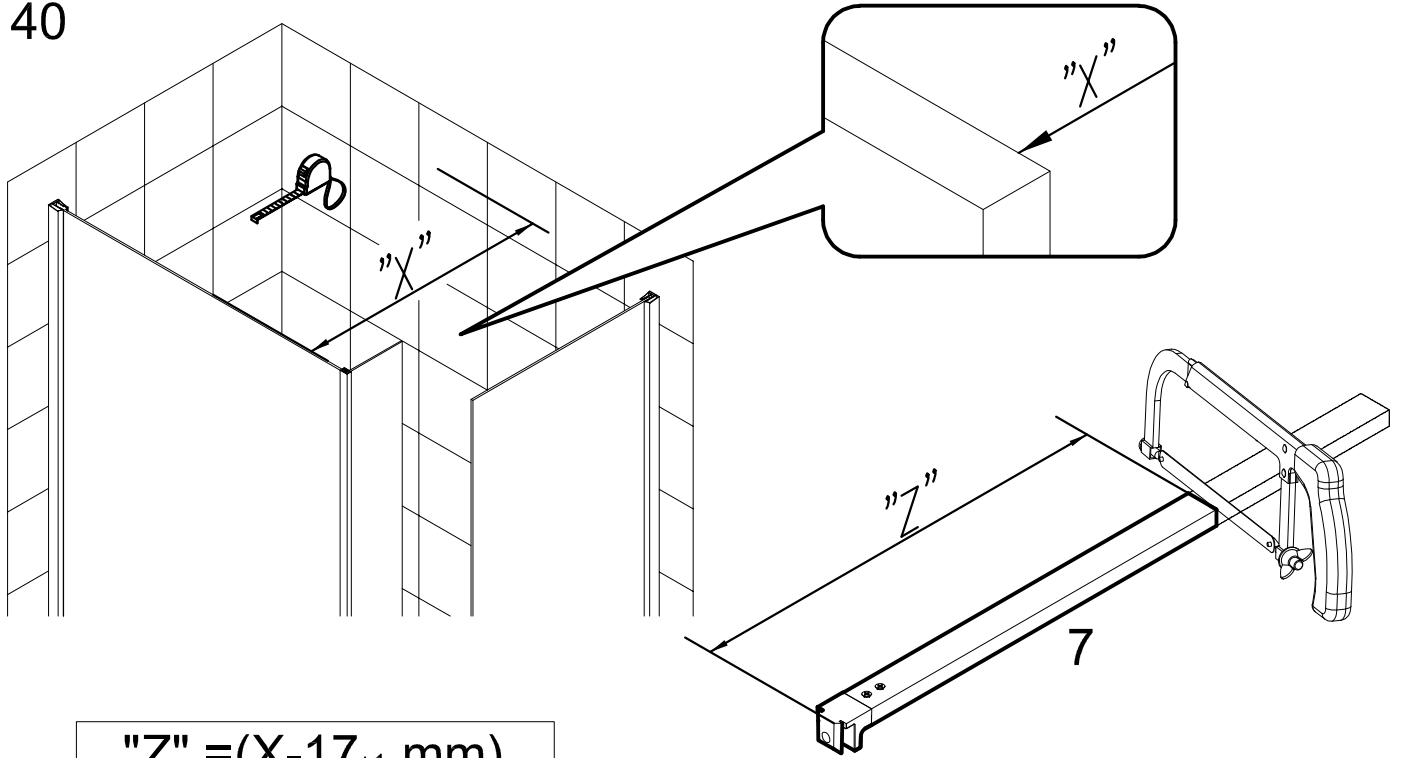

"Z" = (X - 17 ± 1 mm)

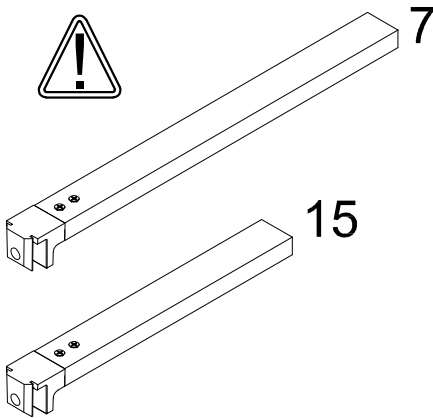

39

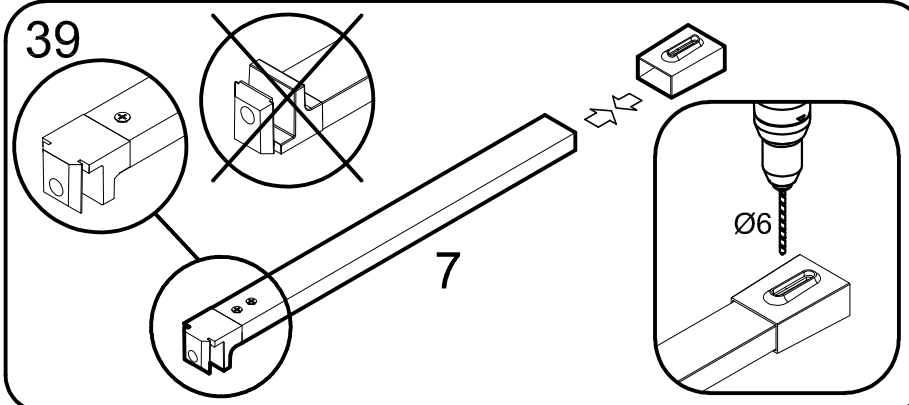

41

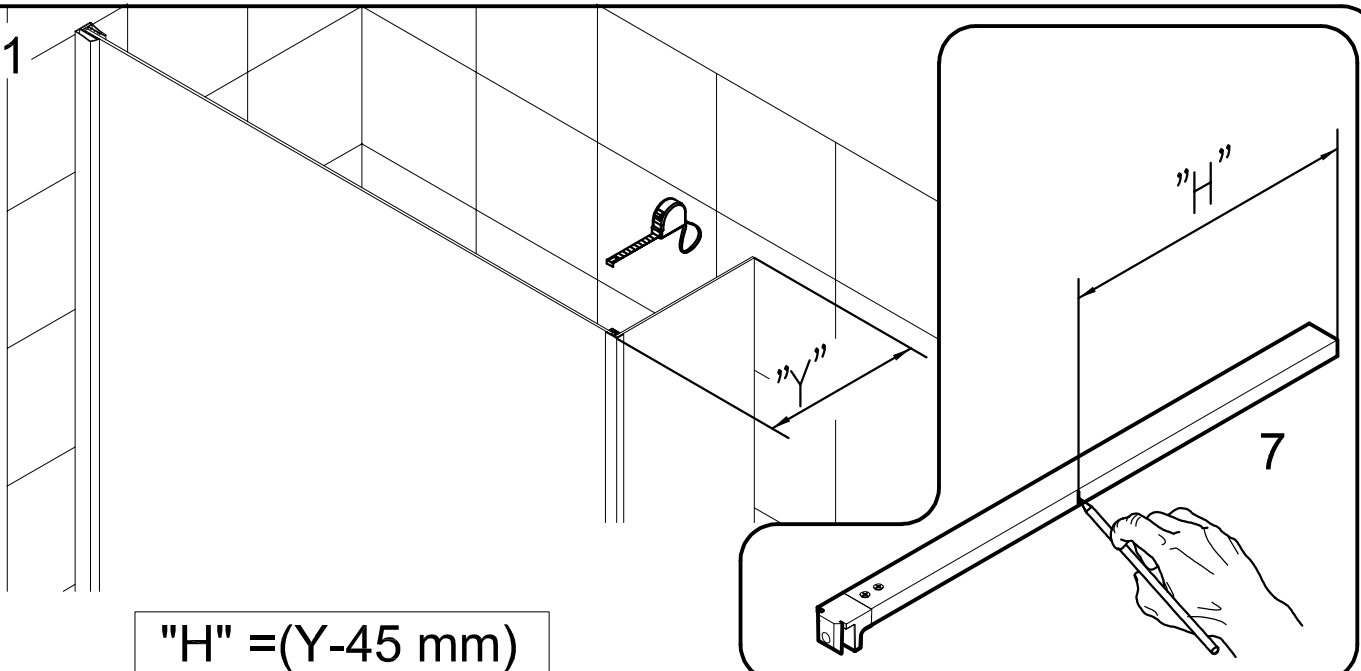

"H" = (Y - 45 mm)

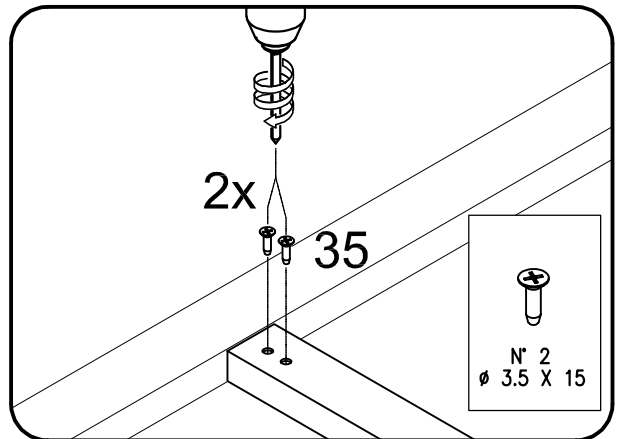
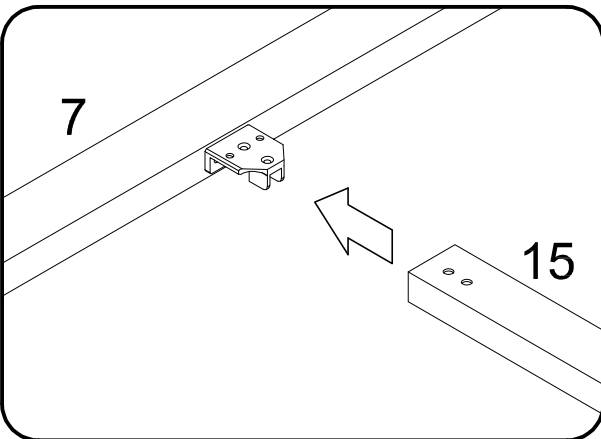
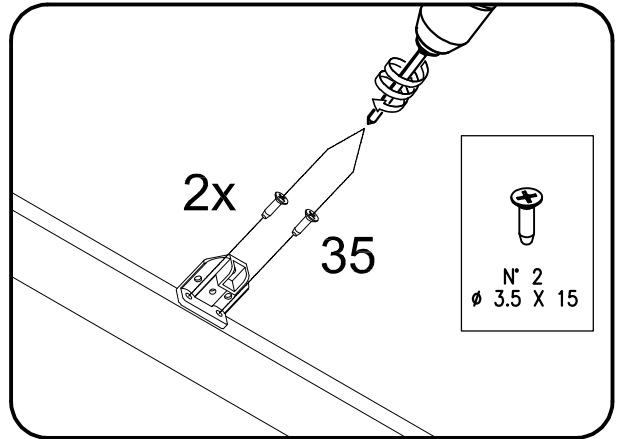
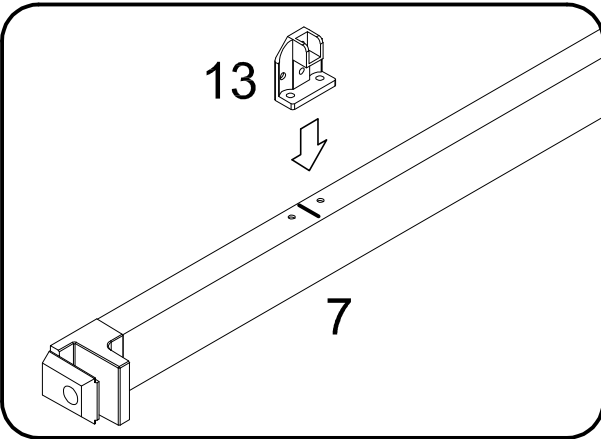
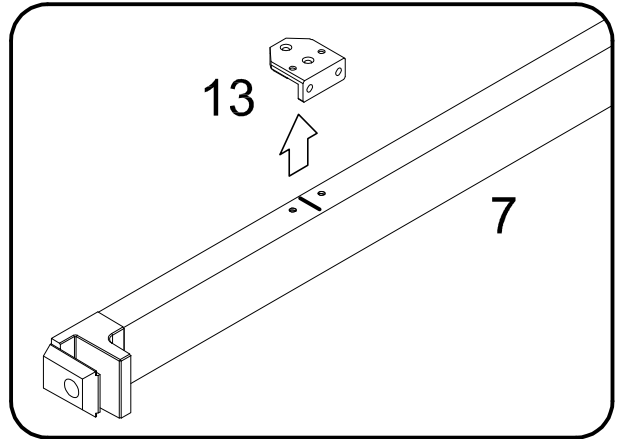
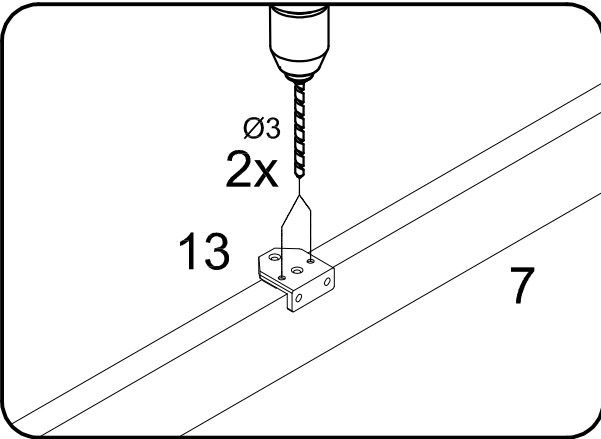
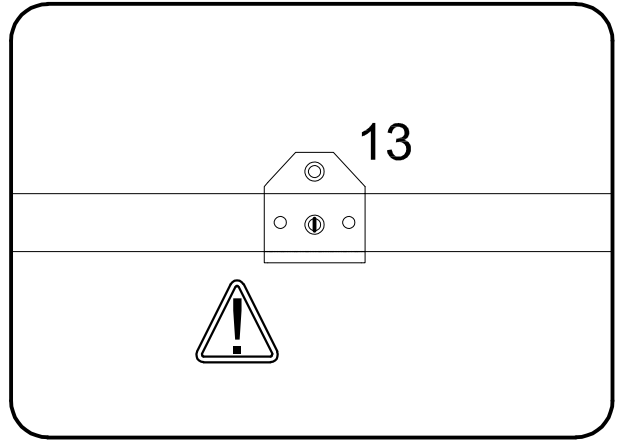
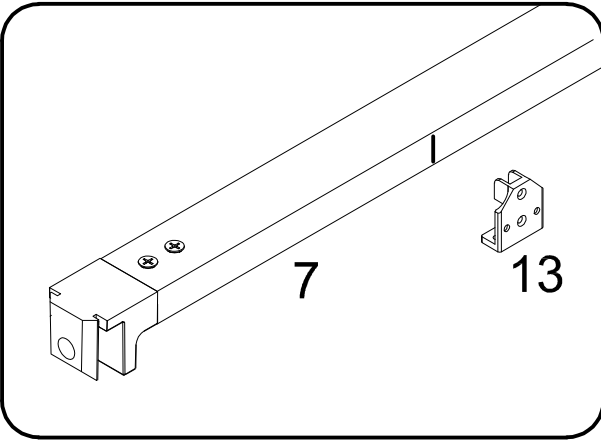

43

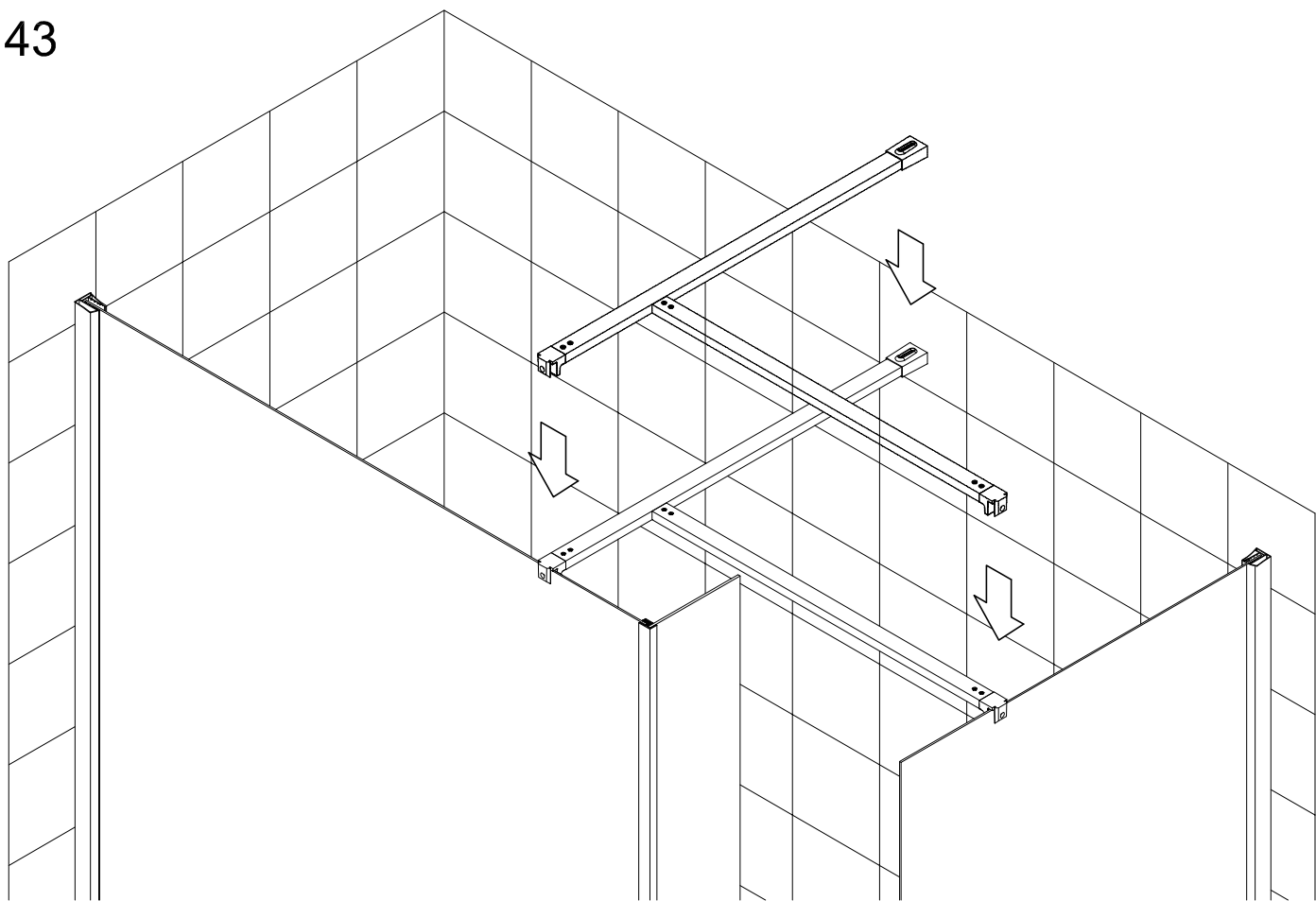

44

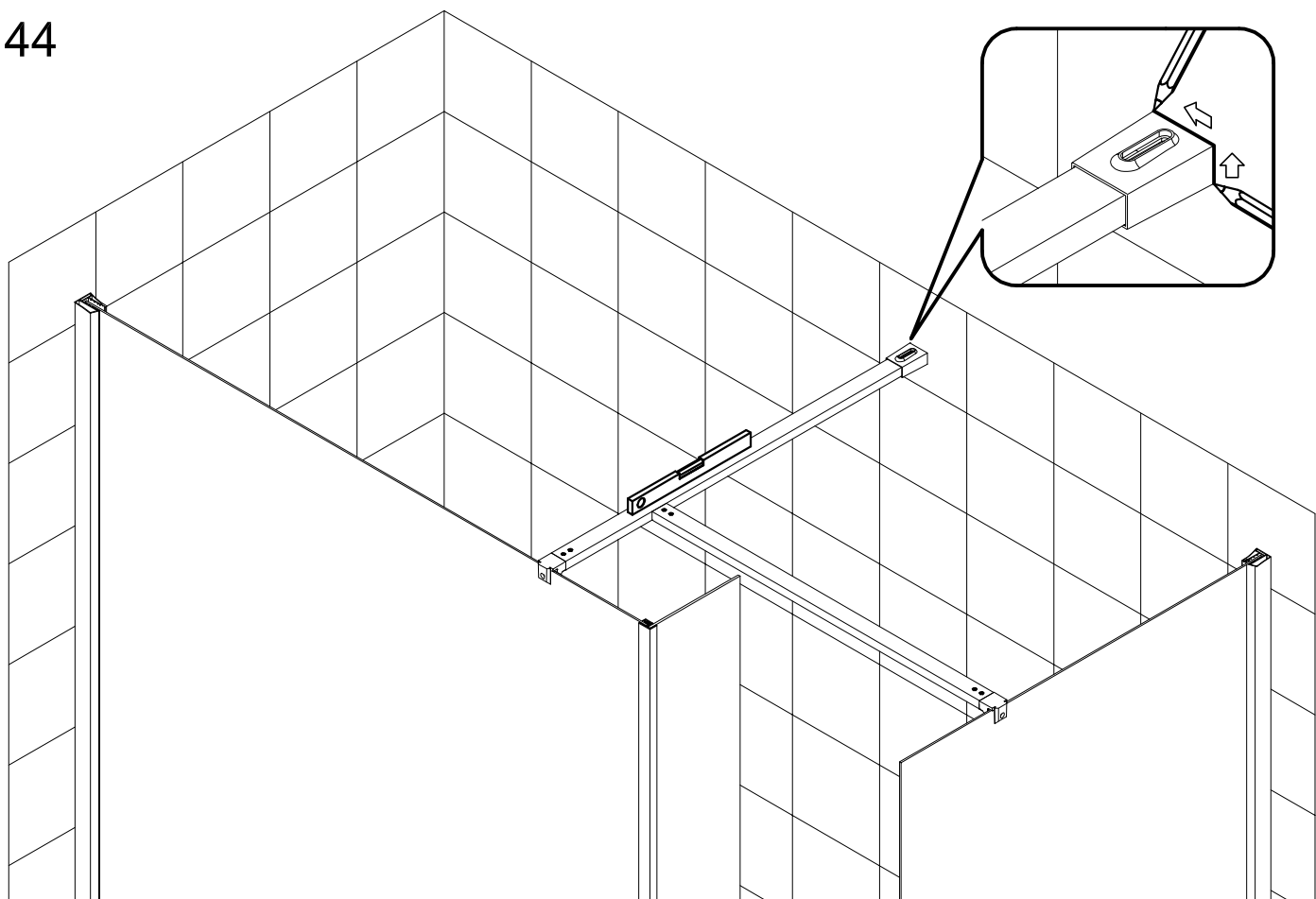

45

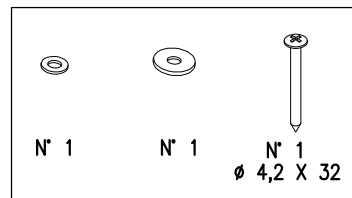
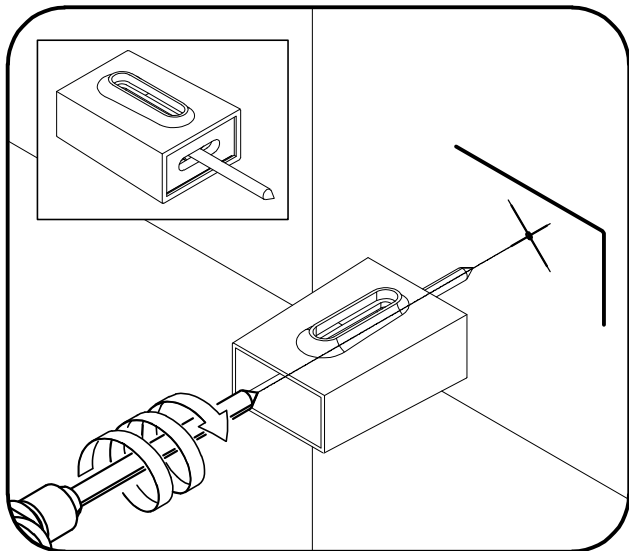
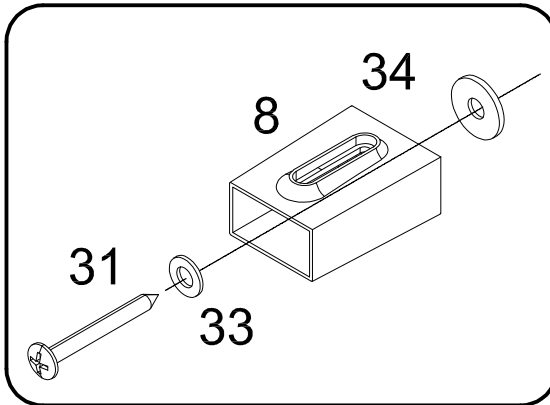
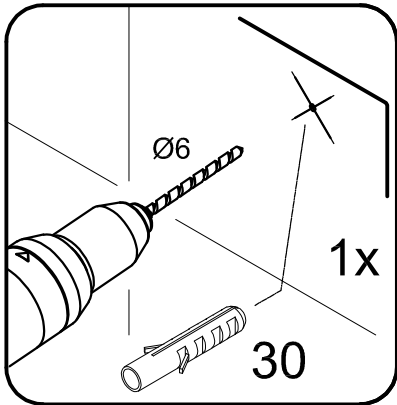
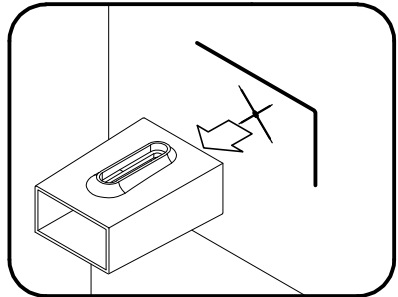
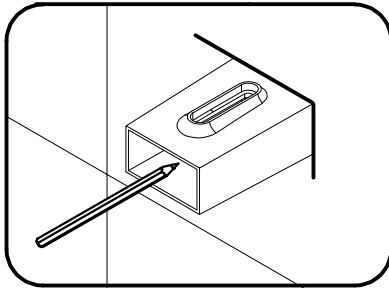
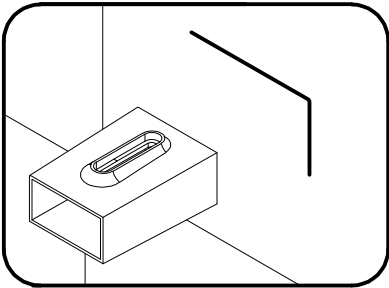
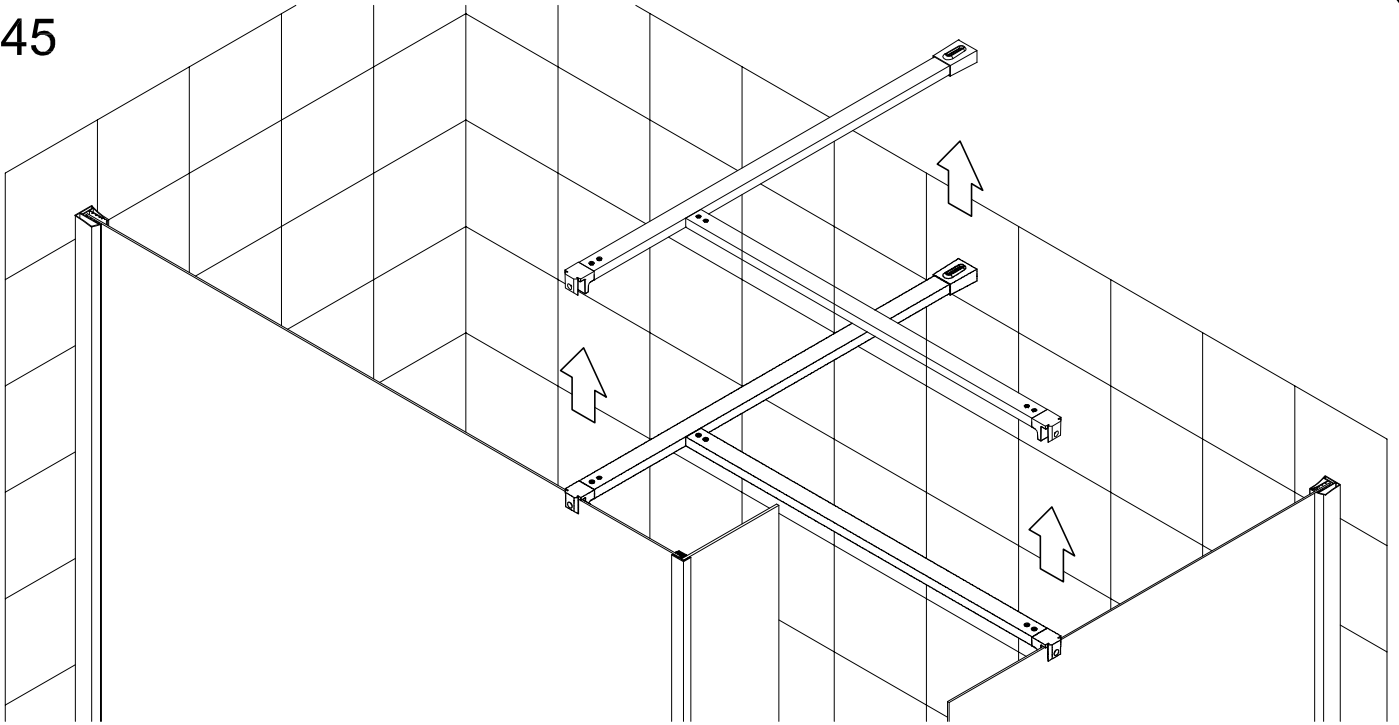

46

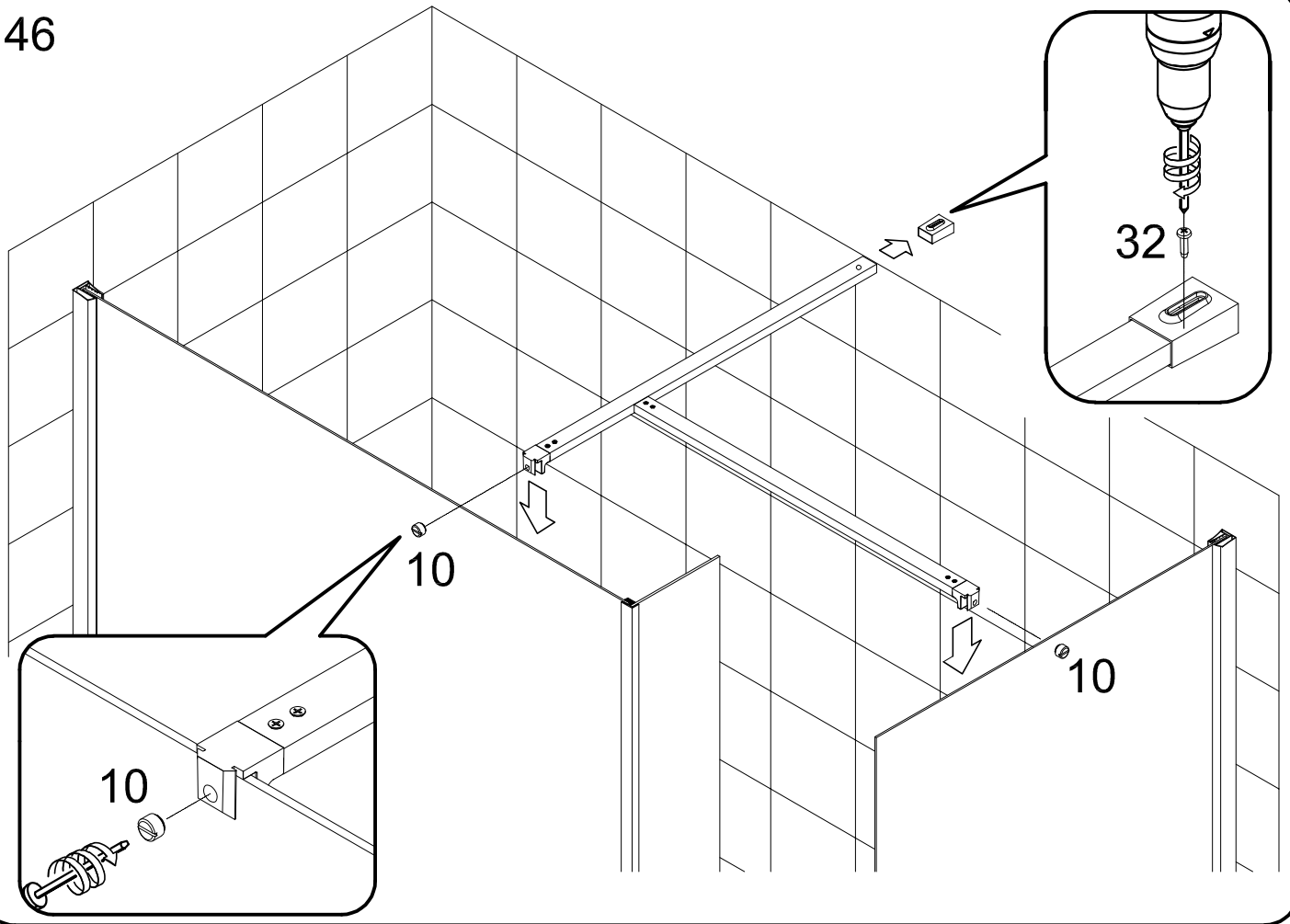

47

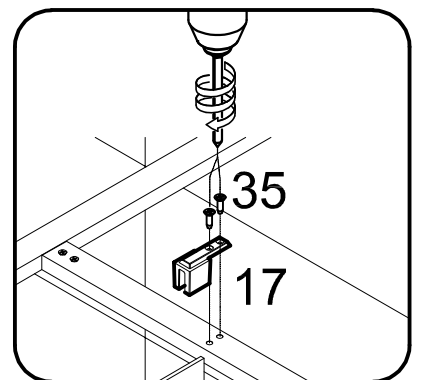
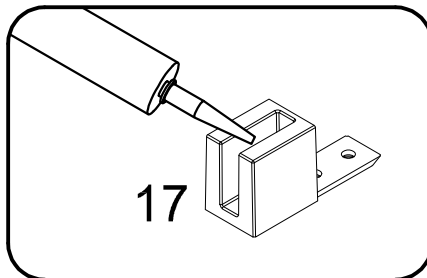
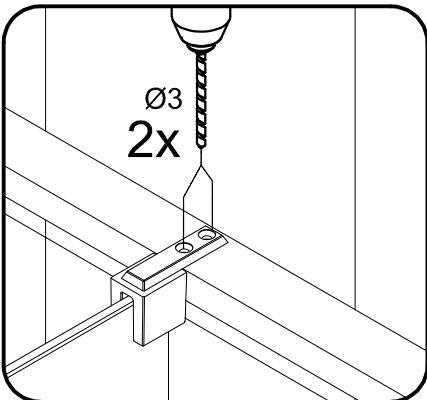
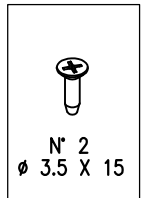
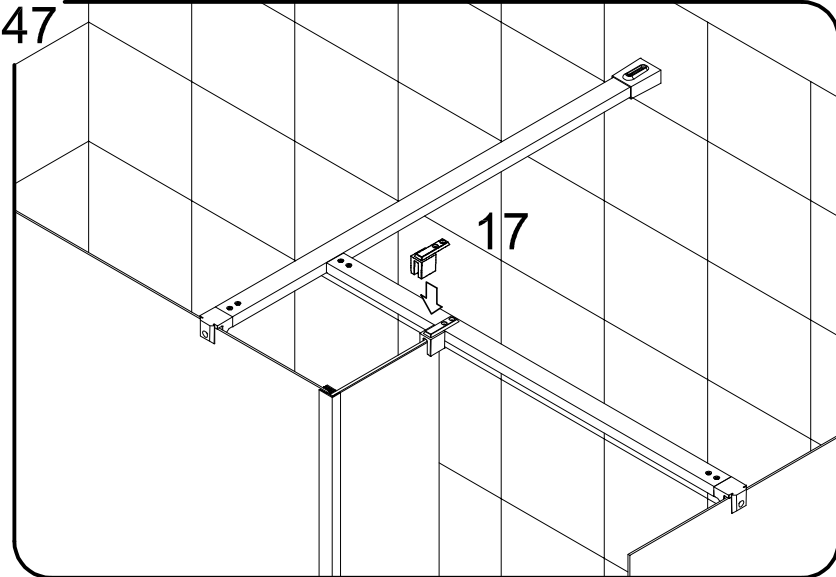

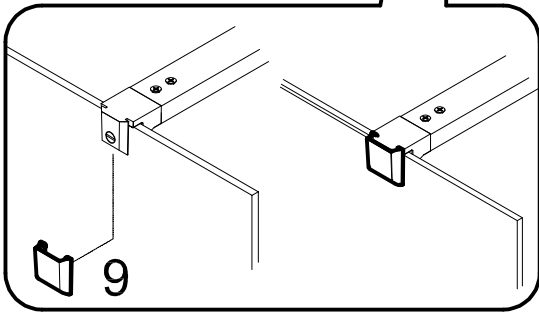
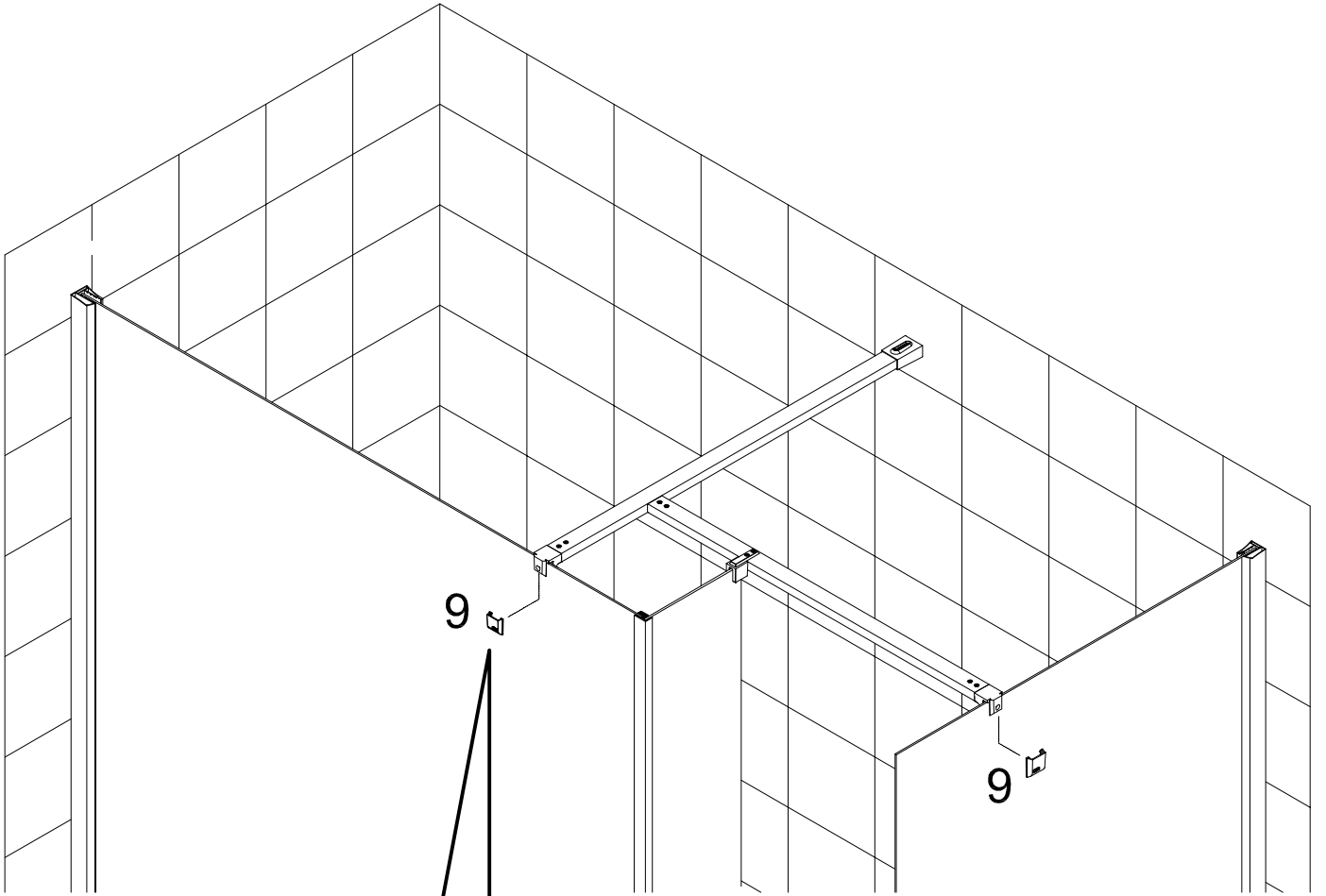



Pag. 1

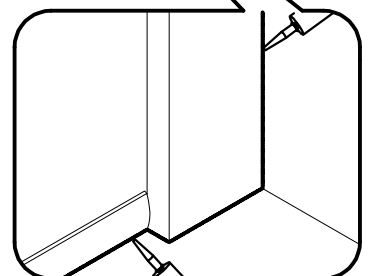
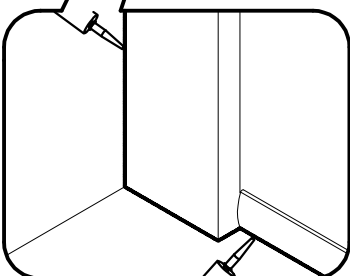
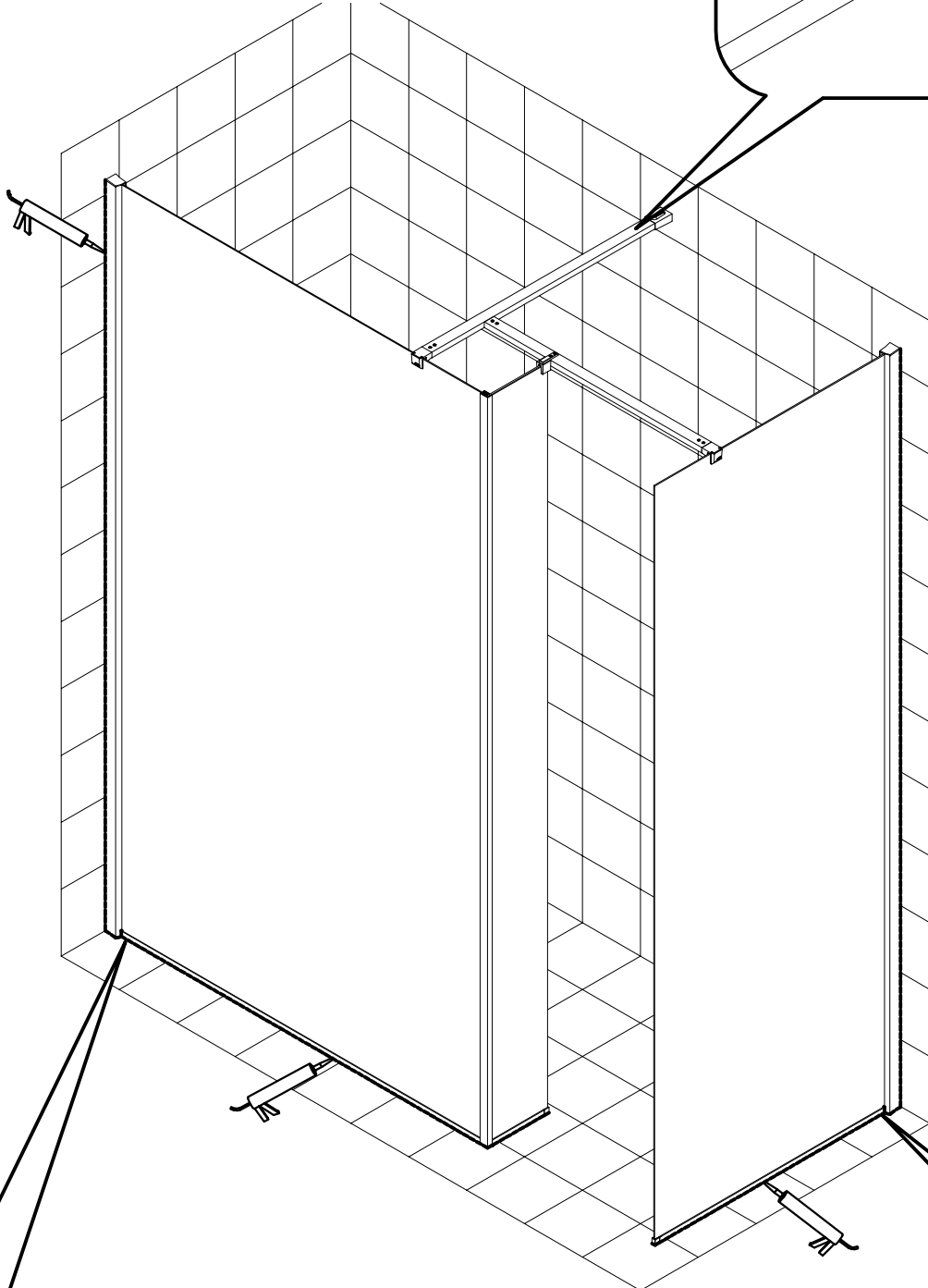
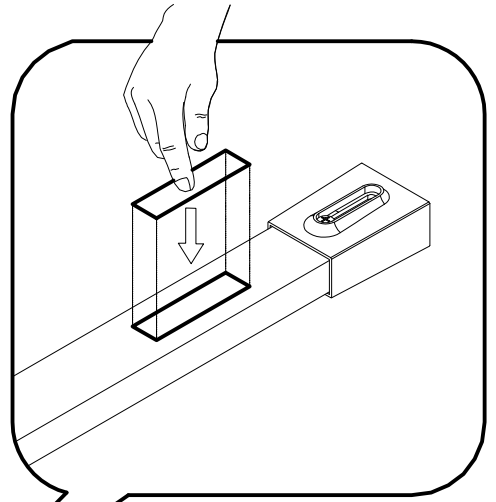
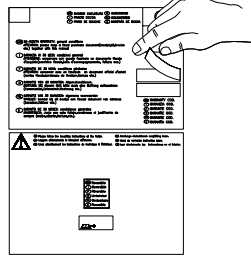

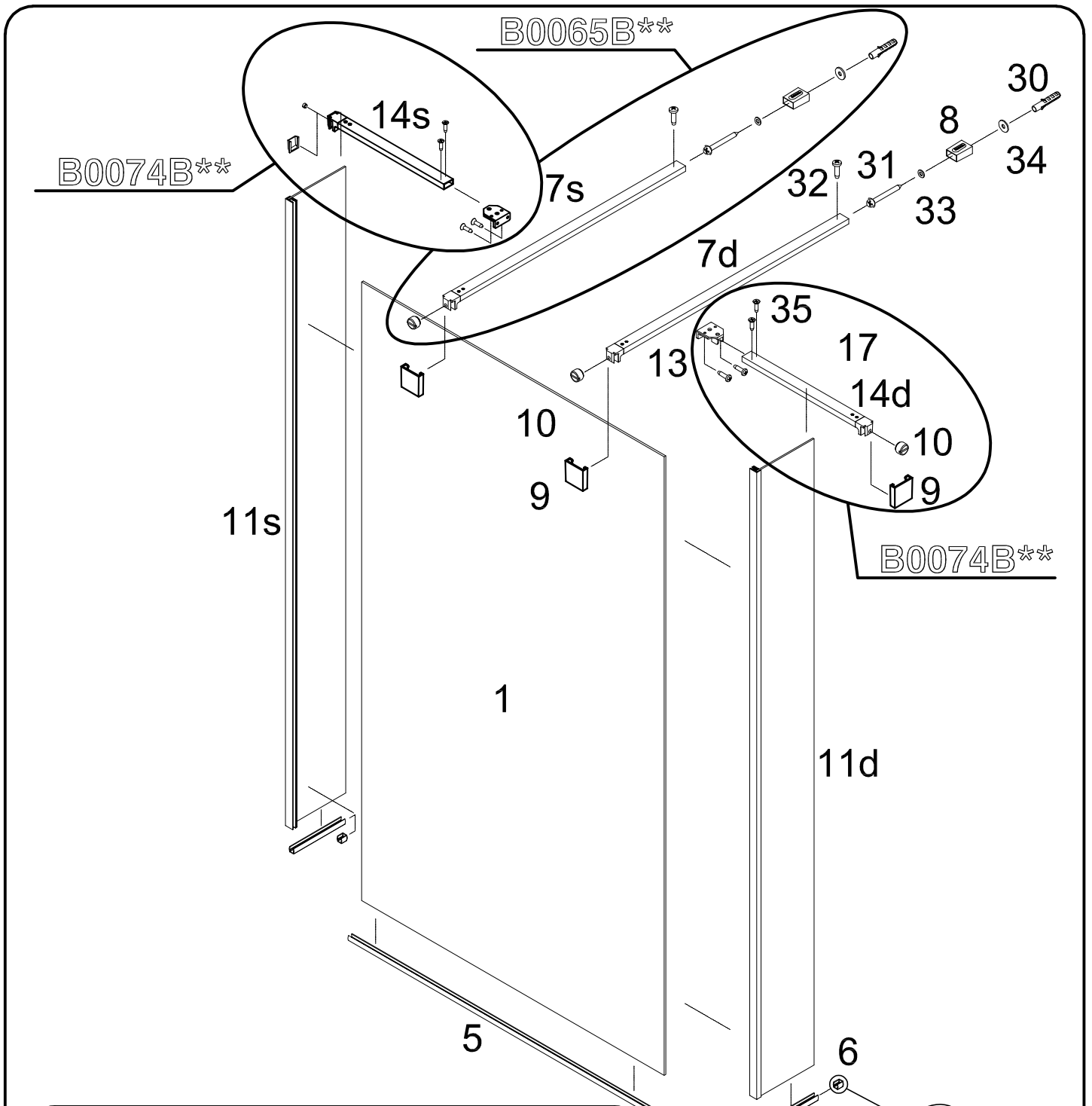

- | | | | | | |
|------------------|--------------------|--------------------|-----------|-----------|---------------------|
| 30 | 31 | 32 | 33 | 34 | 35 |
| | | | | | |
| N° 2
∅ 6 X 30 | N° 2
∅ 4,2 X 32 | N° 2
∅ 3,5 X 13 | N° 2 | N° 2 | N° 12
∅ 3,5 X 13 |

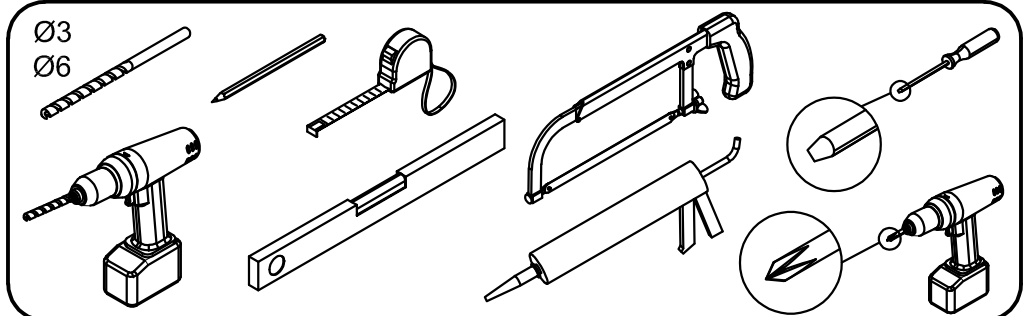
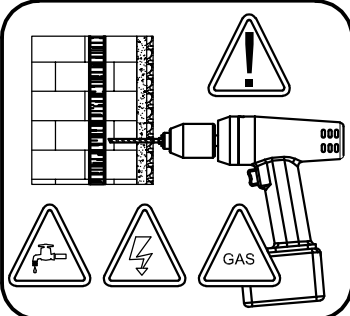

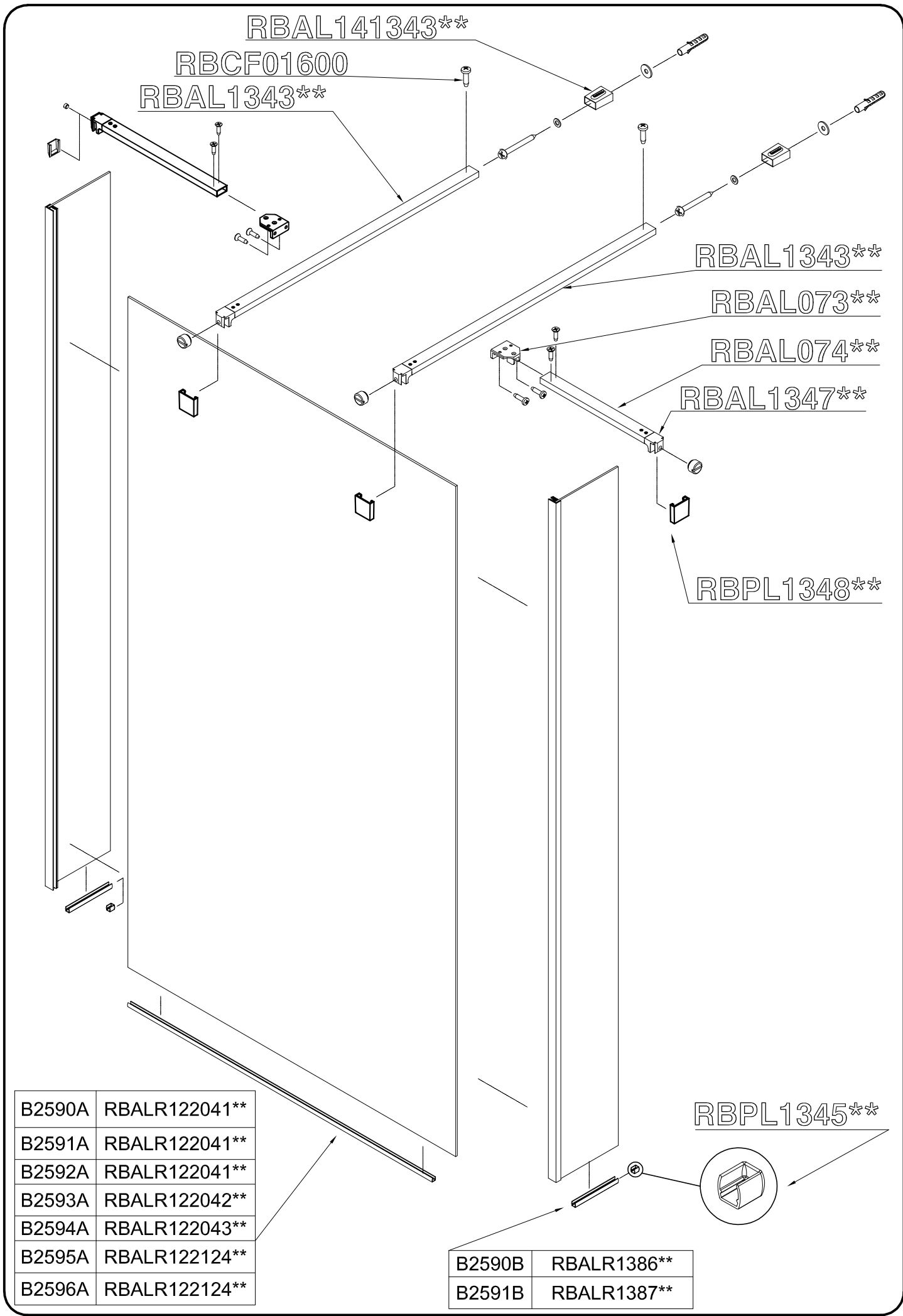

RBAL141343**

RBCF01600

RBAL1343**

RBAL1343**

RBAL073**

RBAL074**

RBAL1347**

RBPL1348**

RBPL1345**

B2590A	RBALR122041**
B2591A	RBALR122041**
B2592A	RBALR122041**
B2593A	RBALR122042**
B2594A	RBALR122043**
B2595A	RBALR122124**
B2596A	RBALR122124**

B2590B	RBALR1386**
B2591B	RBALR1387**

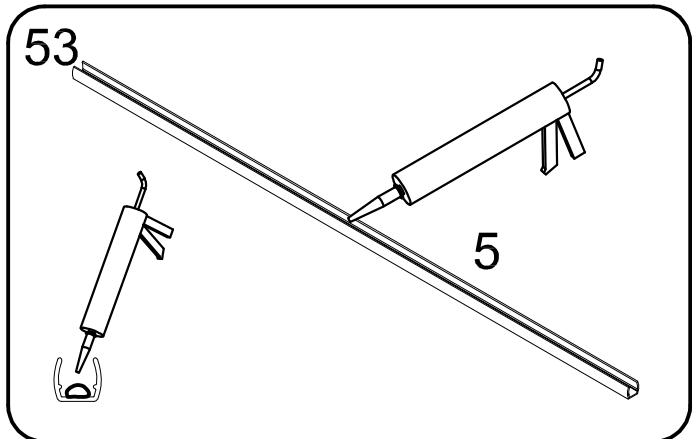
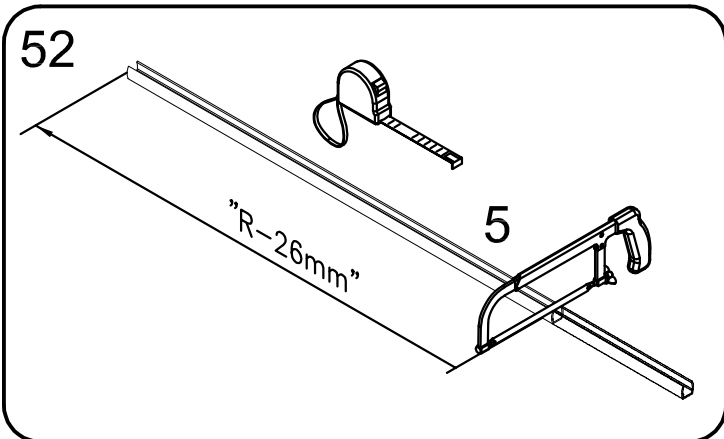
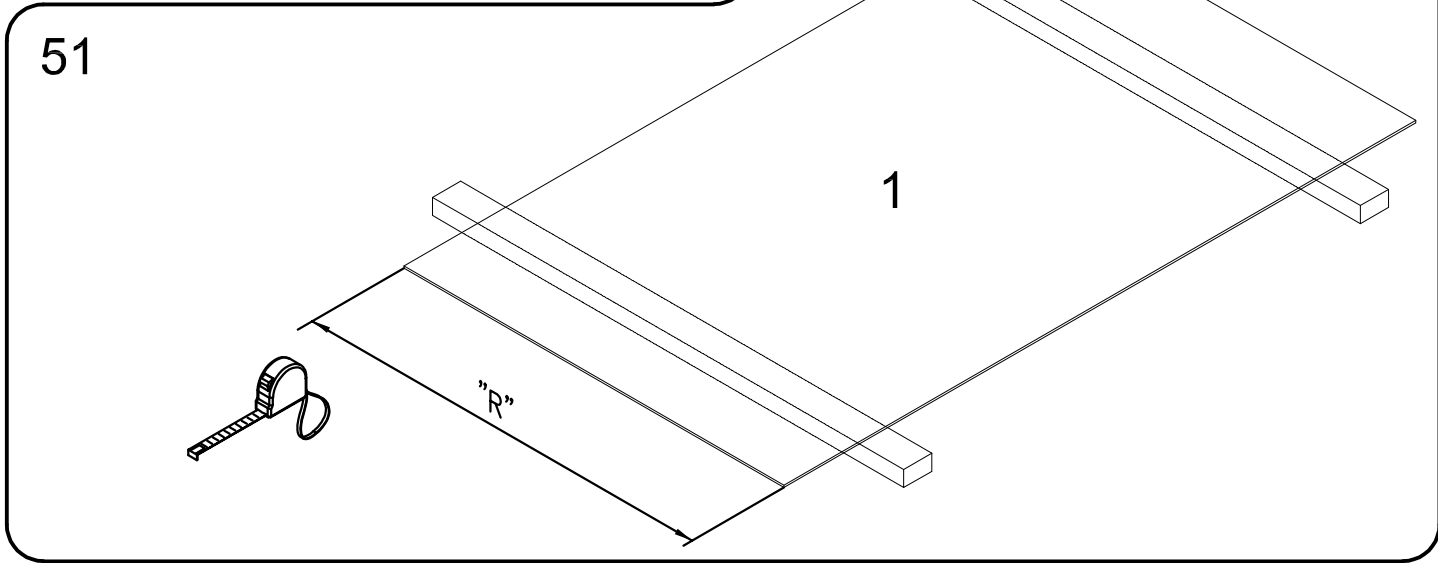
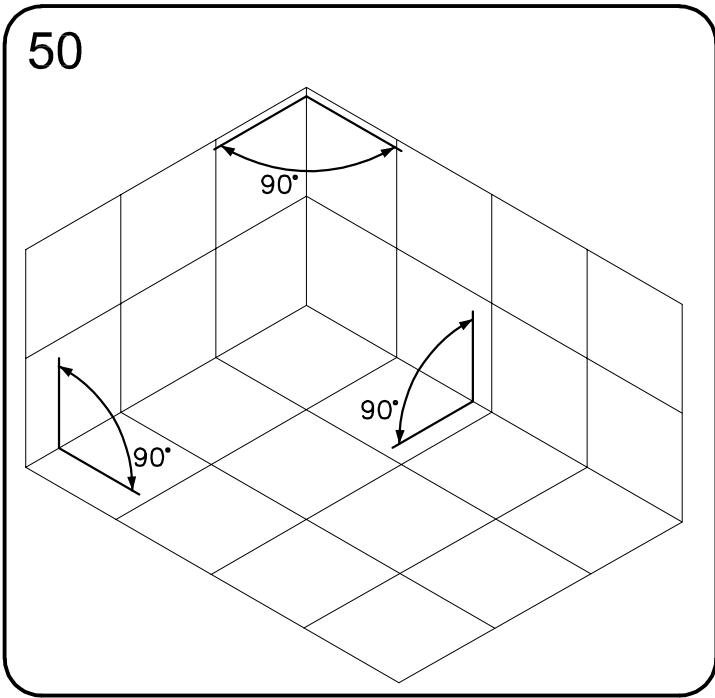
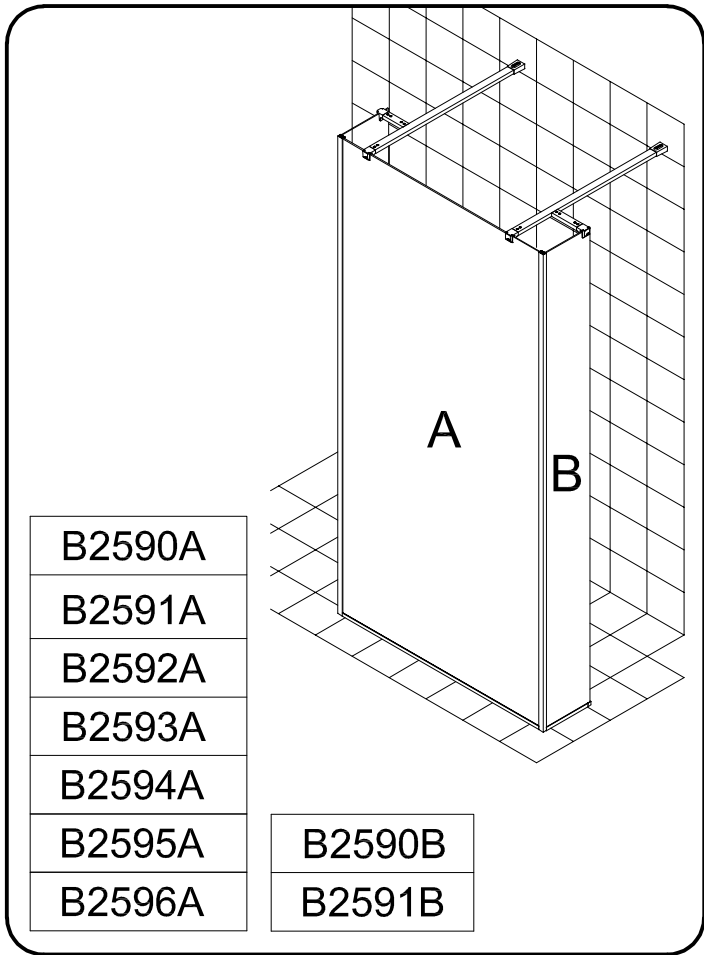

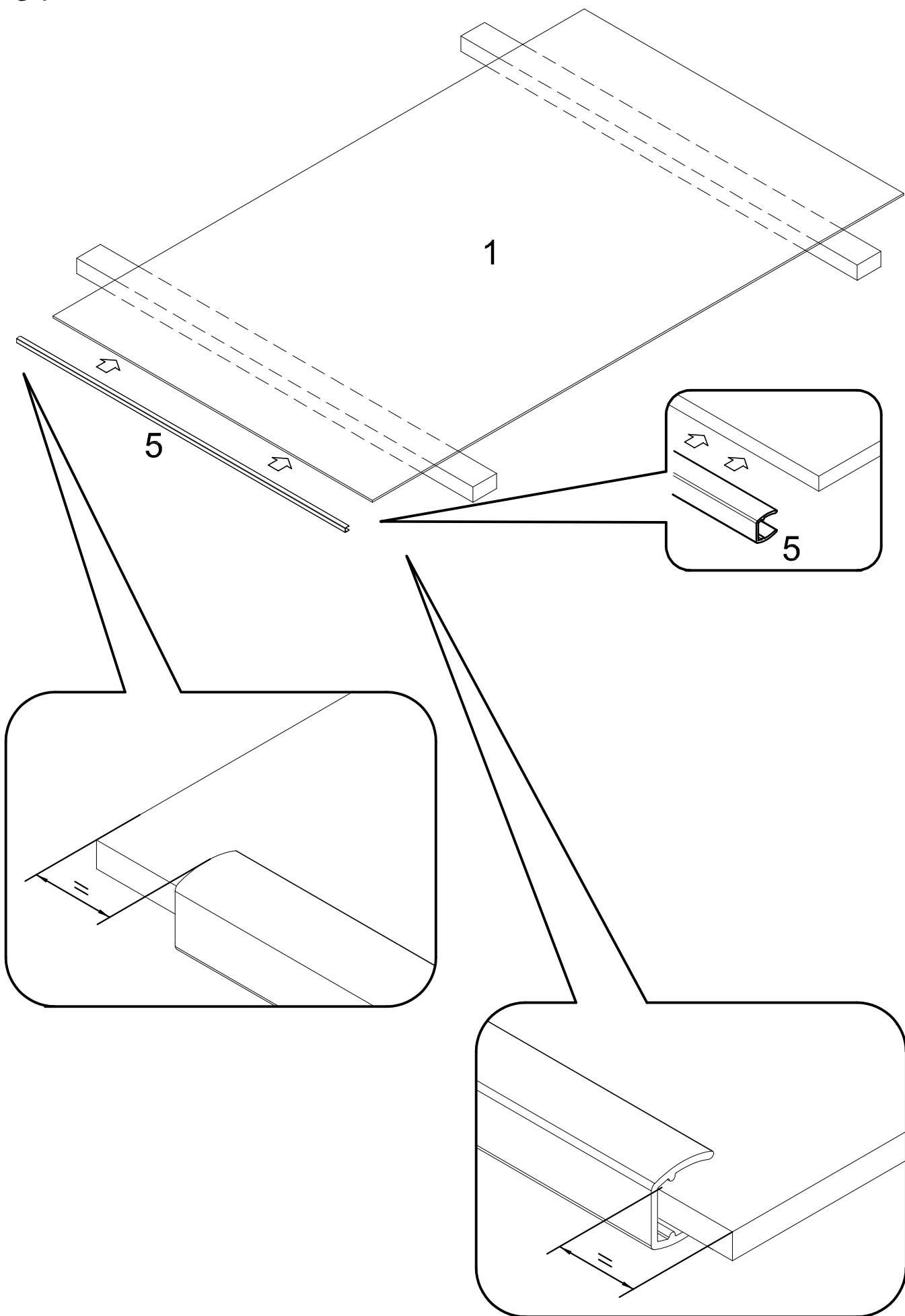

55

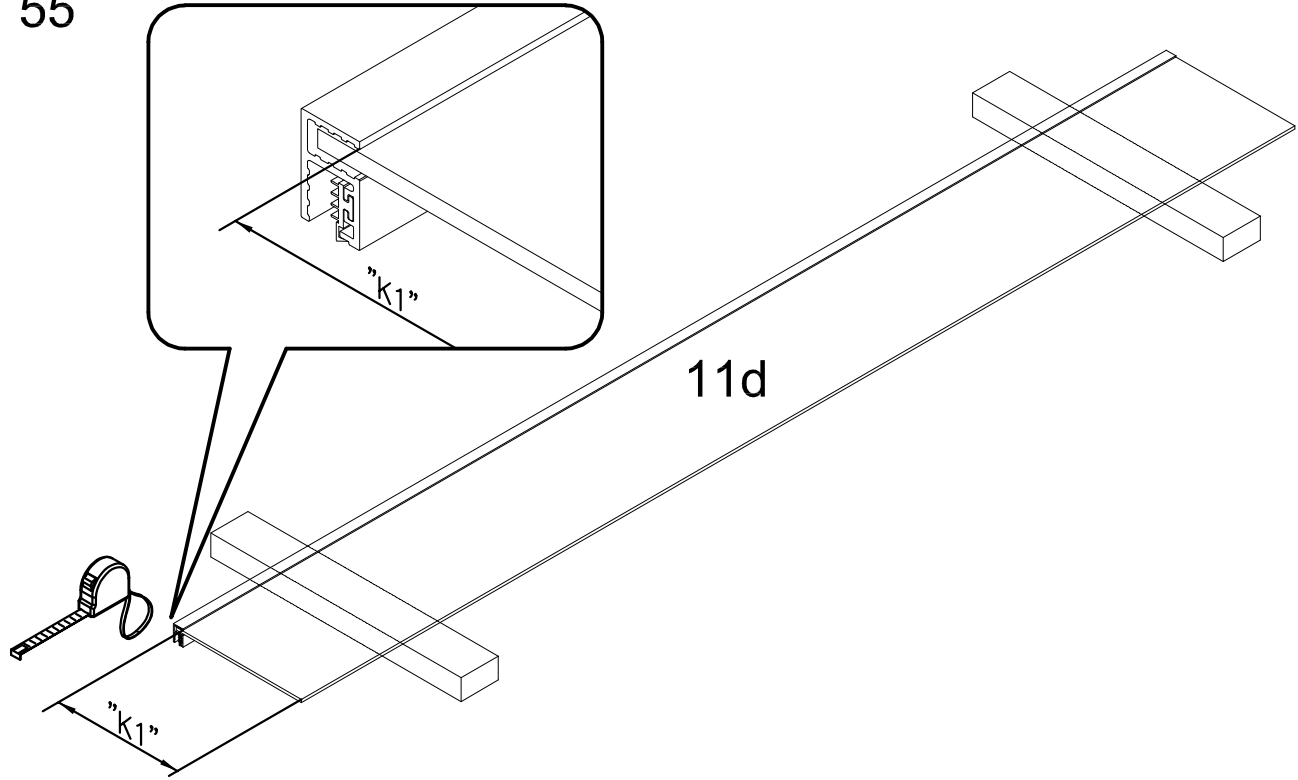

56

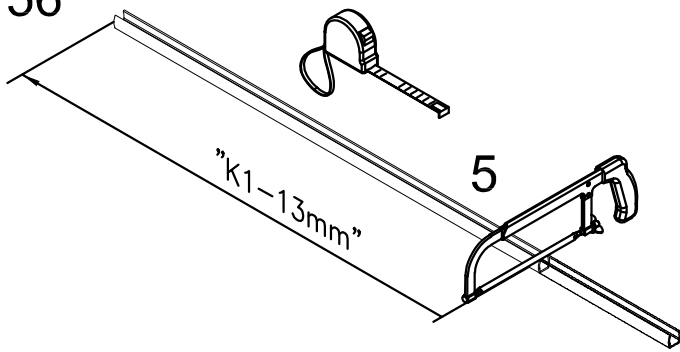

57

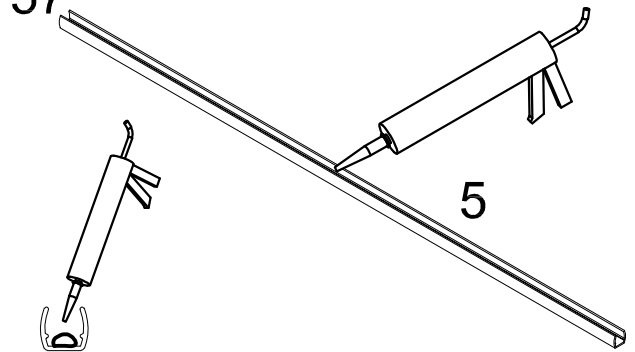

58

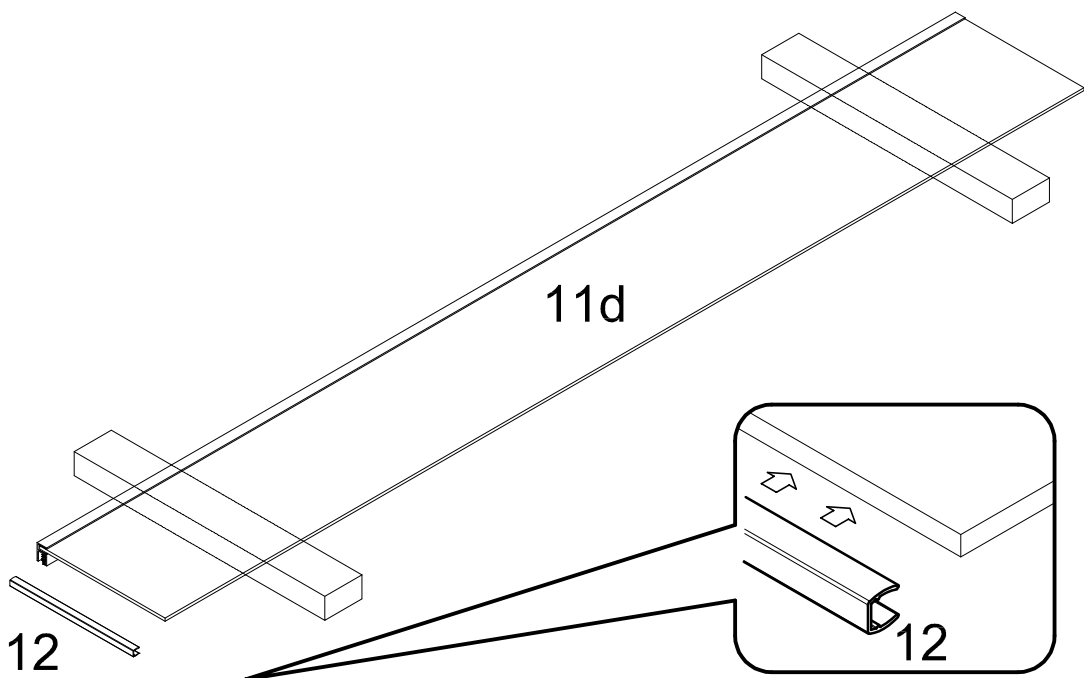

59

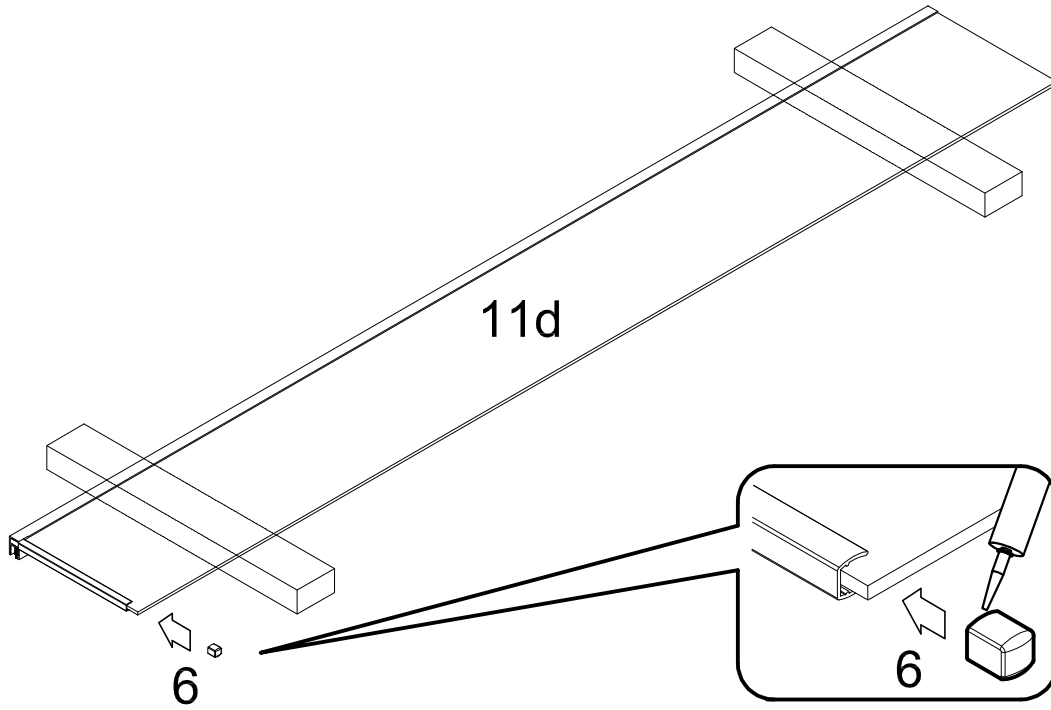

60

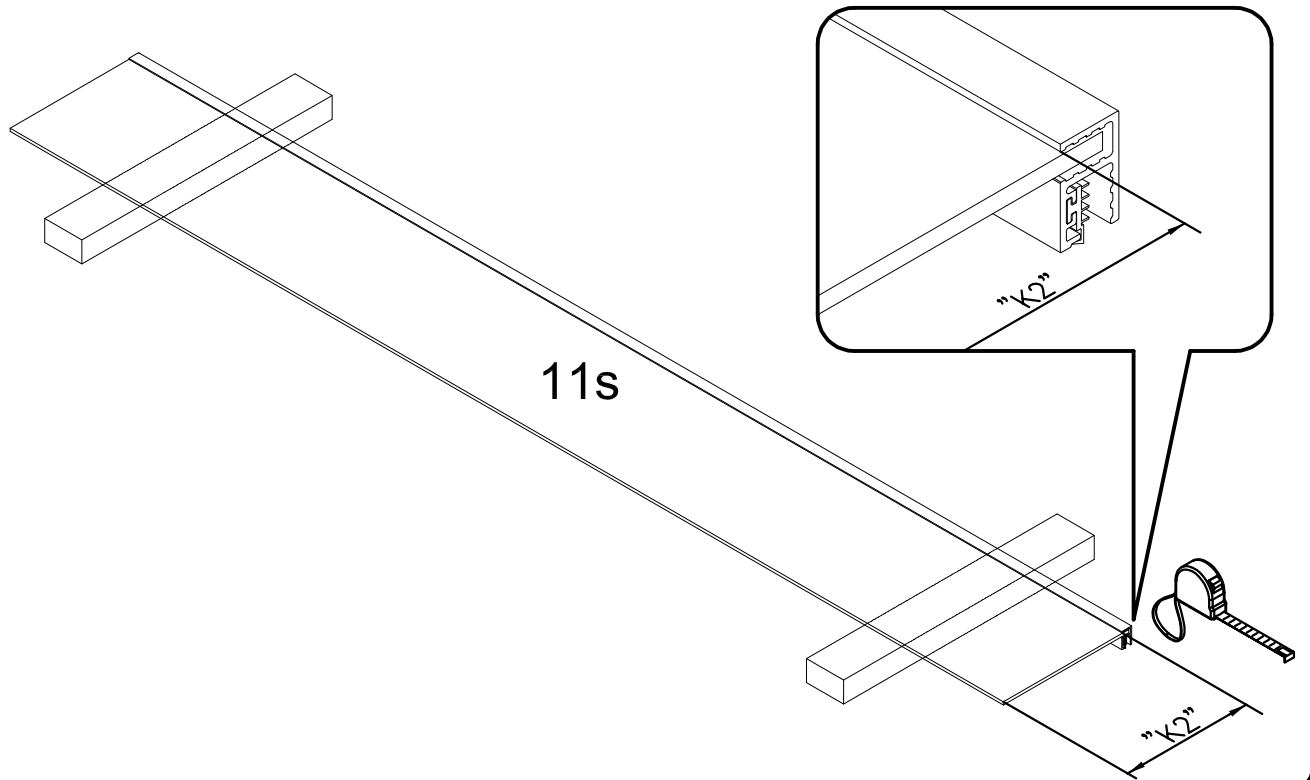

61

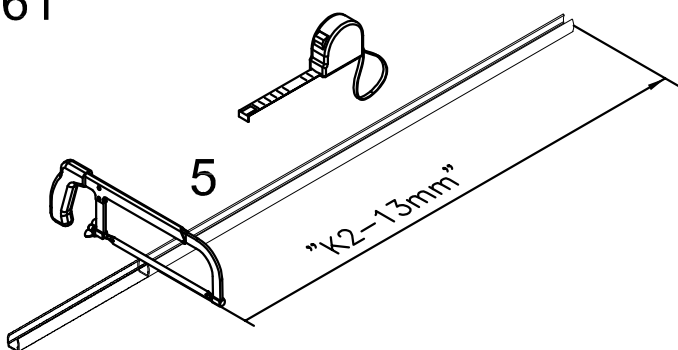

62

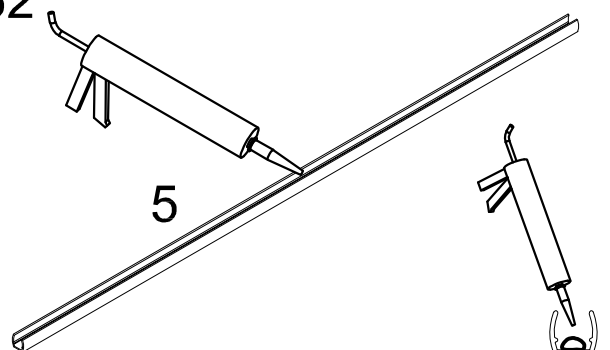

63

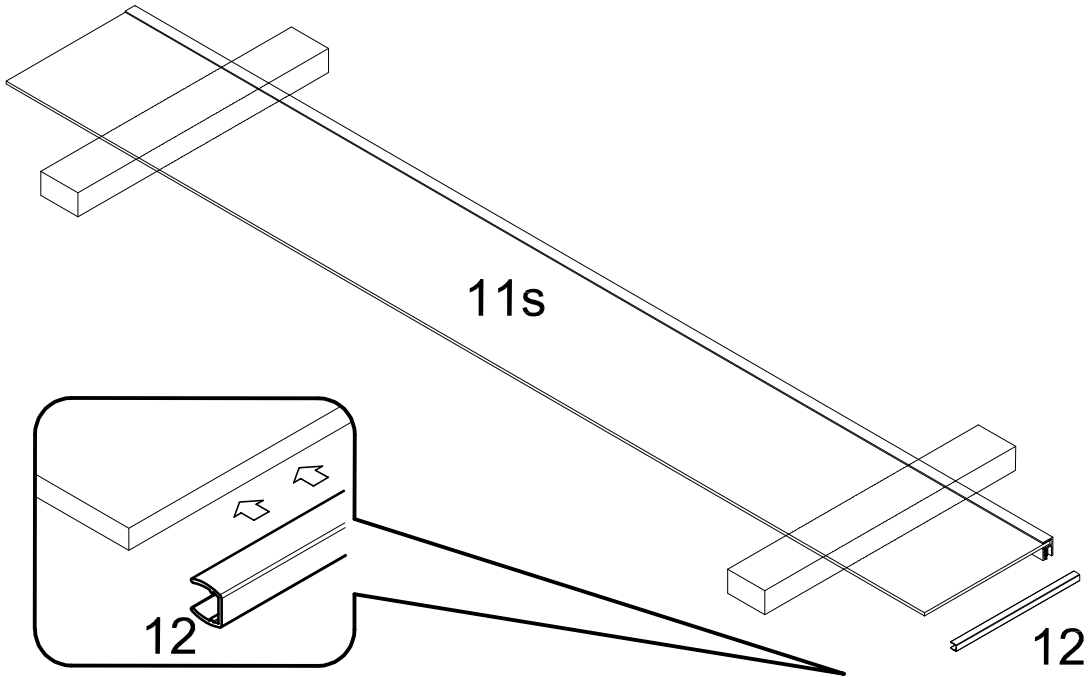

64

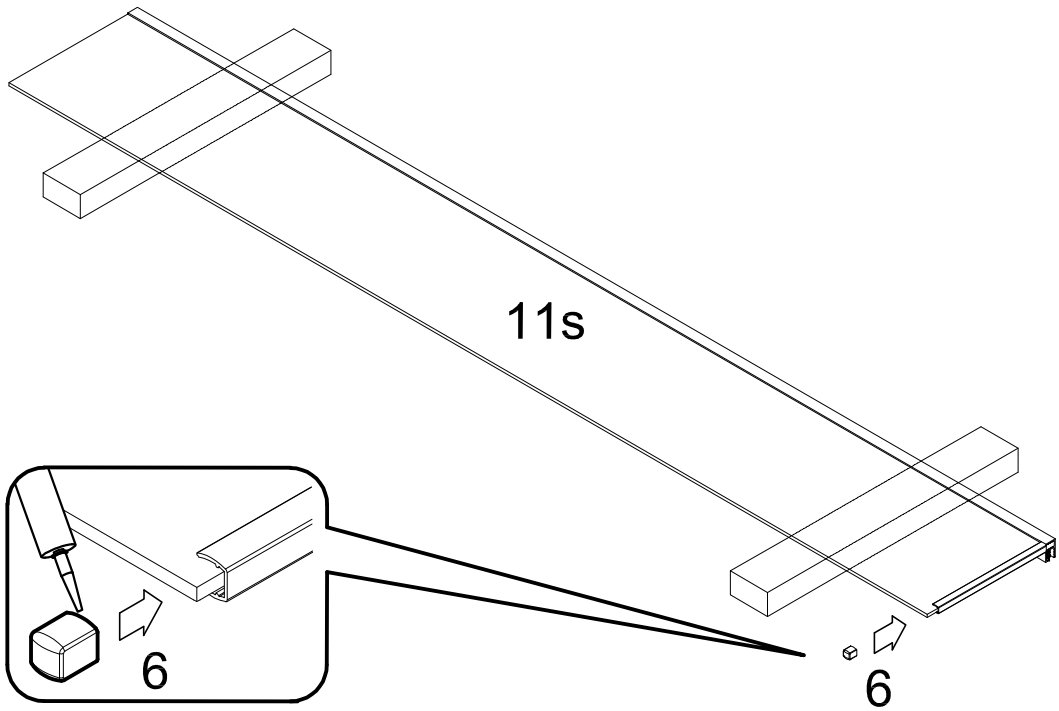

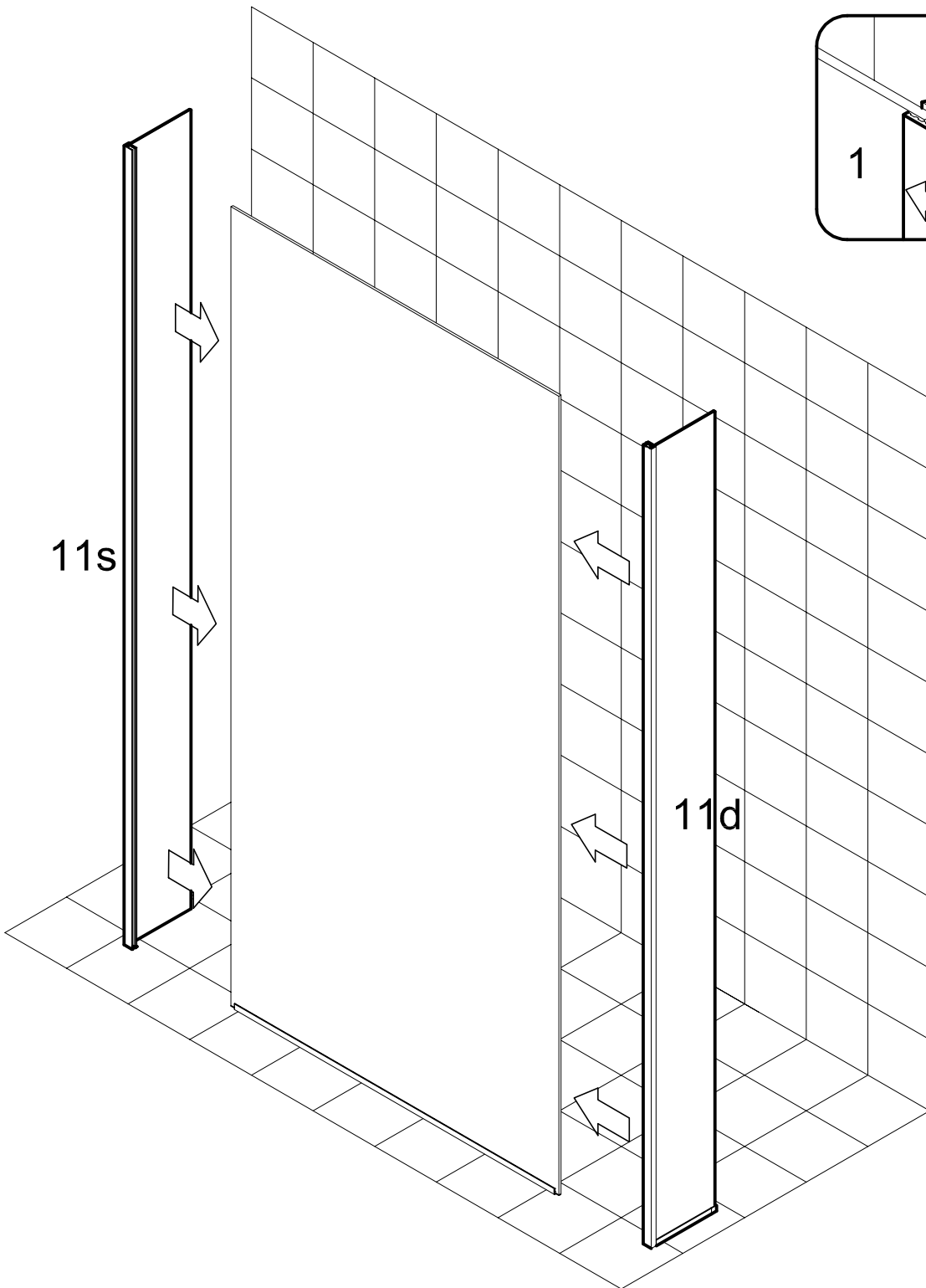
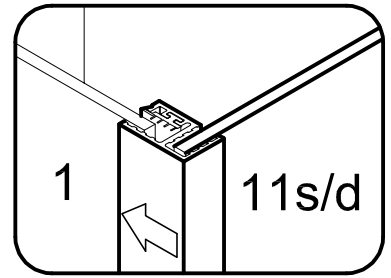
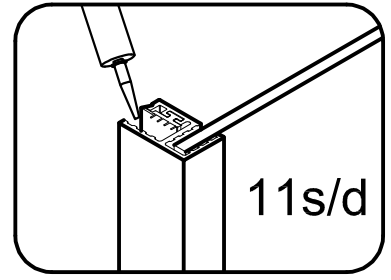

66

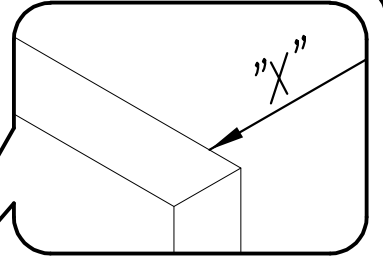
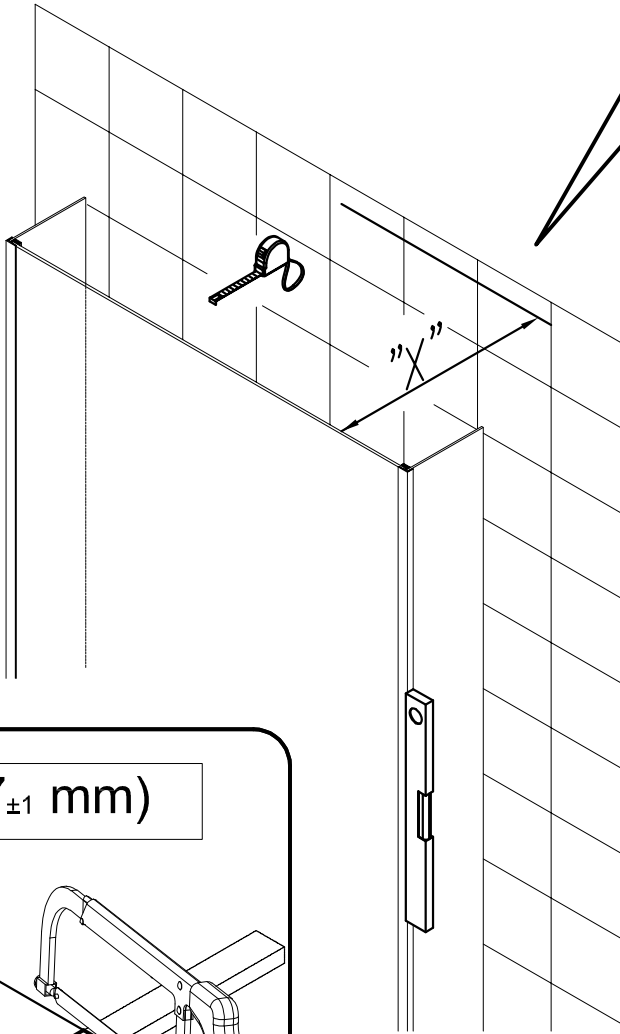

$"Z" = (X - 17_{\pm 1} \text{ mm})$

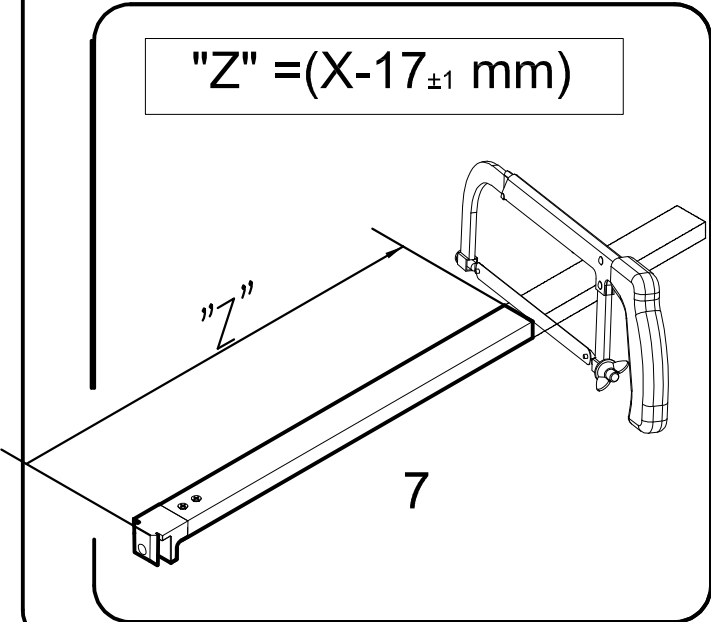

"X" max = 1200 mm

67

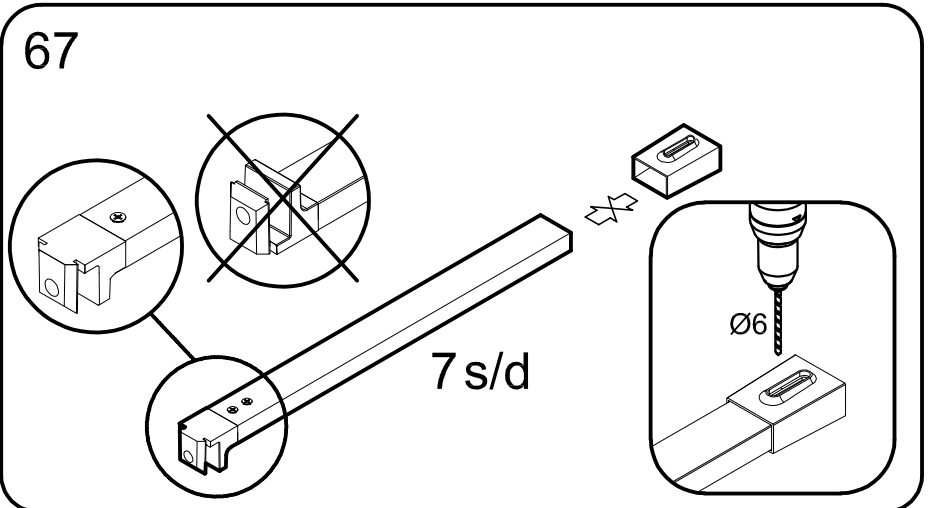
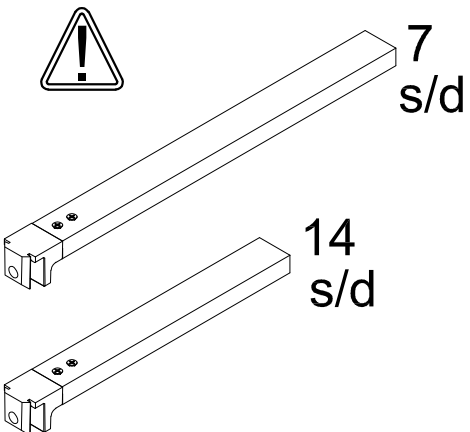

68

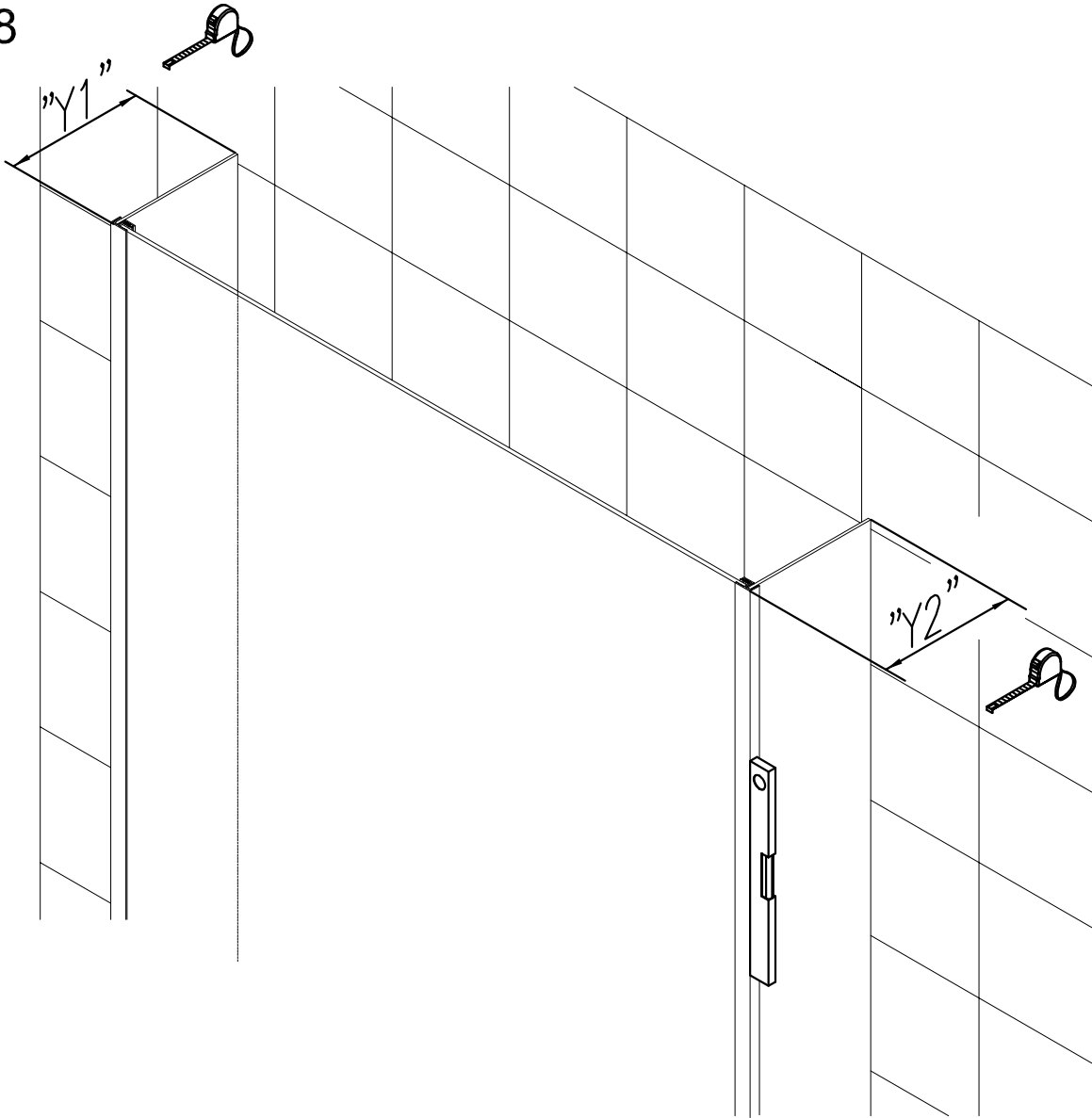

69

"H1" = (Y1 + 20 mm)

"H2" = (Y2 + 20 mm)

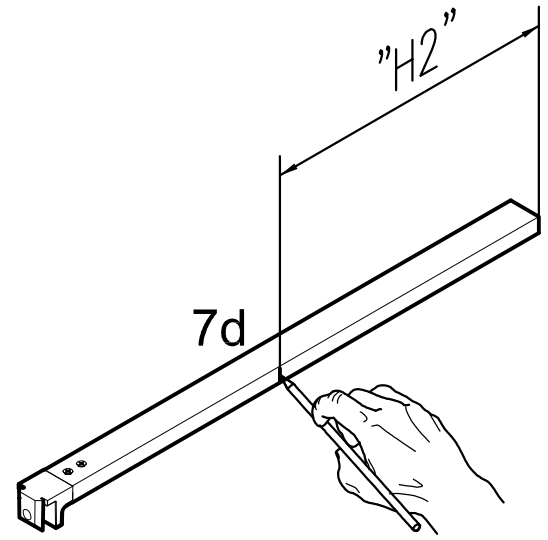
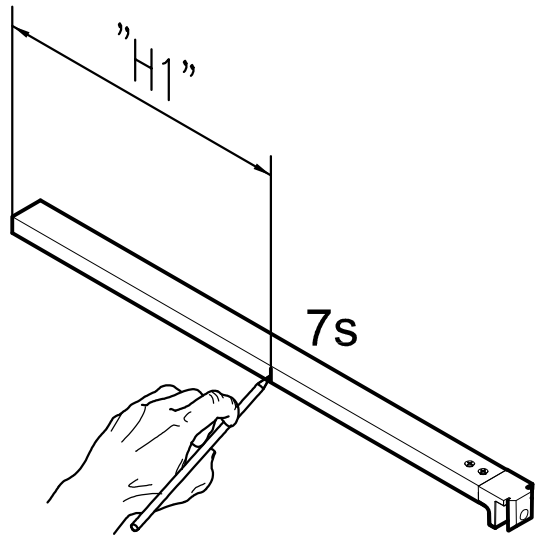

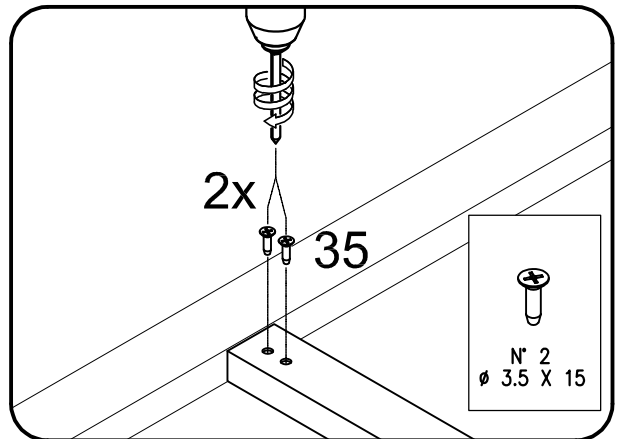
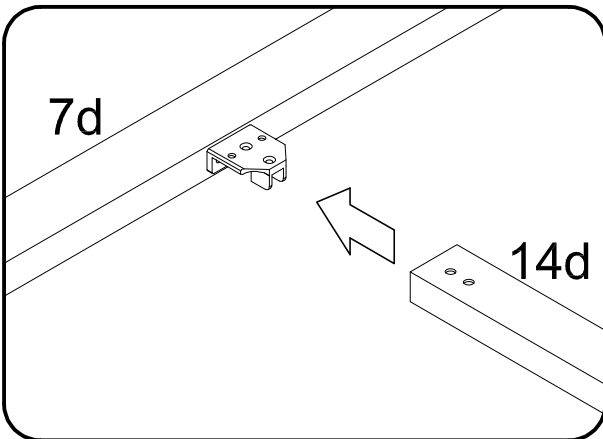
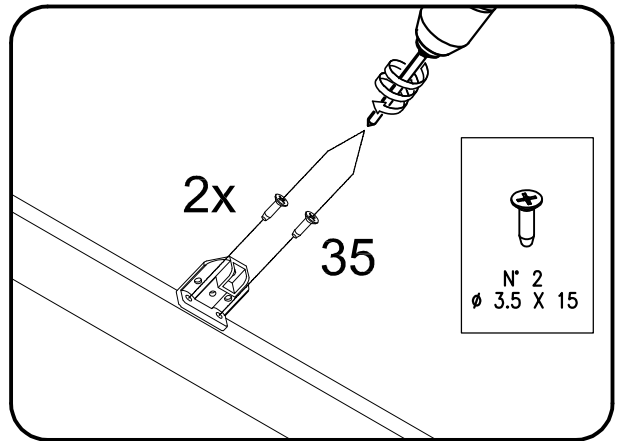
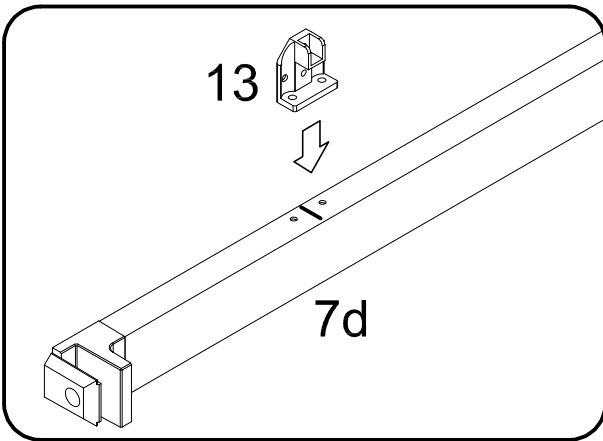
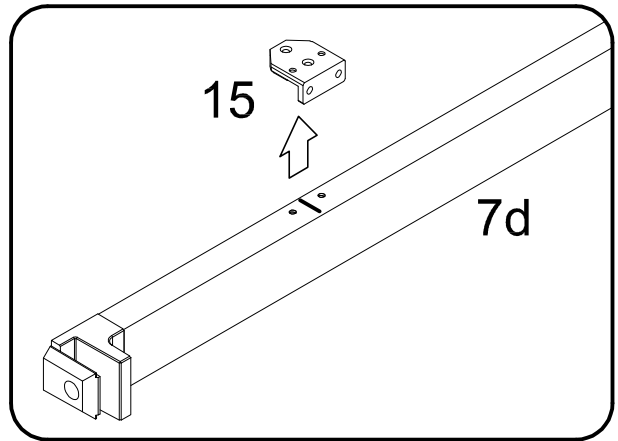
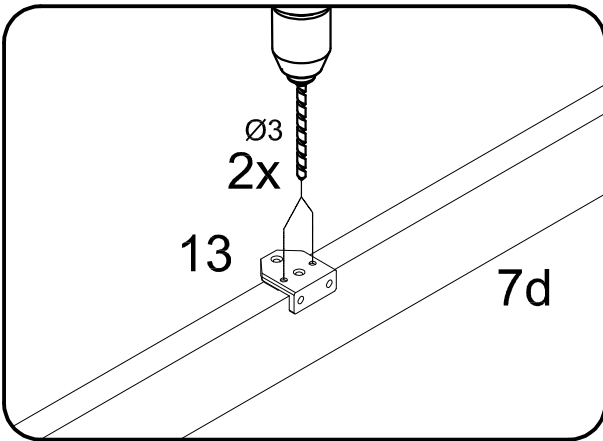
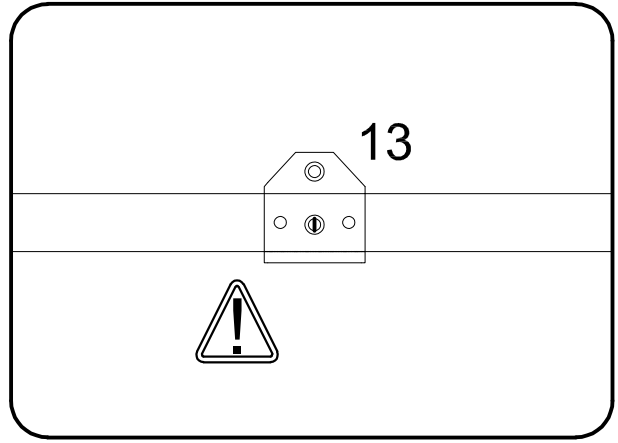
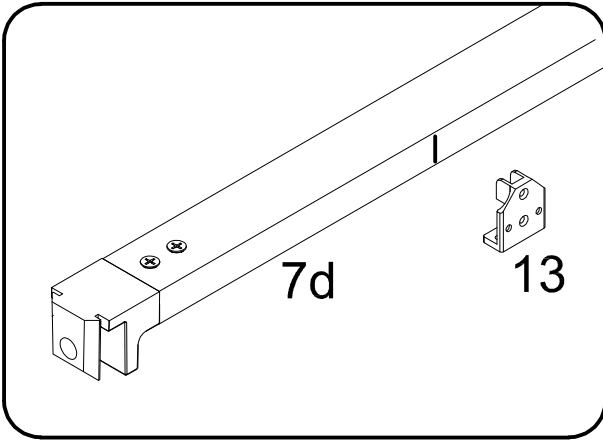

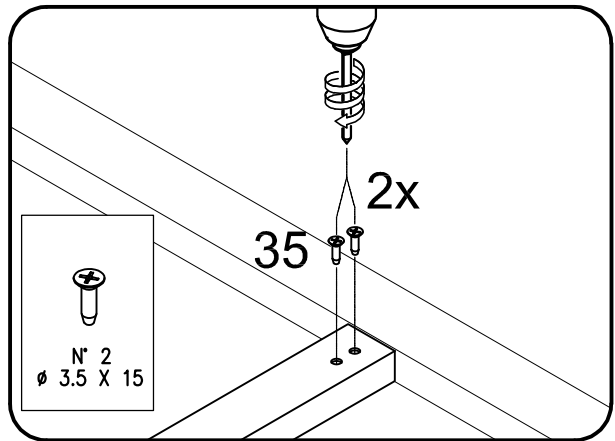
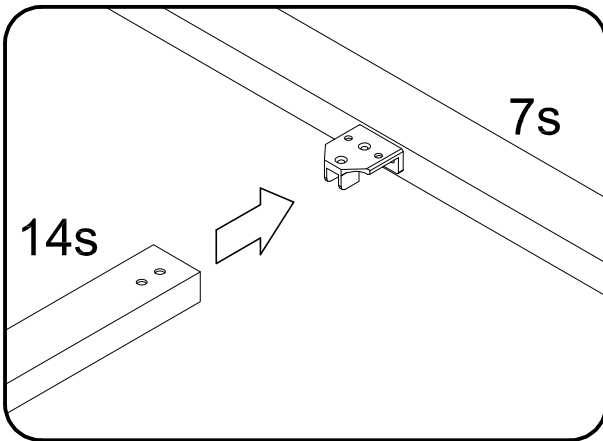
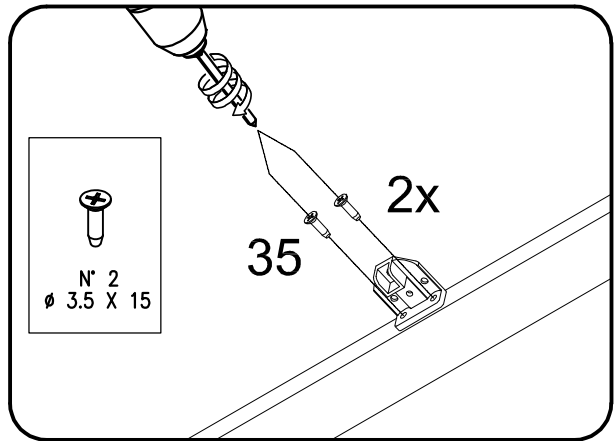
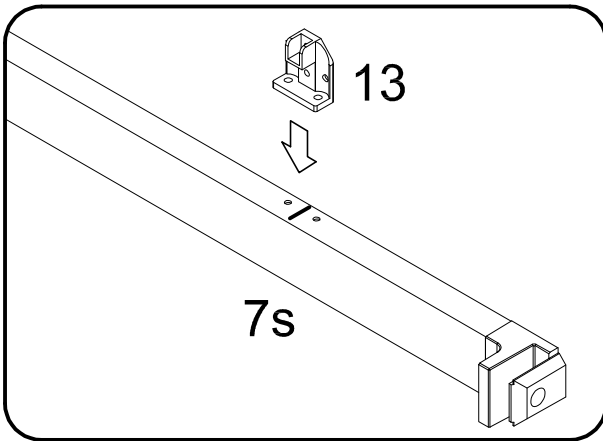
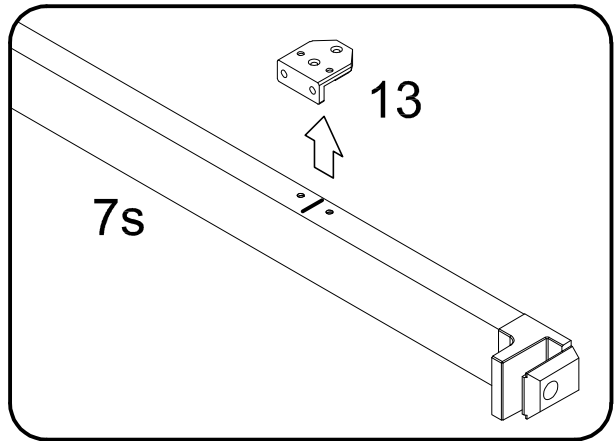
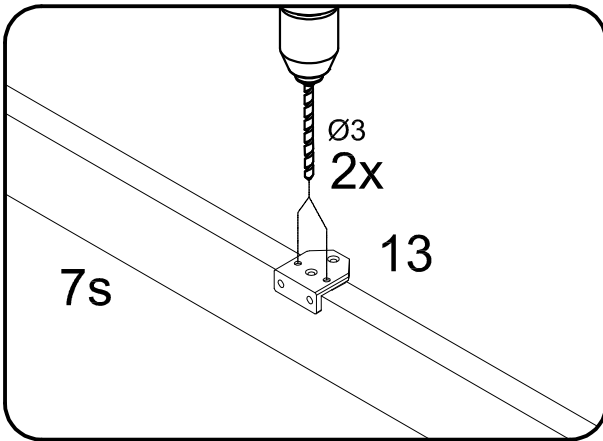
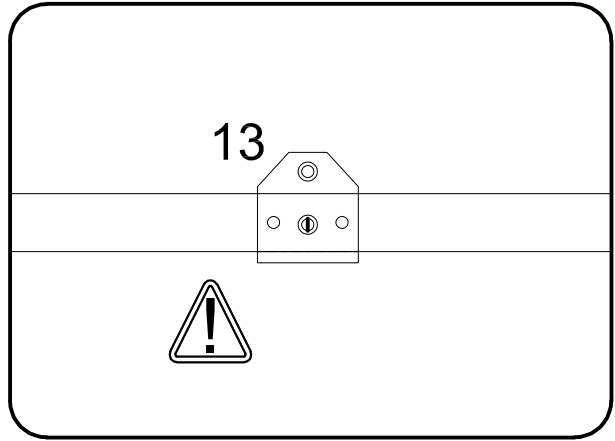
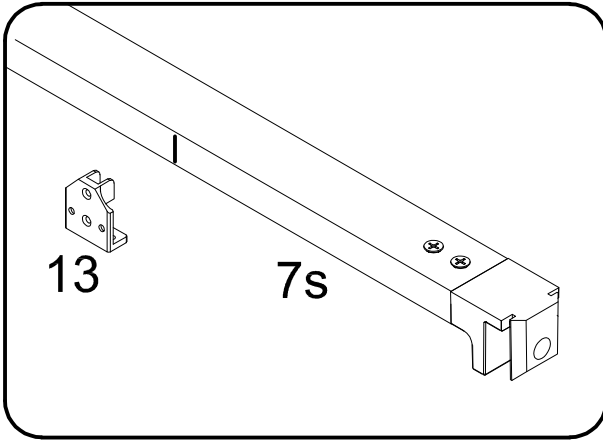

72

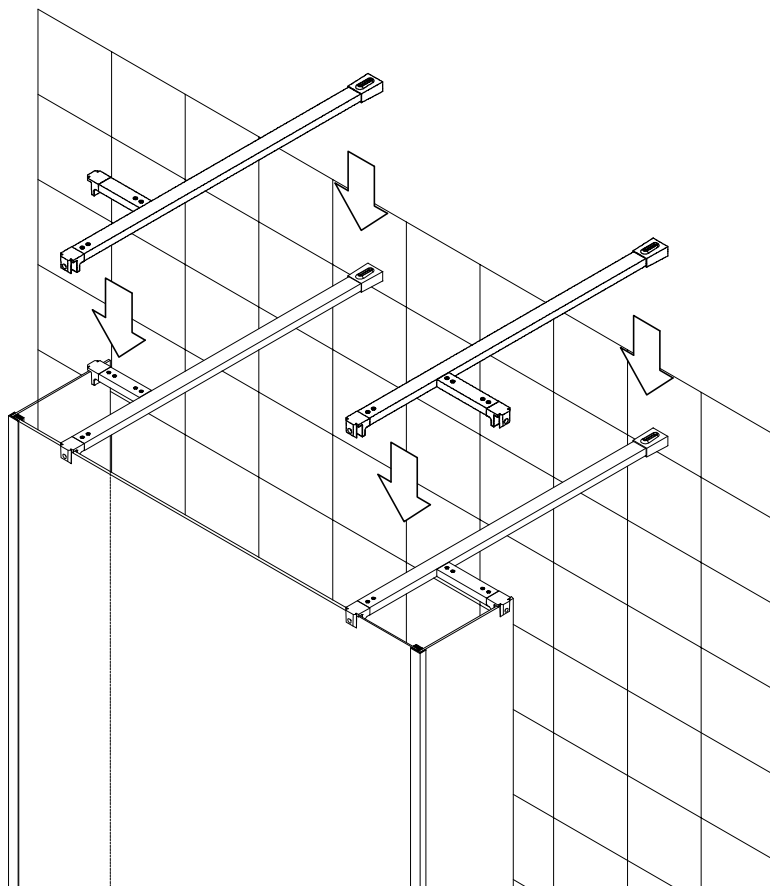

73

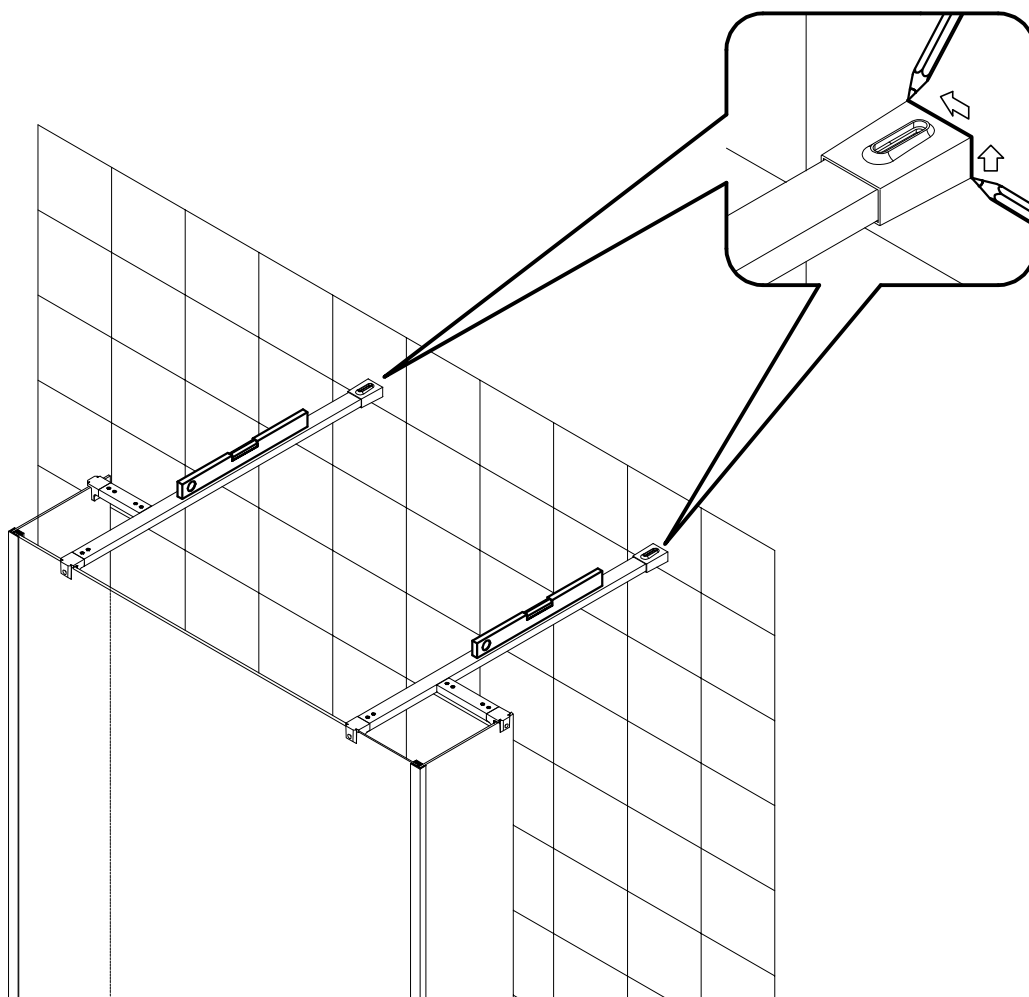

74

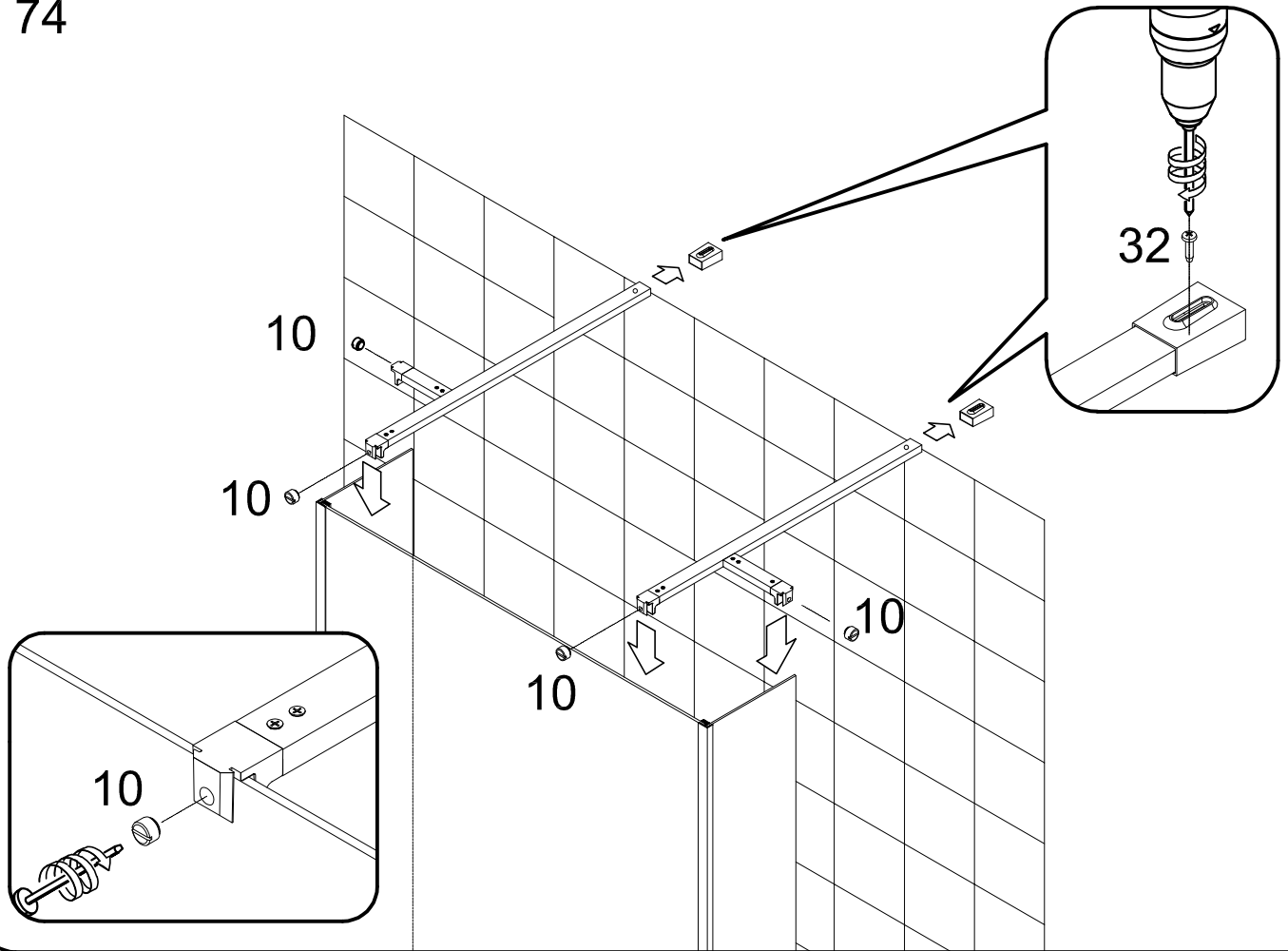

75

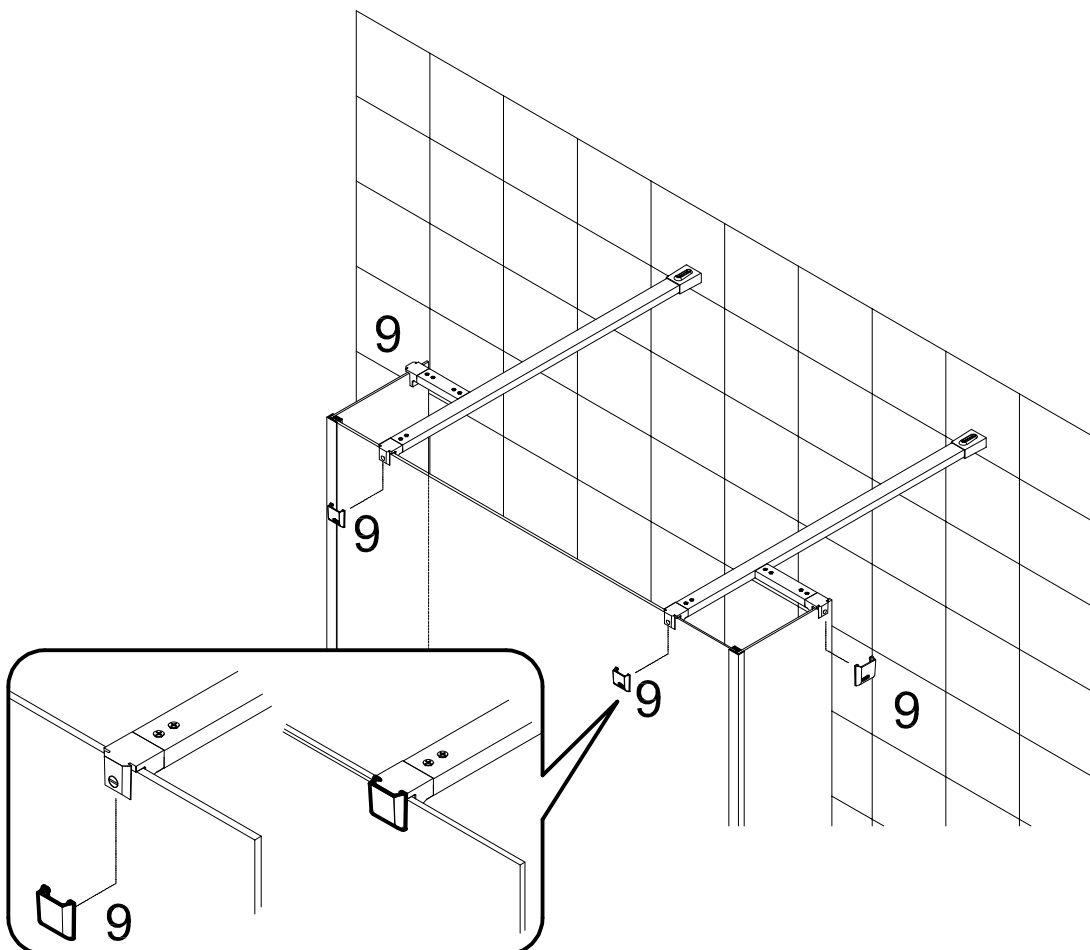



Pag. 1

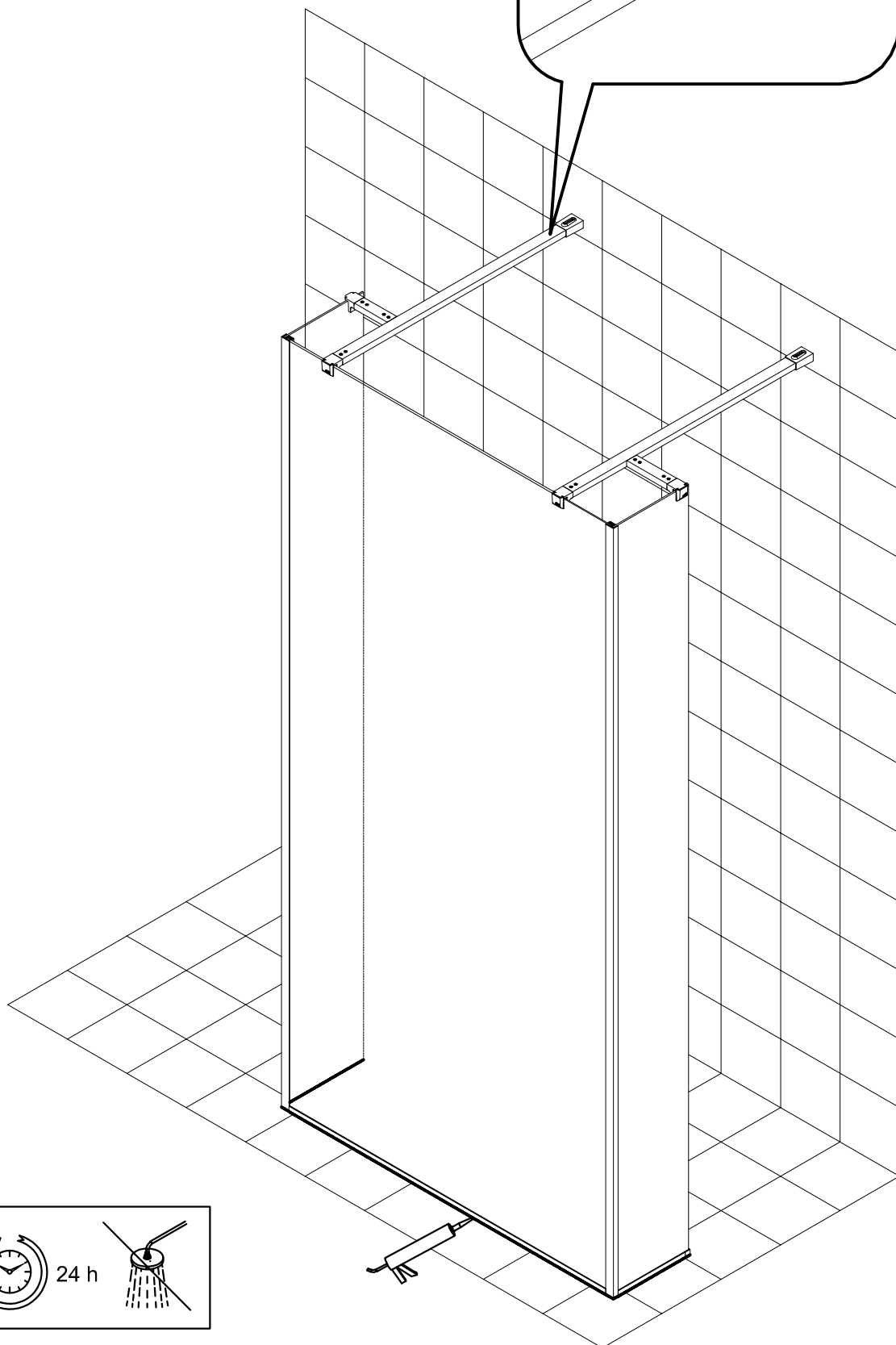
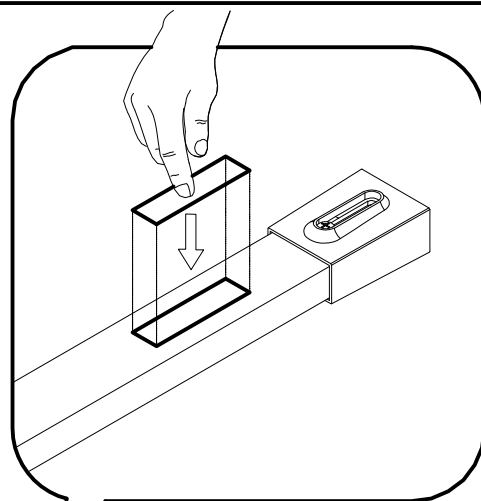
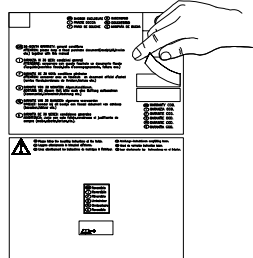

24 h



B0076B**

B0065B**

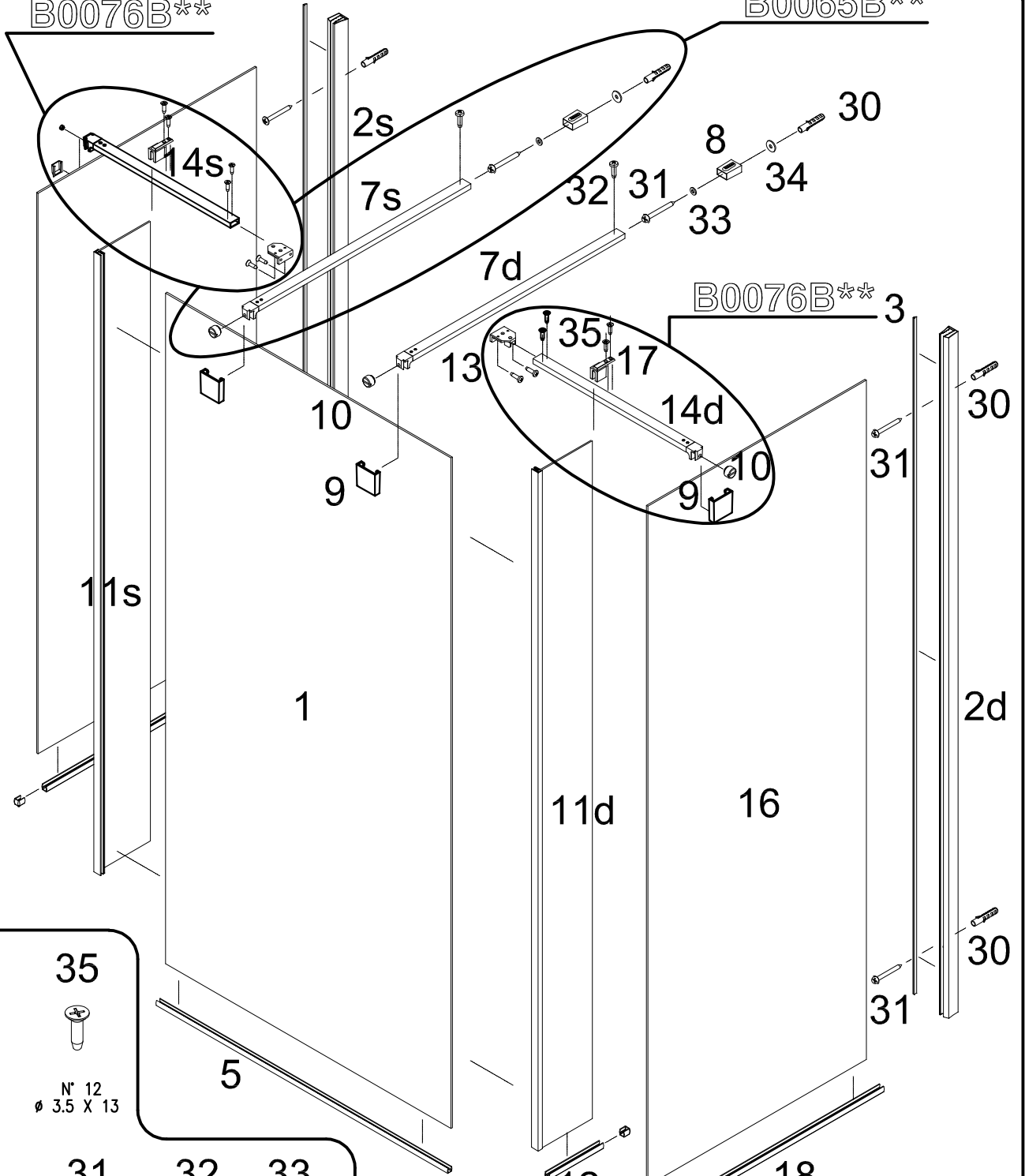

34 N° 2	35 N° 12 Ø 3.5 X 13		
30 N° 2 Ø 6 X 30	31 N° 2 Ø 4,2 X 32	32 N° 2 Ø 3.5 X 13	33 N° 2

Safety icons: a warning triangle with an exclamation mark, a triangle with a lightning bolt, and a triangle with the word "GAS".

Tools and materials: a drill bit (Ø3, Ø6), a hand saw, a power drill, a level, and a pencil.

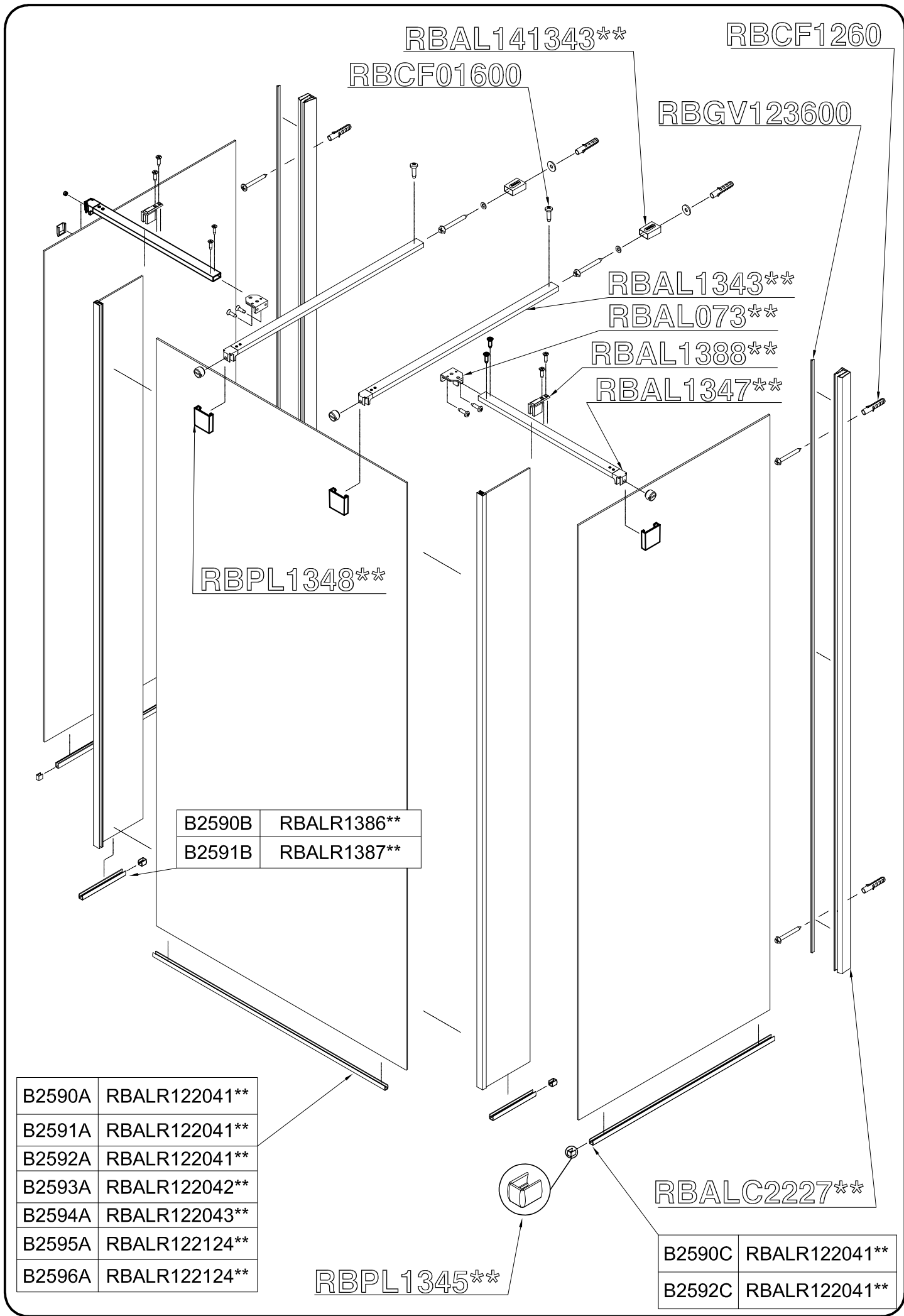

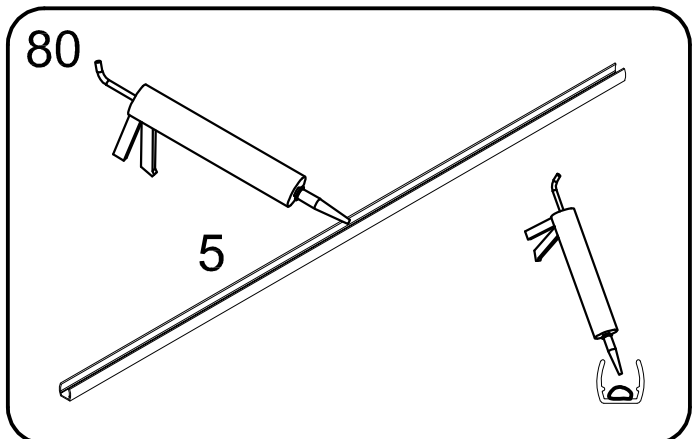
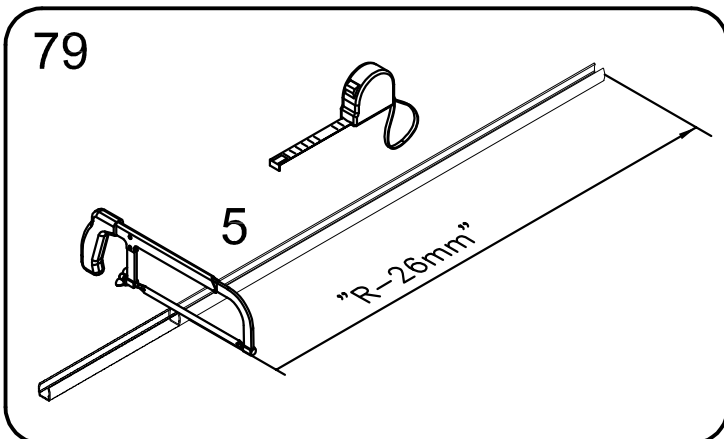
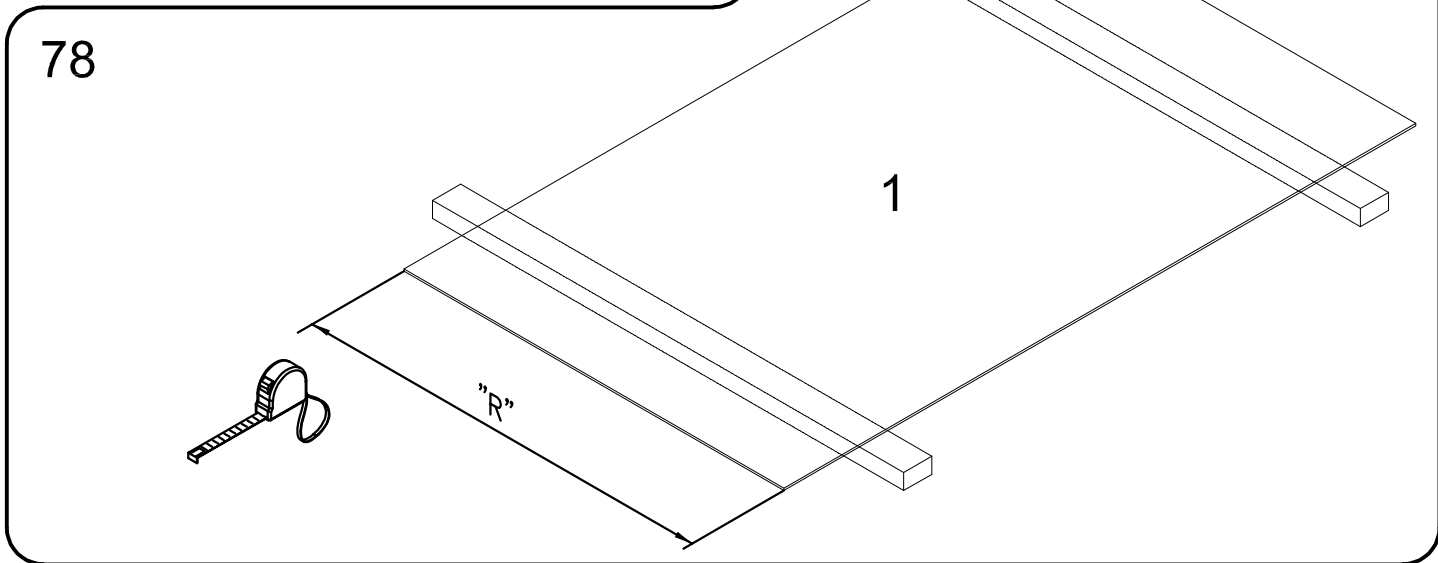
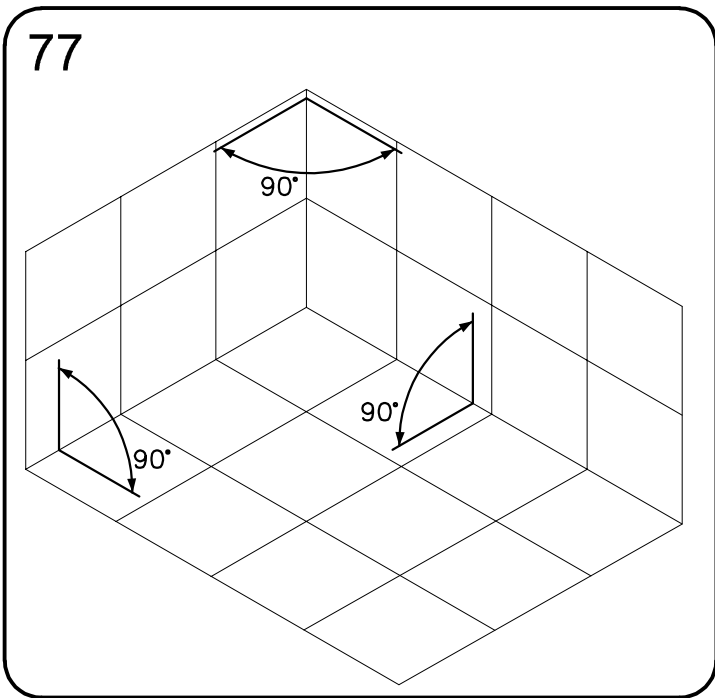
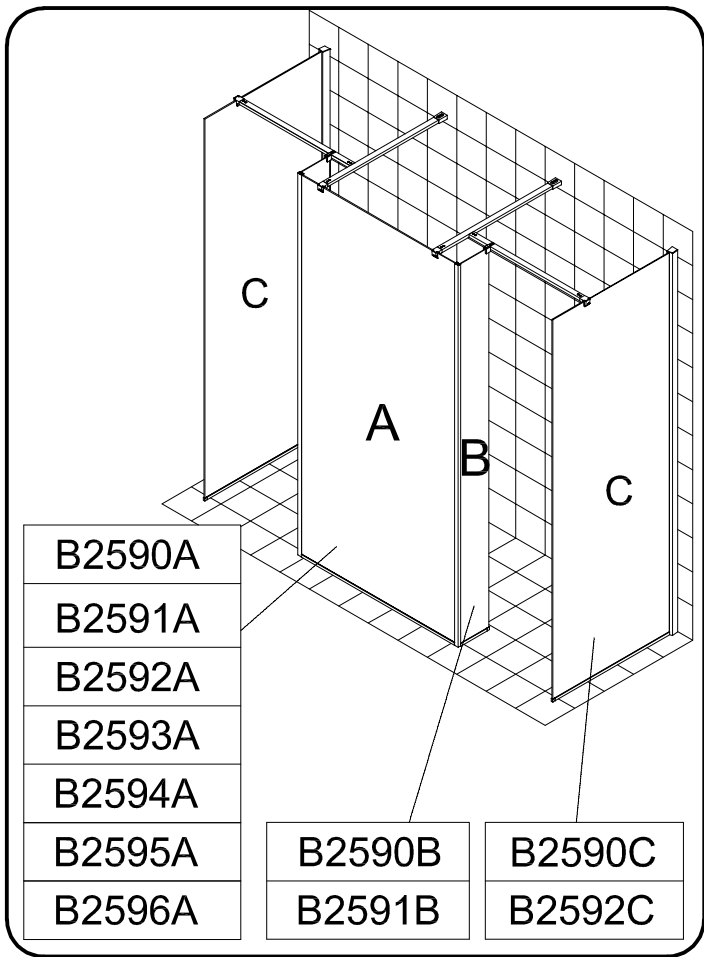

81

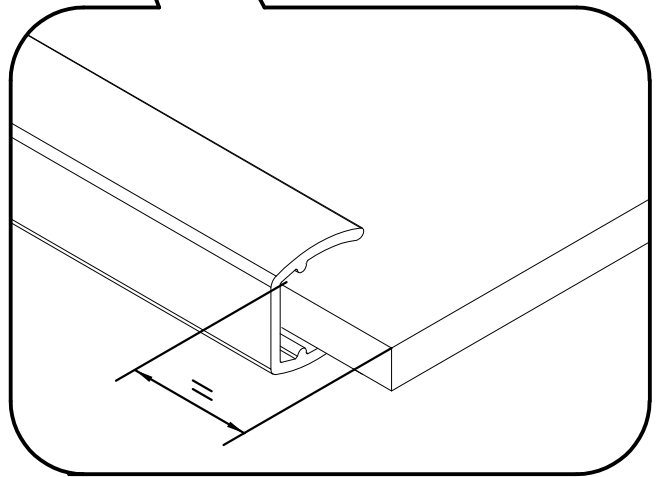
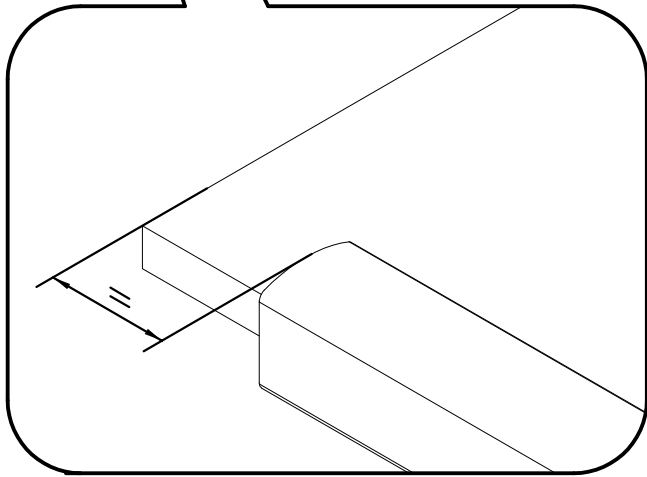
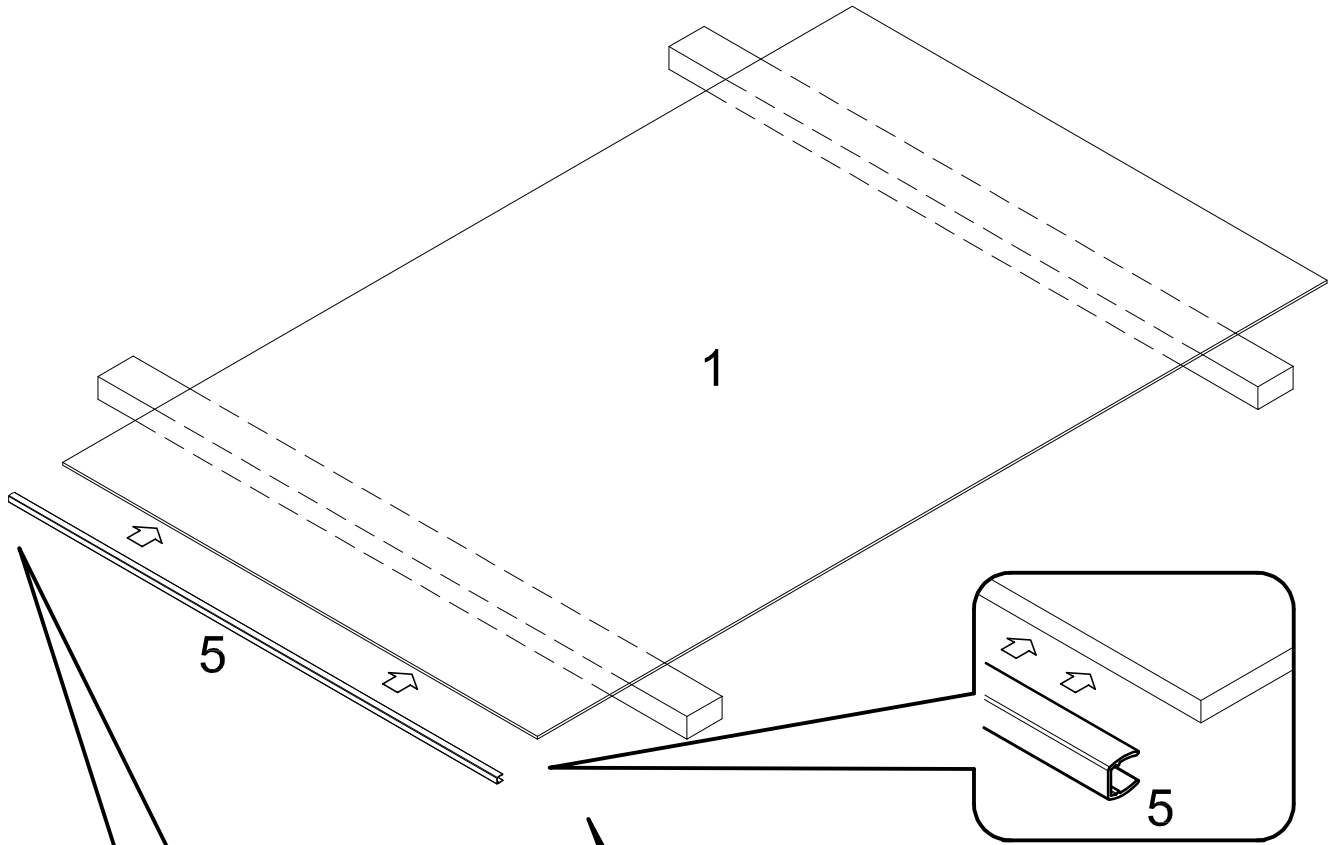

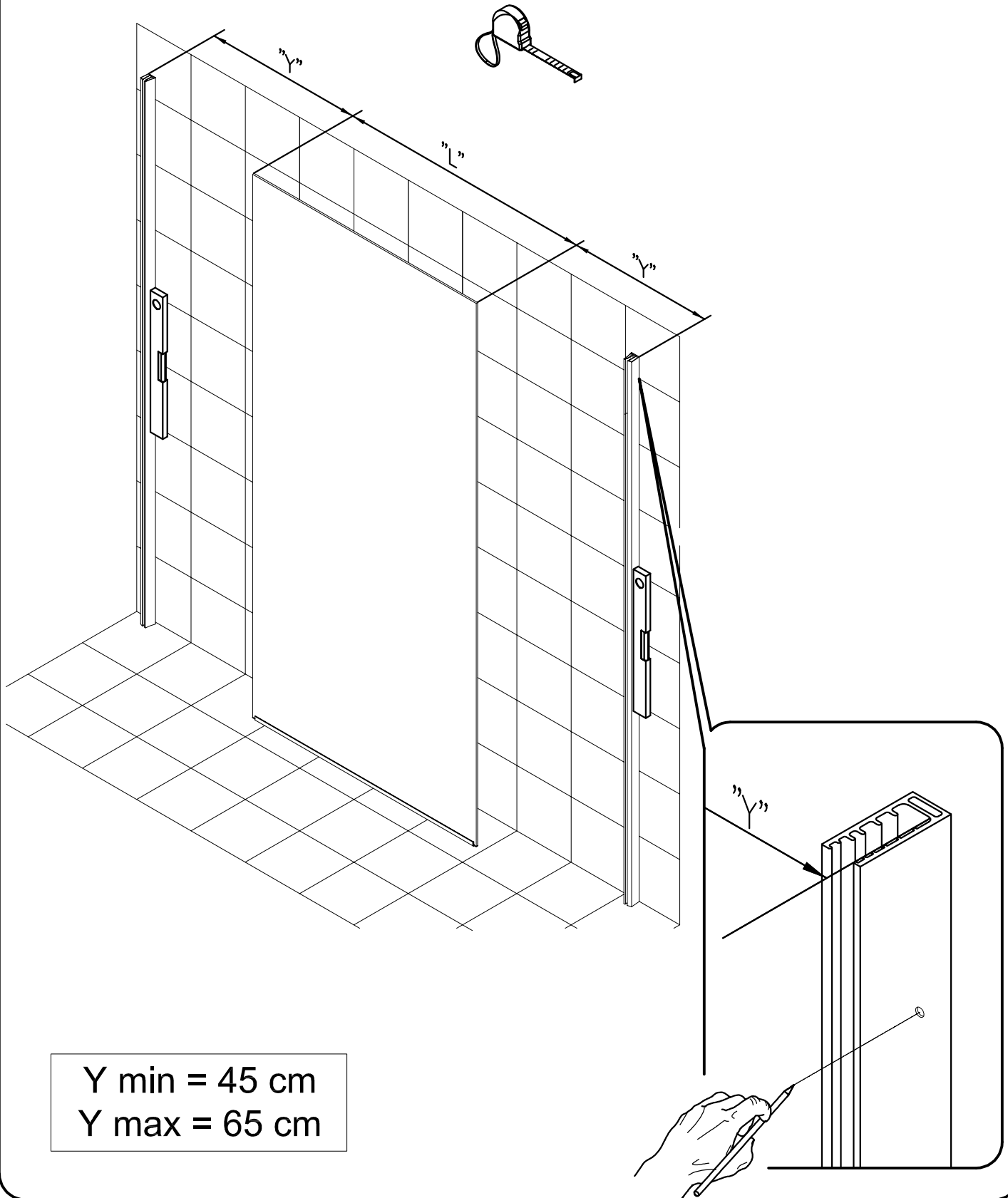

Y min = 45 cm
Y max = 65 cm

83

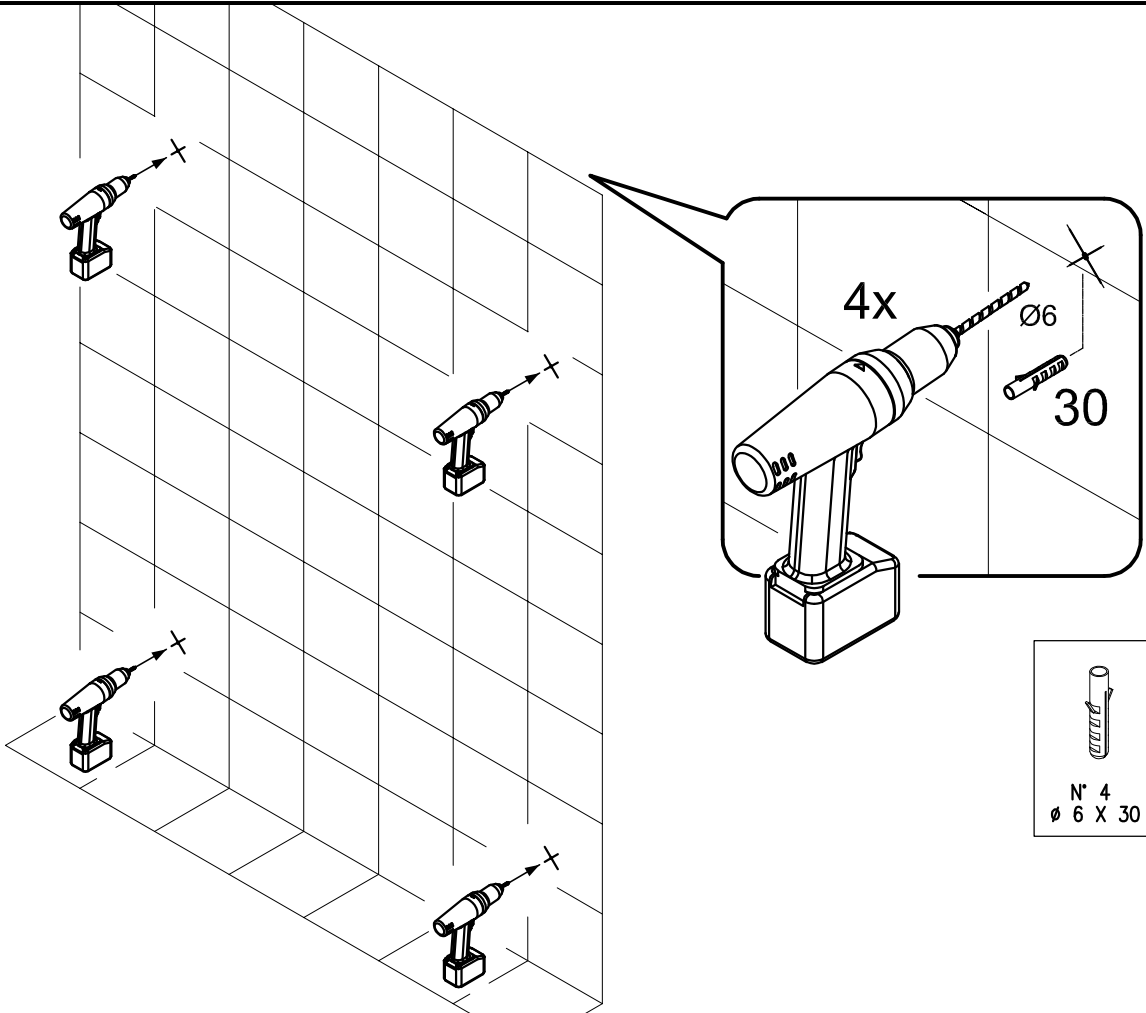

84

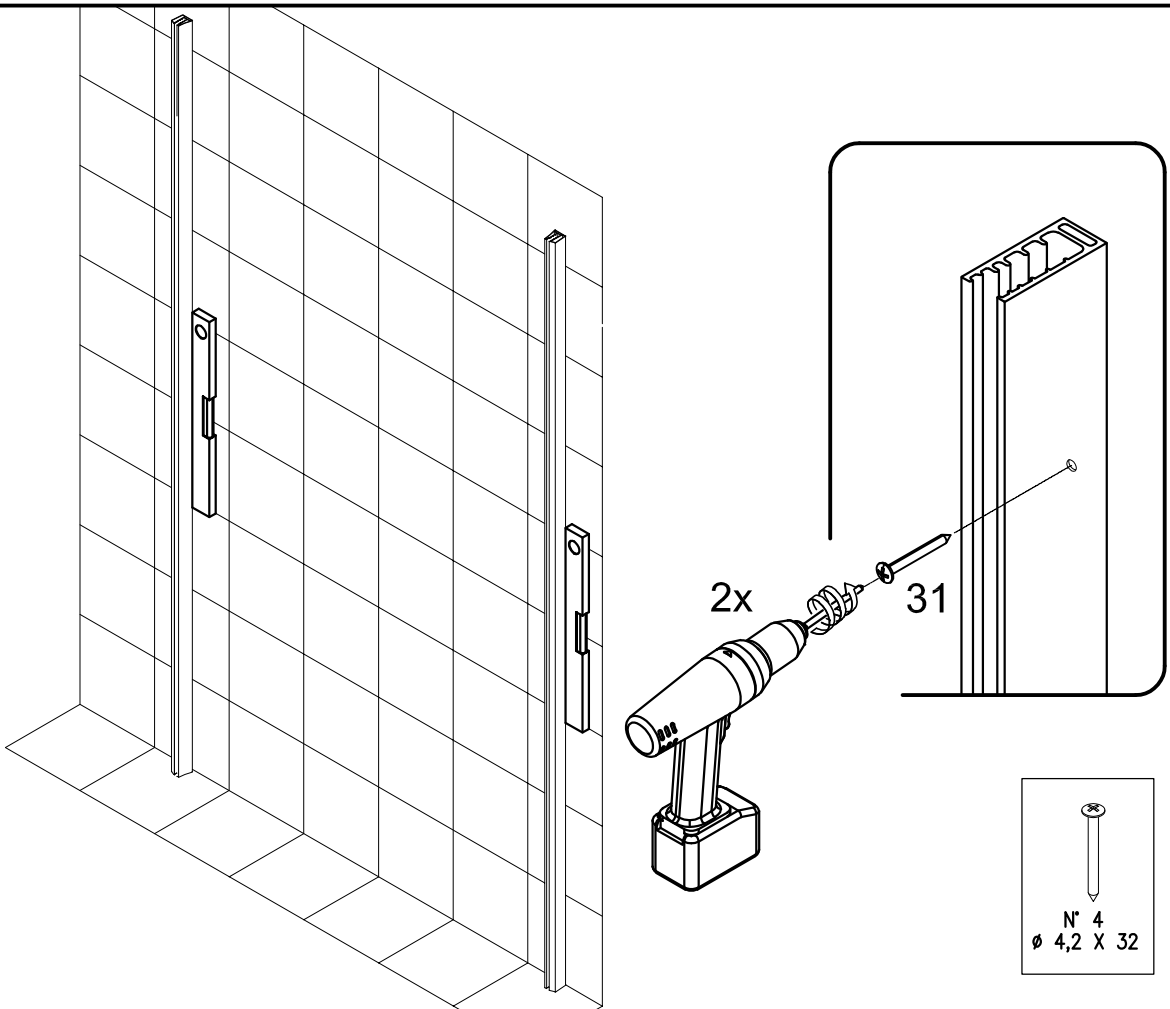

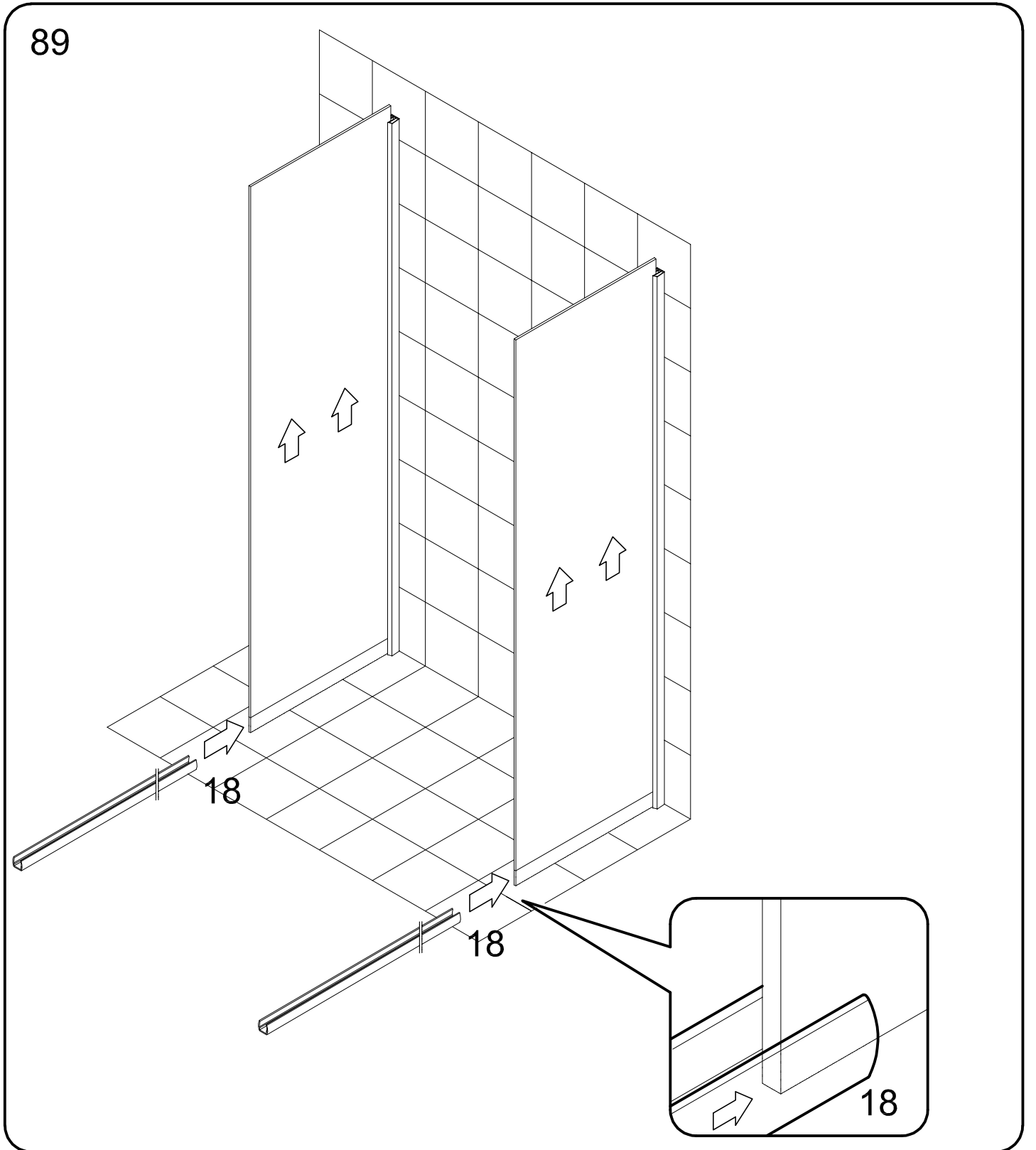
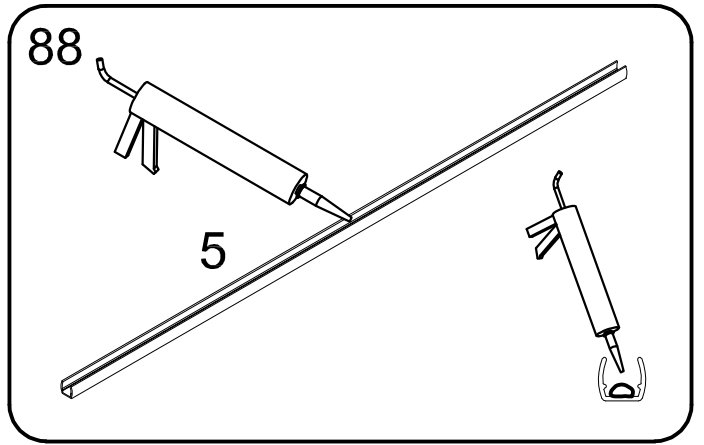
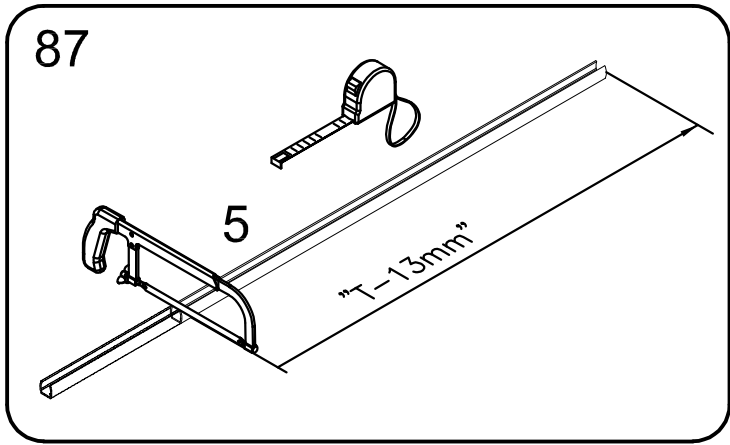

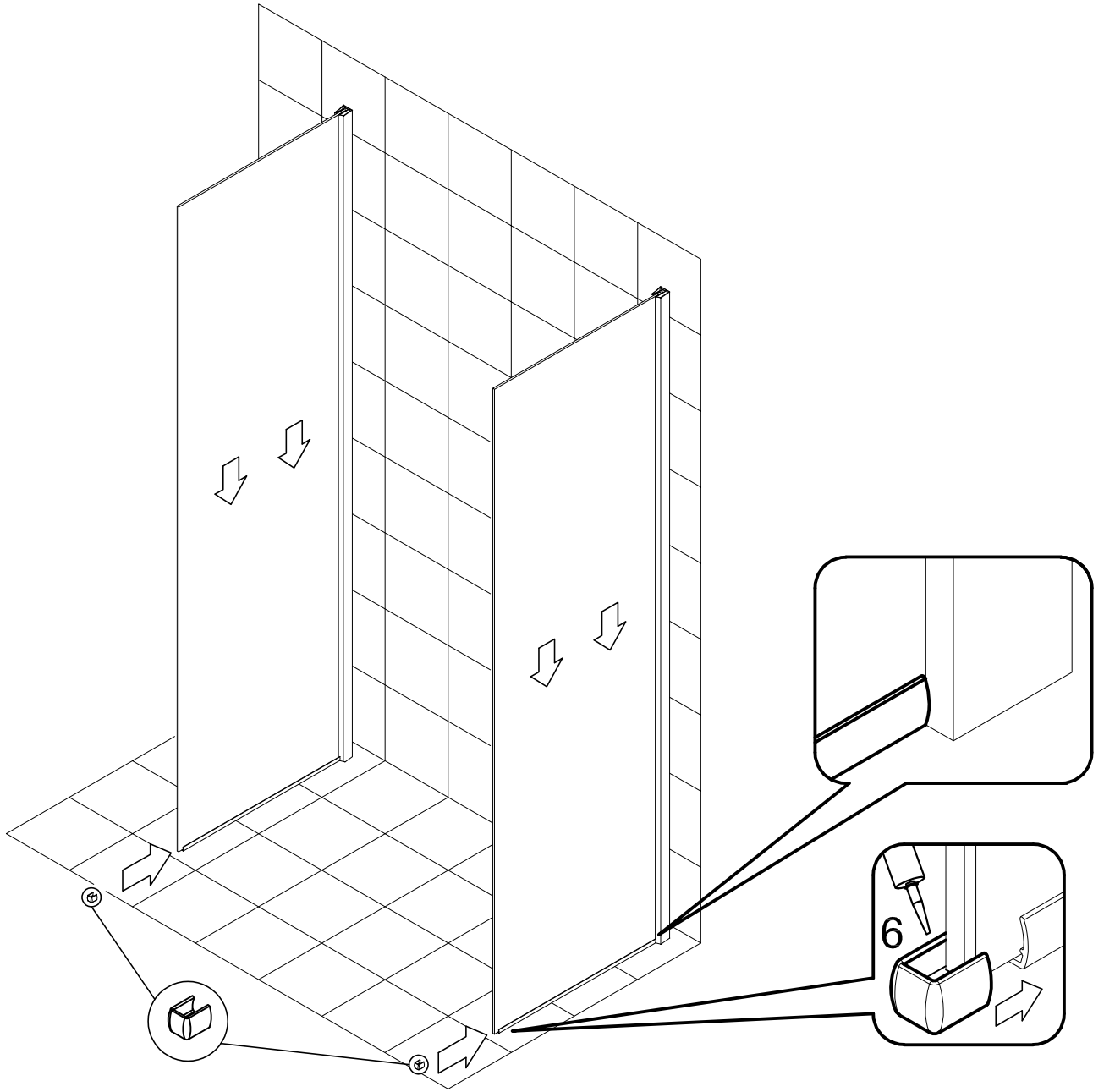

91

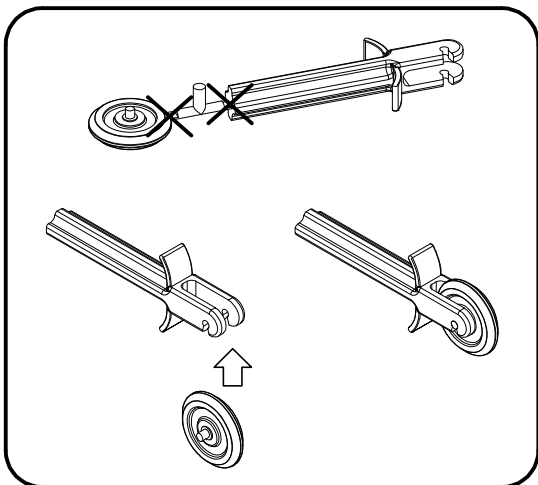
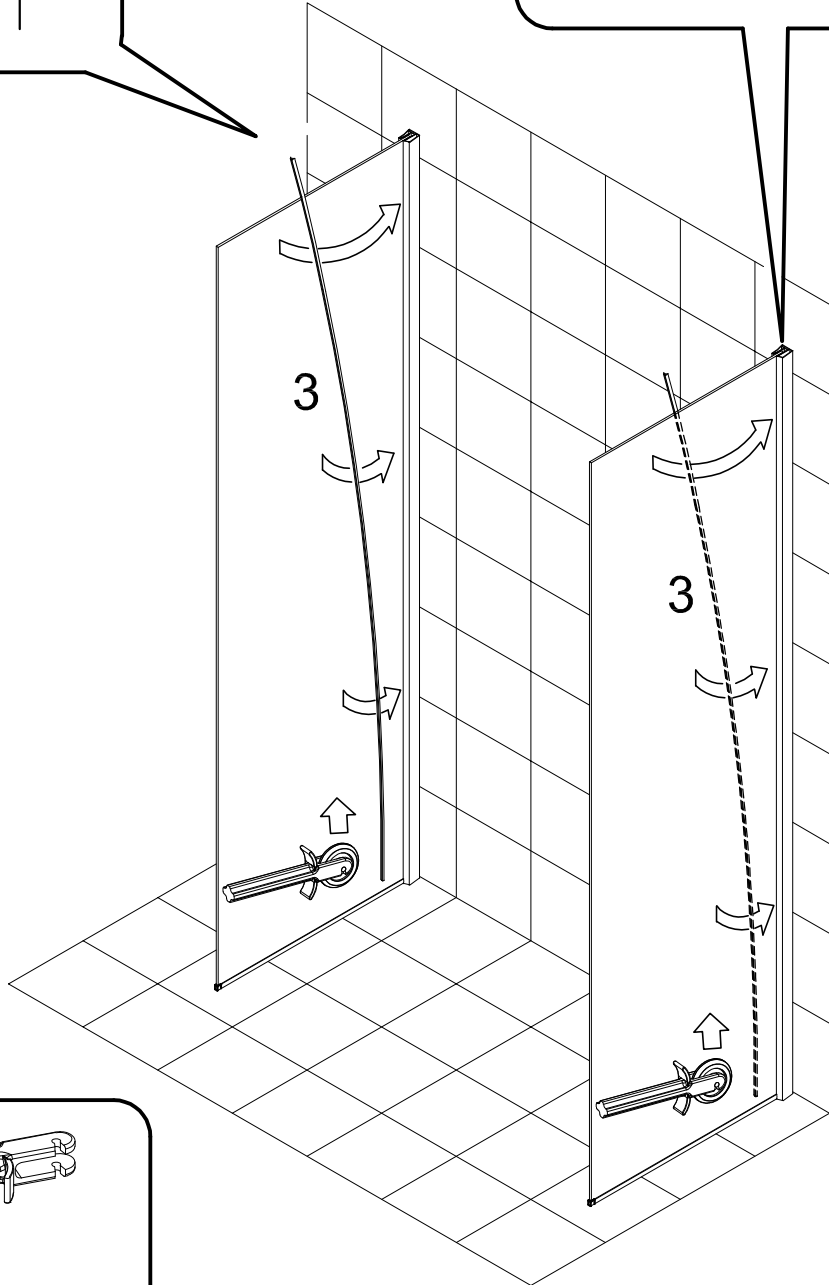
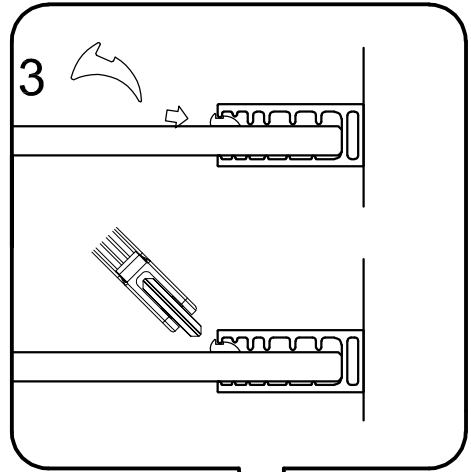
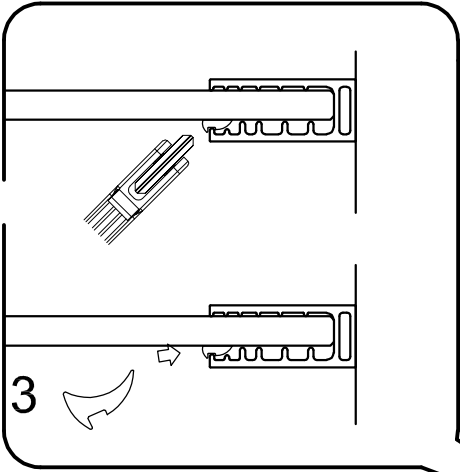

92

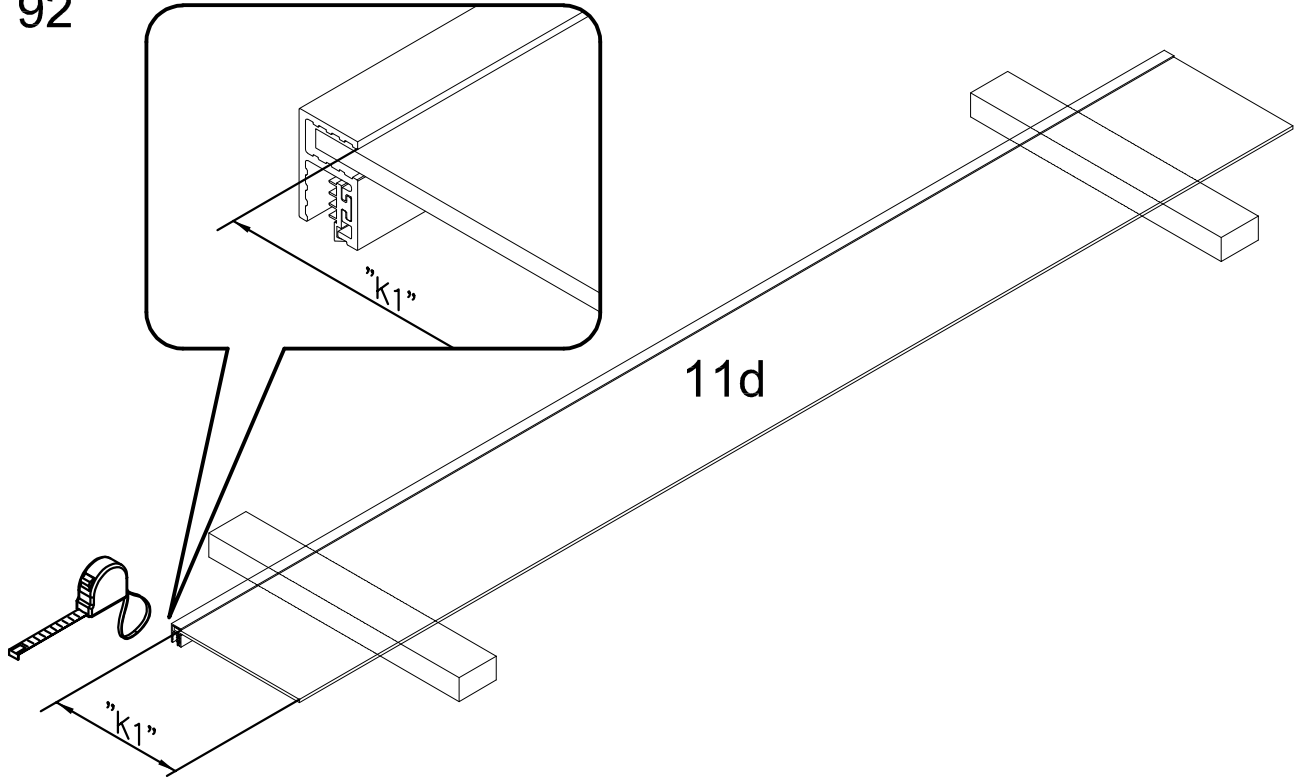

93

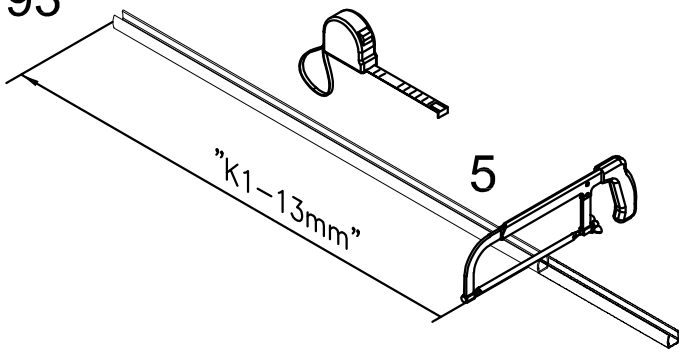

94

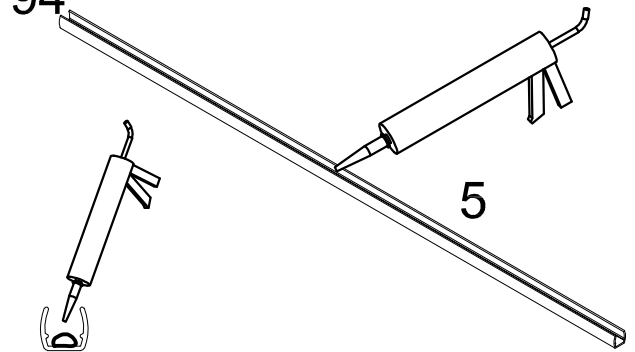

95

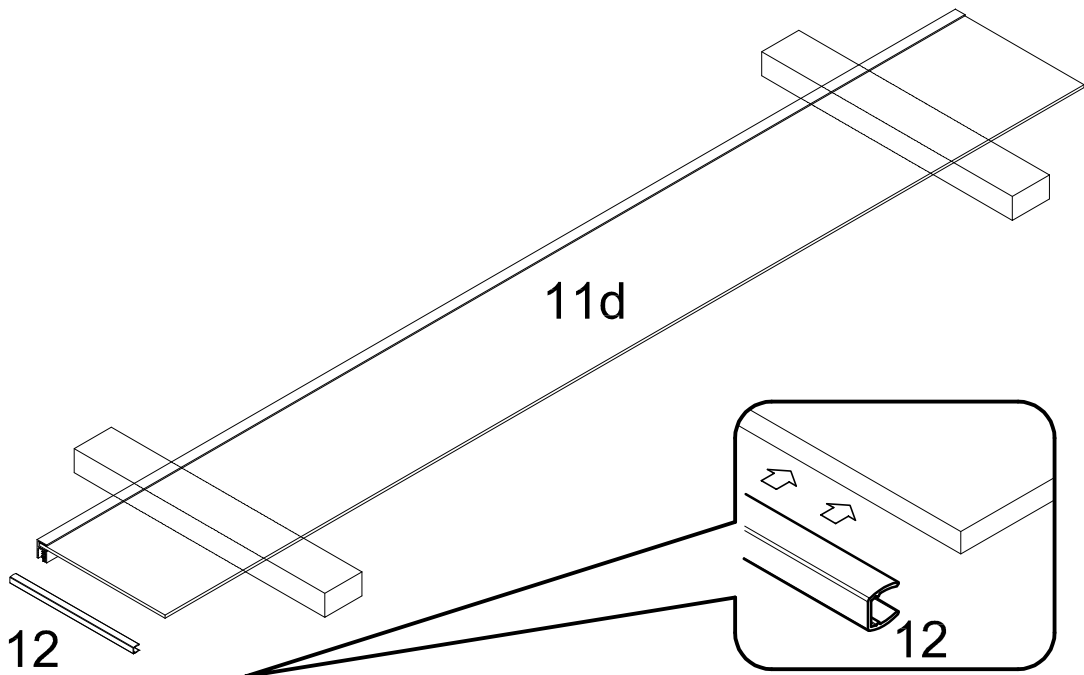

96

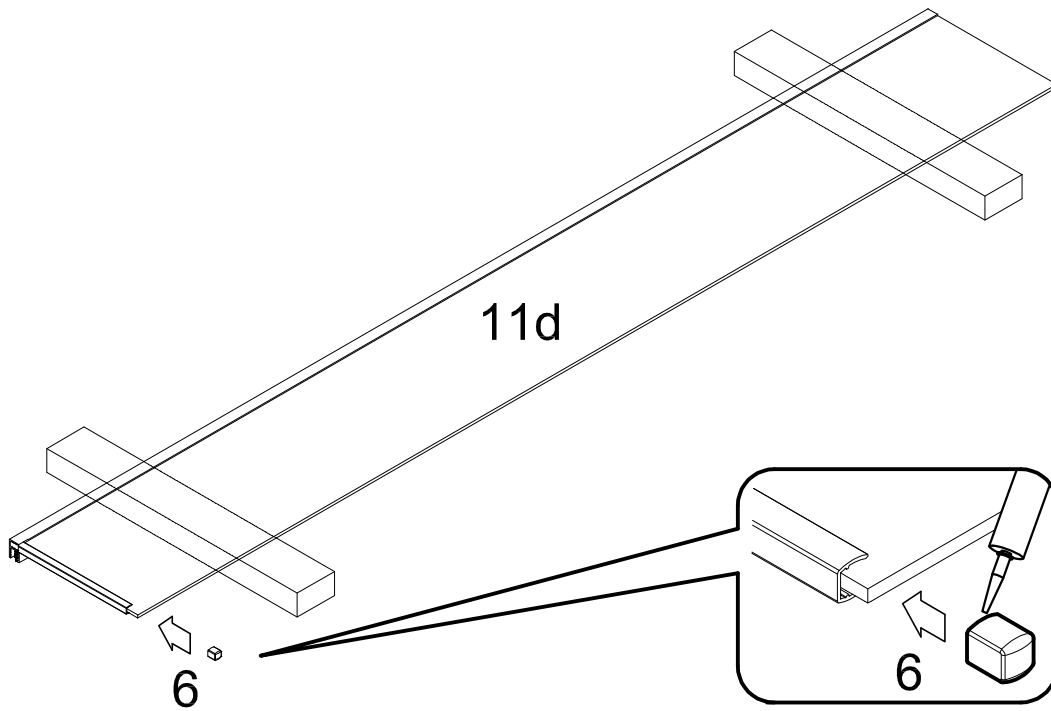

97

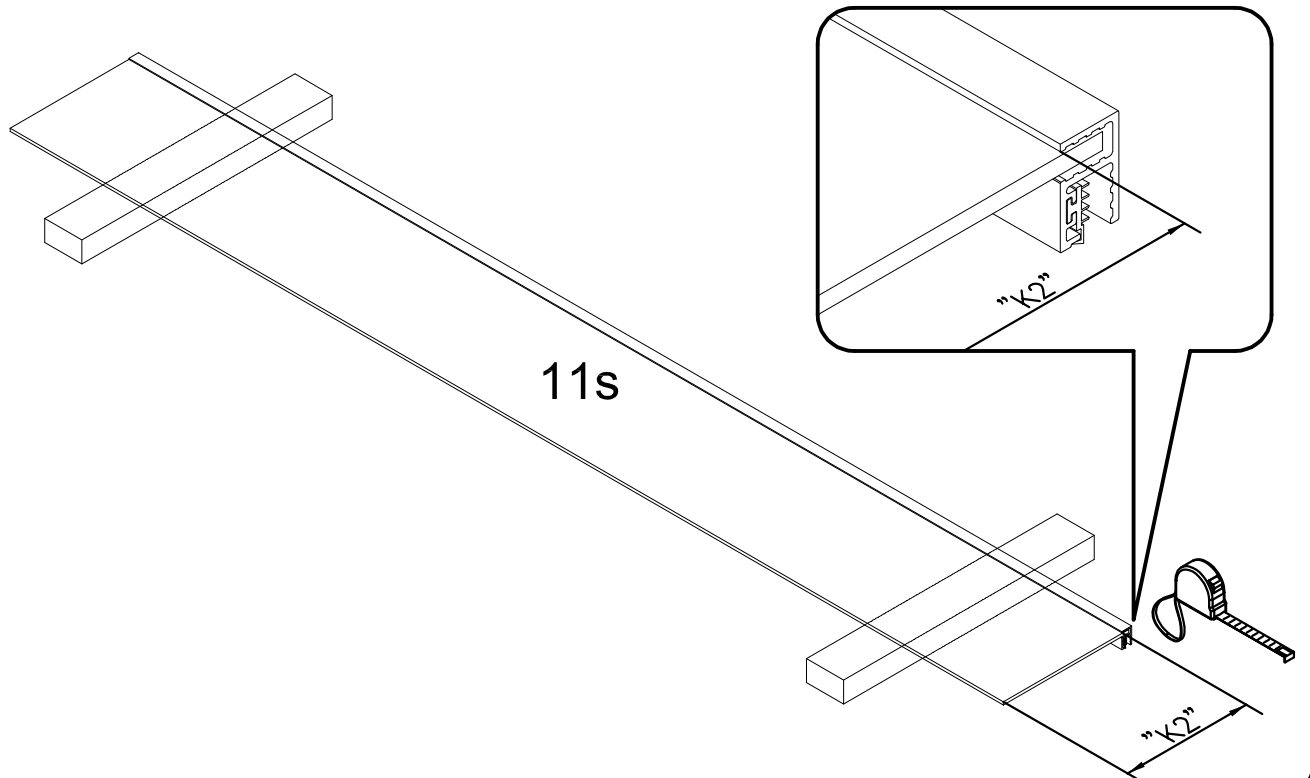

98

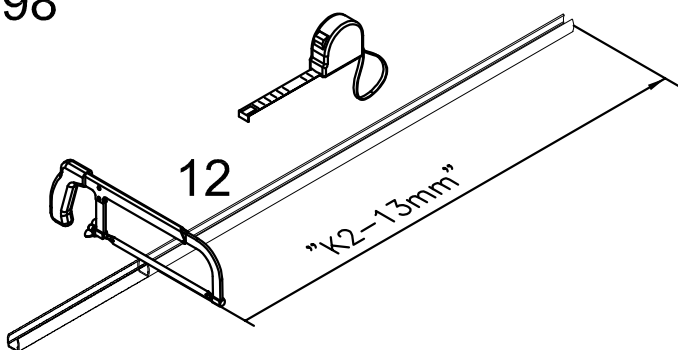

99

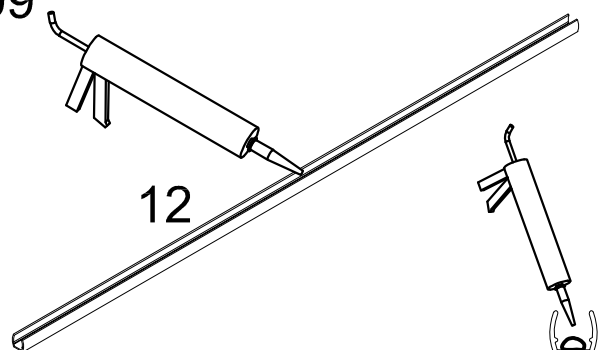

100

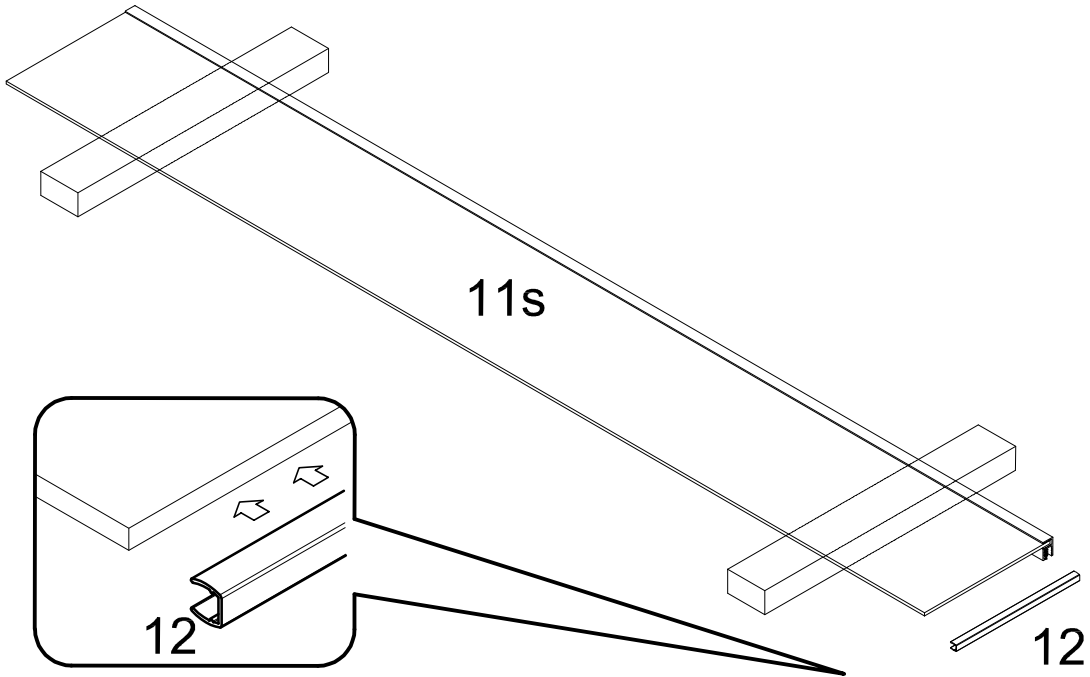

101

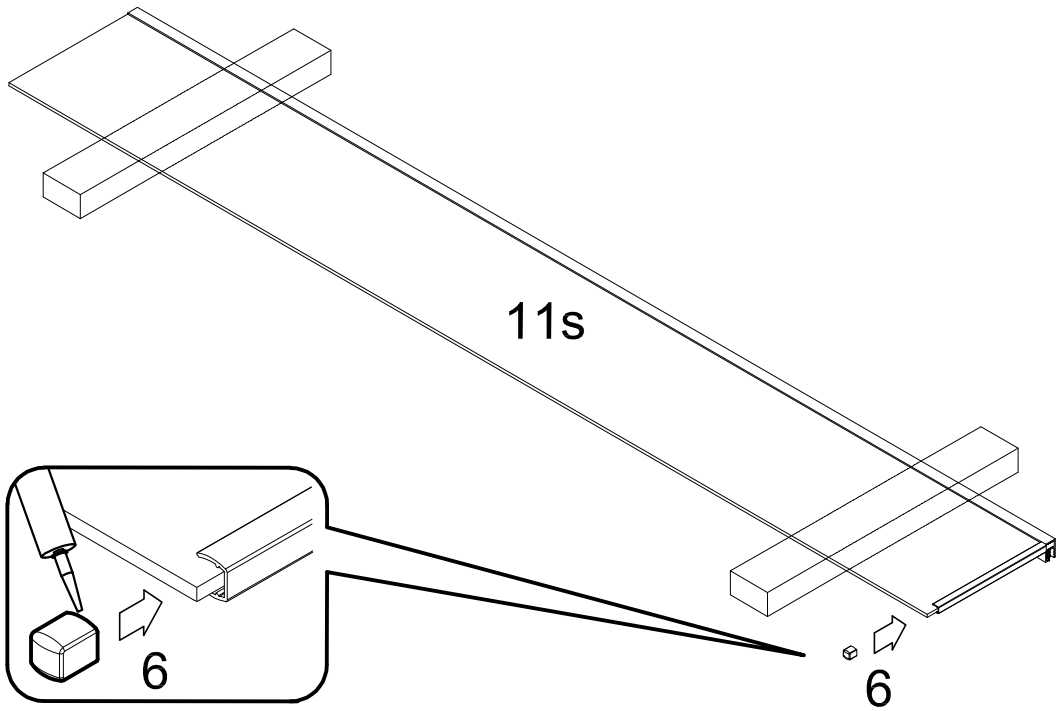

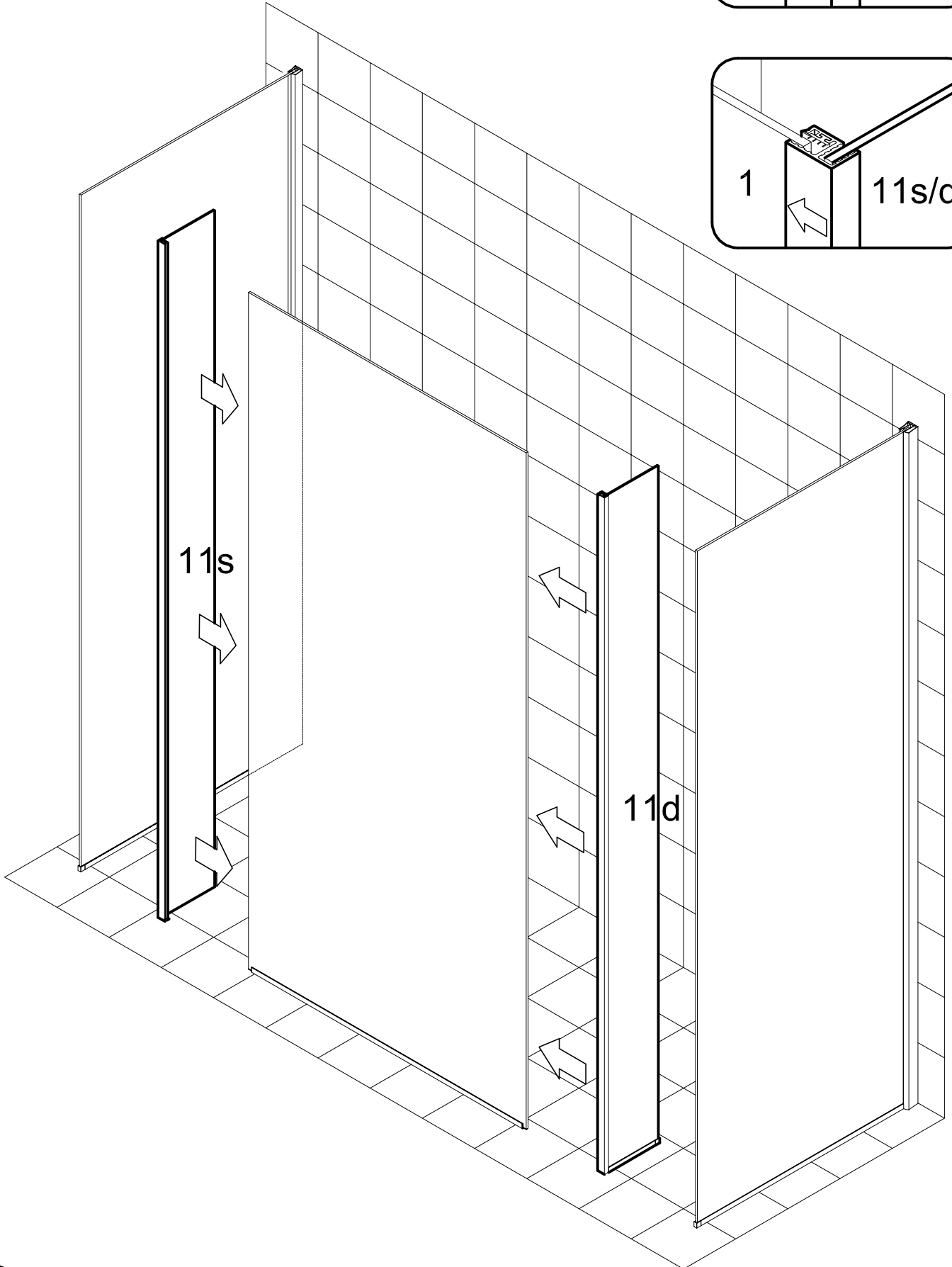
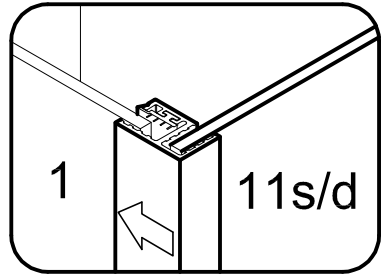
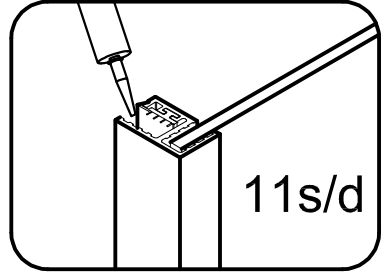

103

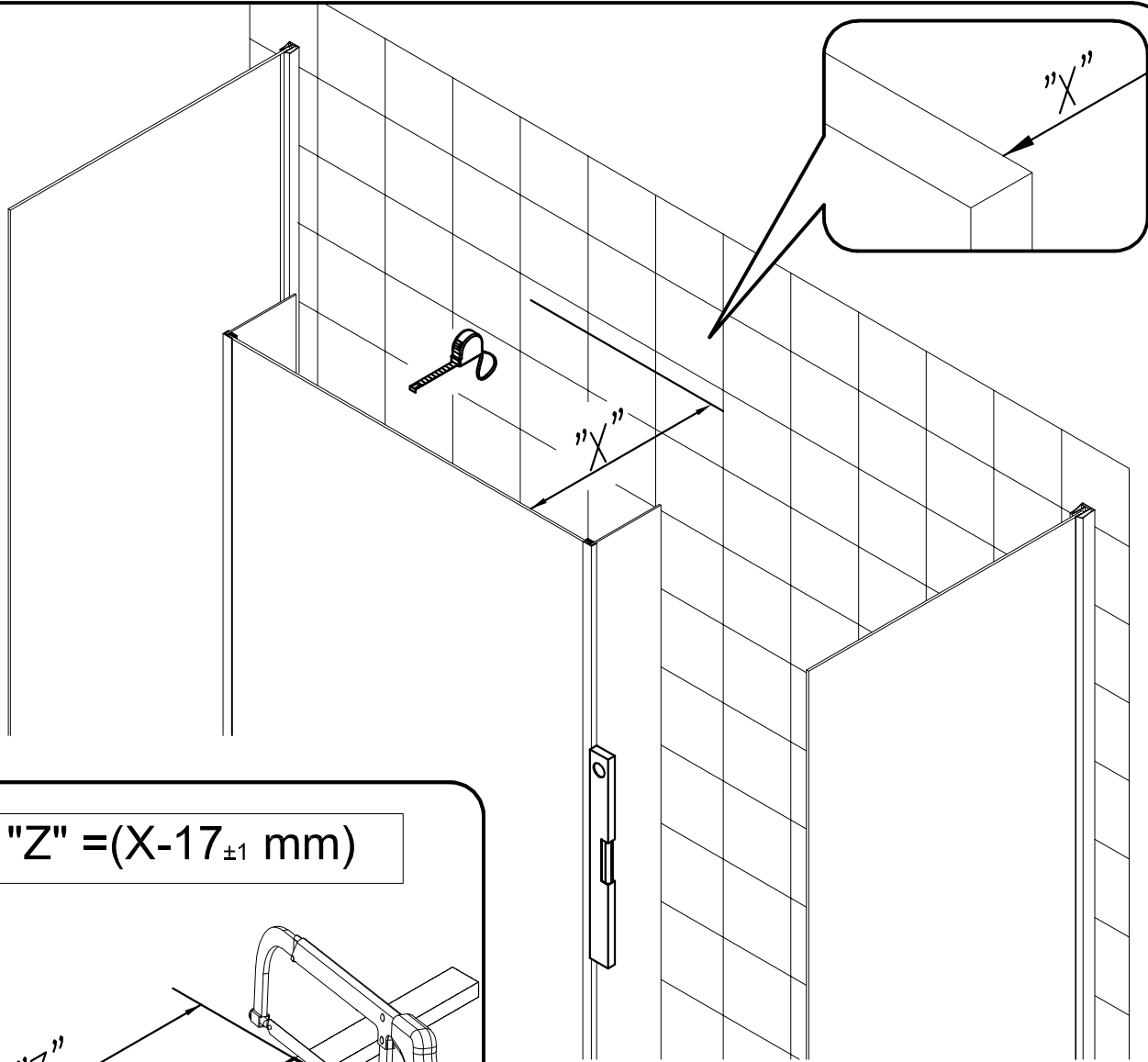

$$"Z" = (X - 17_{\pm 1} \text{ mm})$$

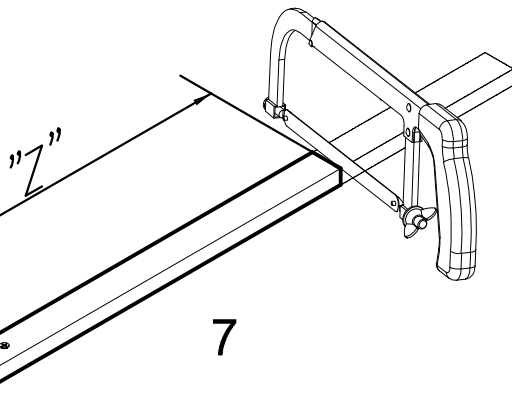

"X" max = 1200 mm

104

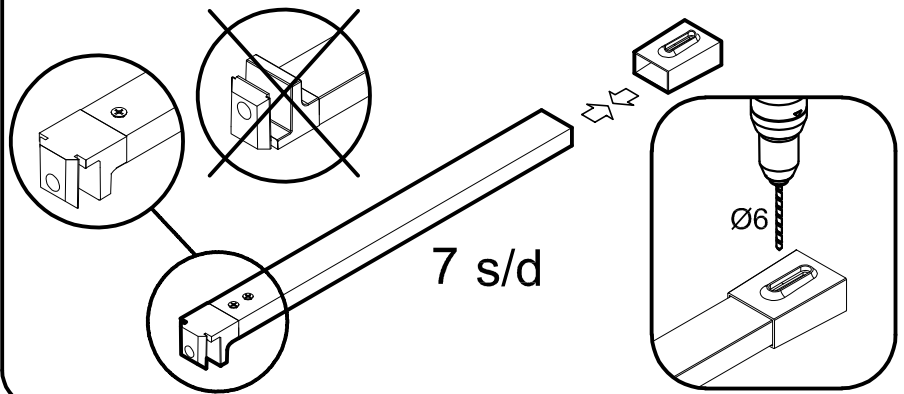
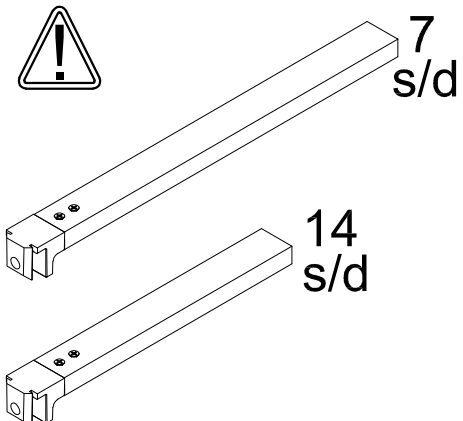

105

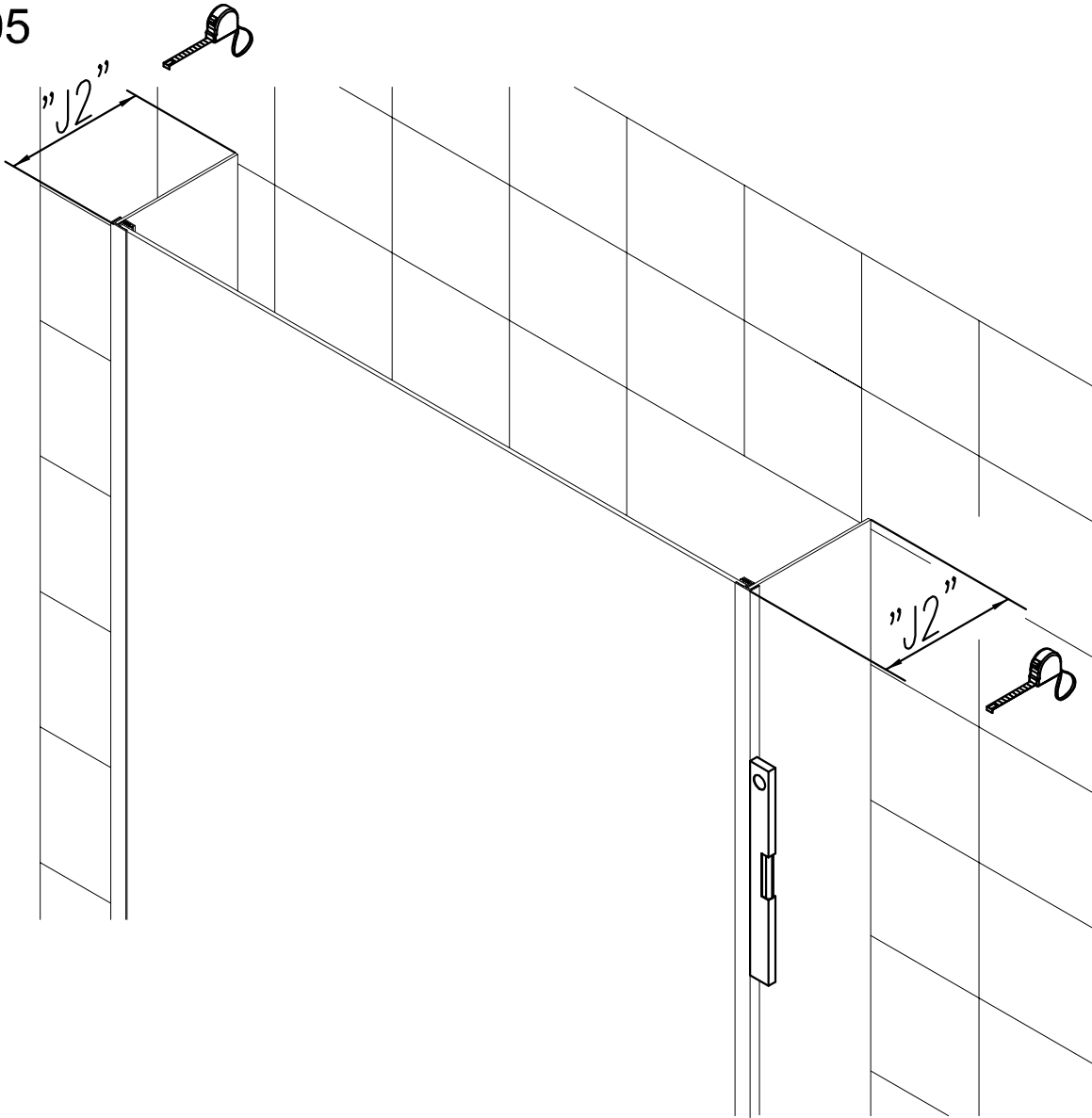

106

$$\text{"K1"} = (J1 + 20 \text{ mm})$$

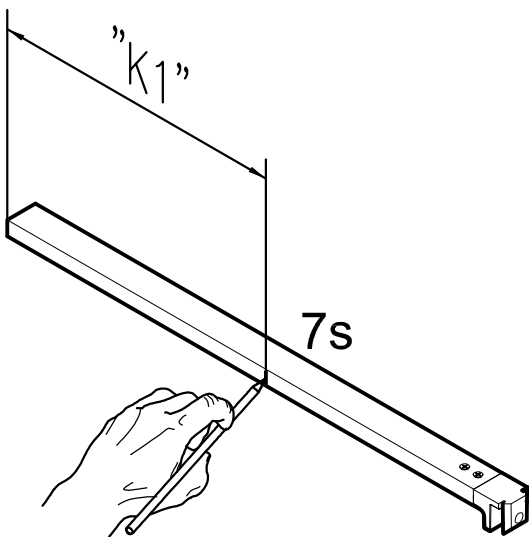

107

$$\text{"K2"} = (J2 + 20 \text{ mm})$$

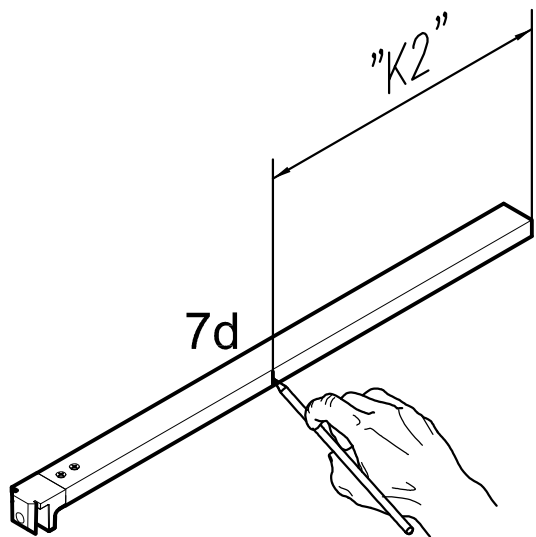

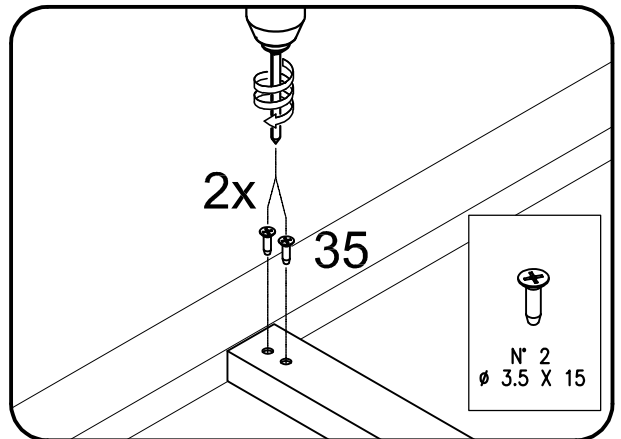
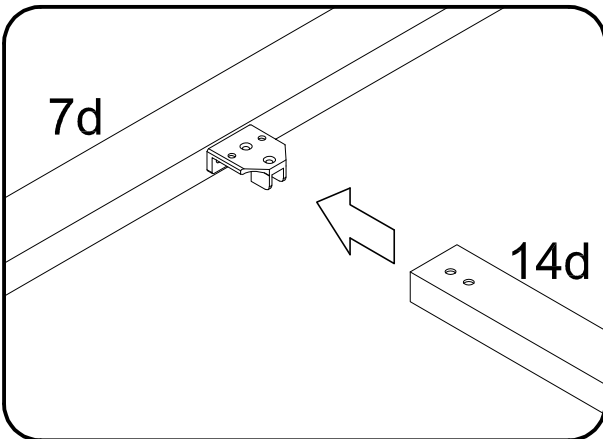
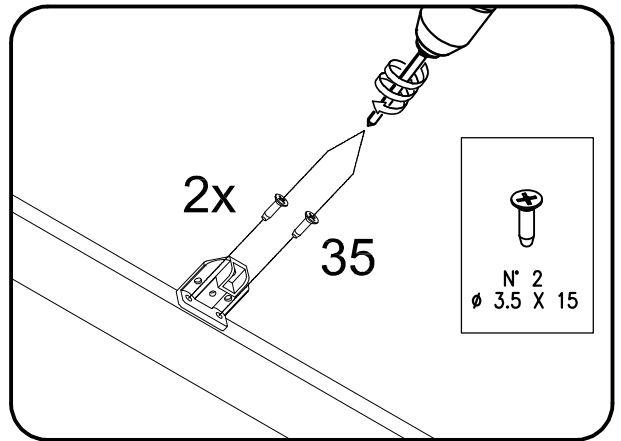
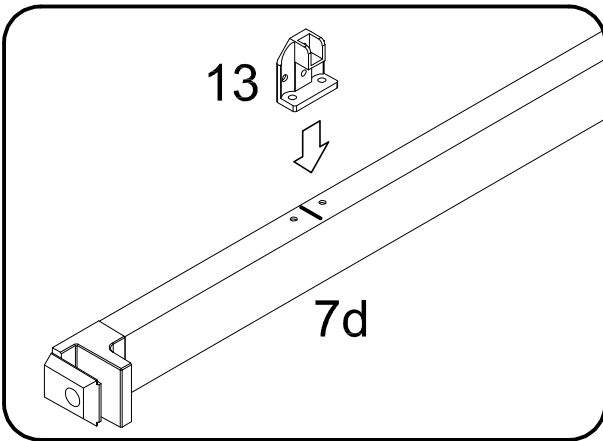
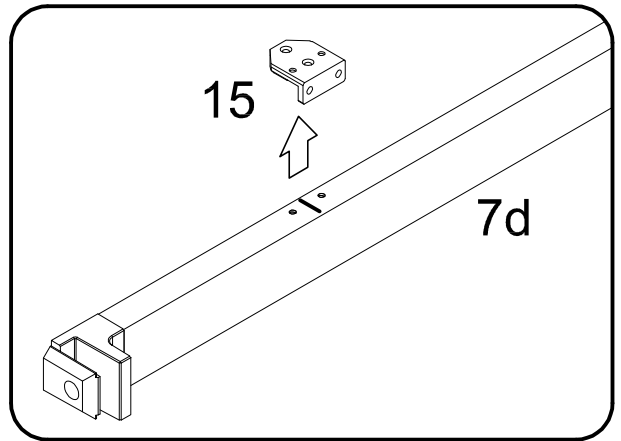
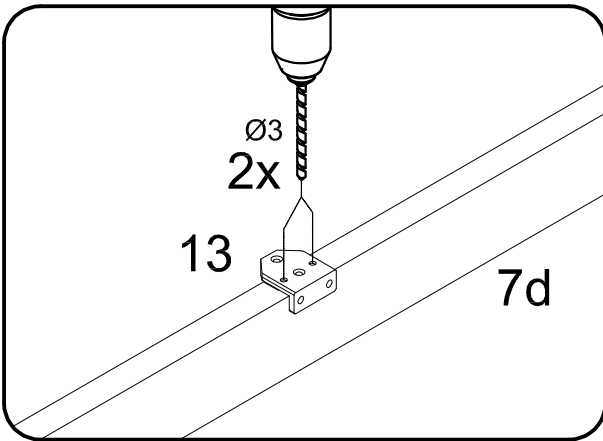
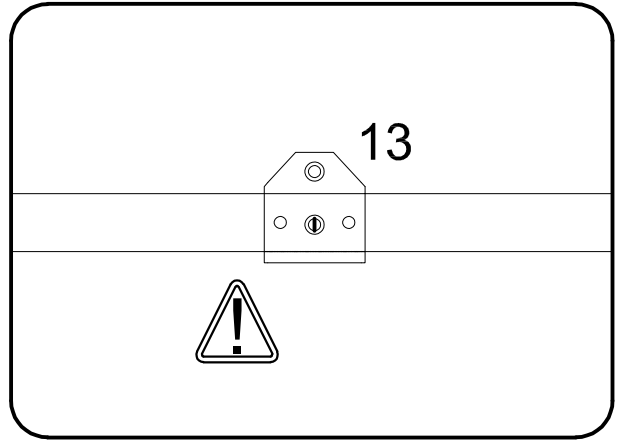
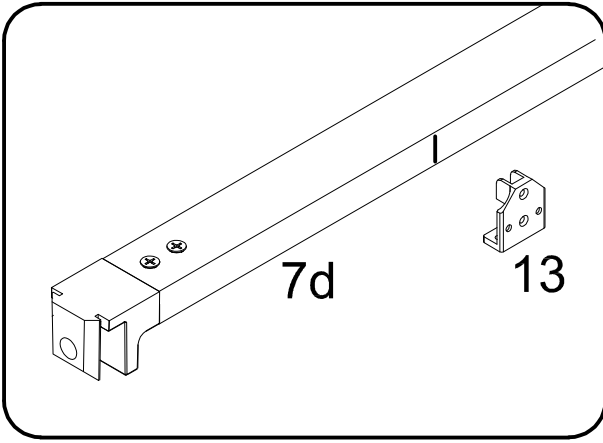

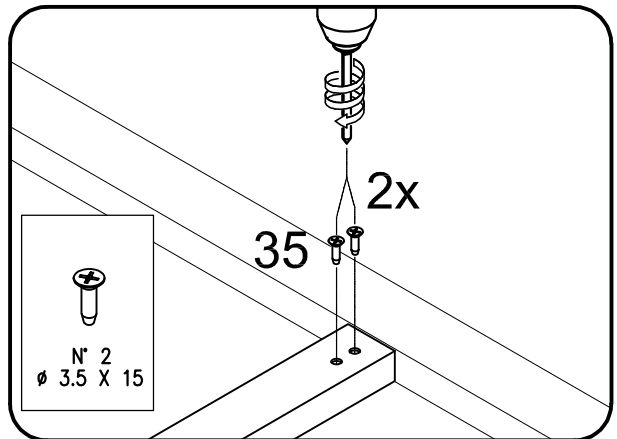
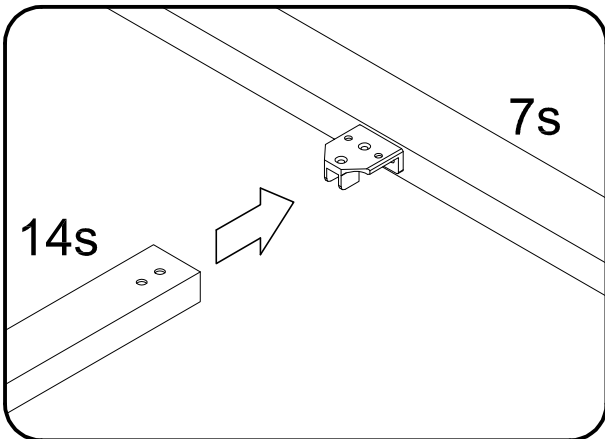
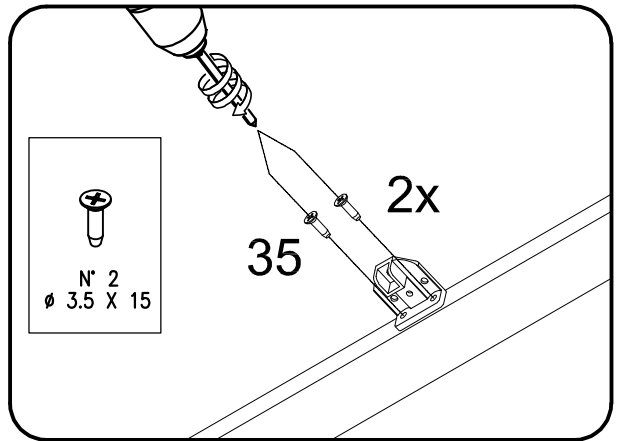
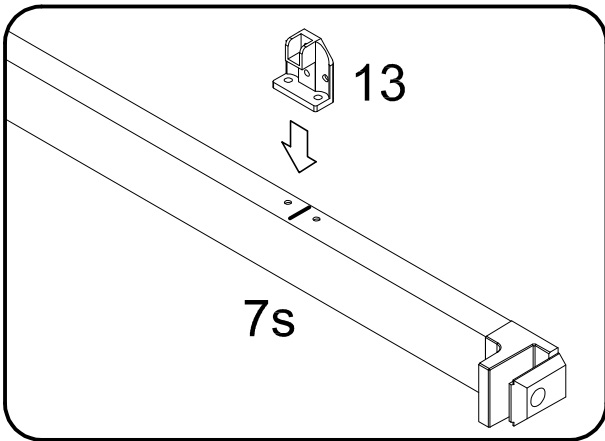
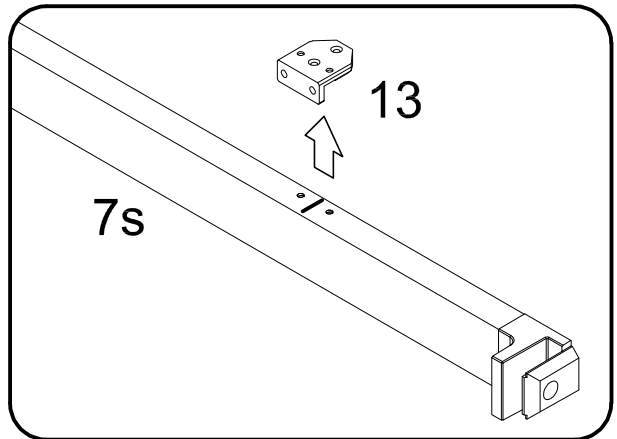
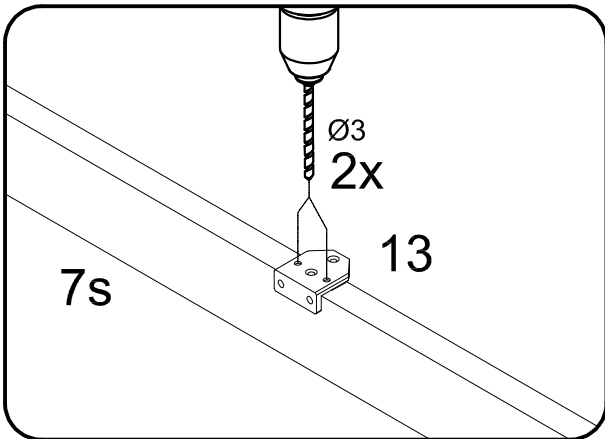
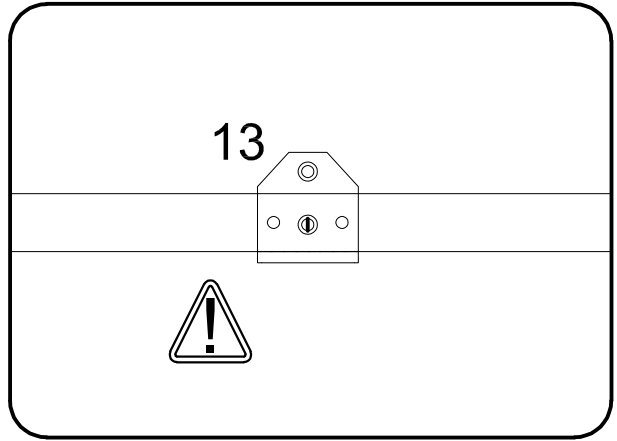
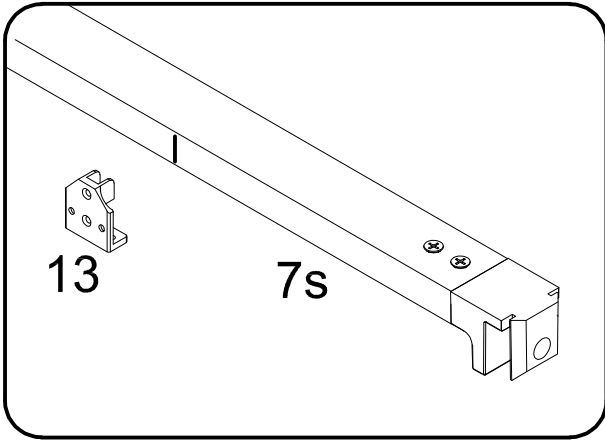

110

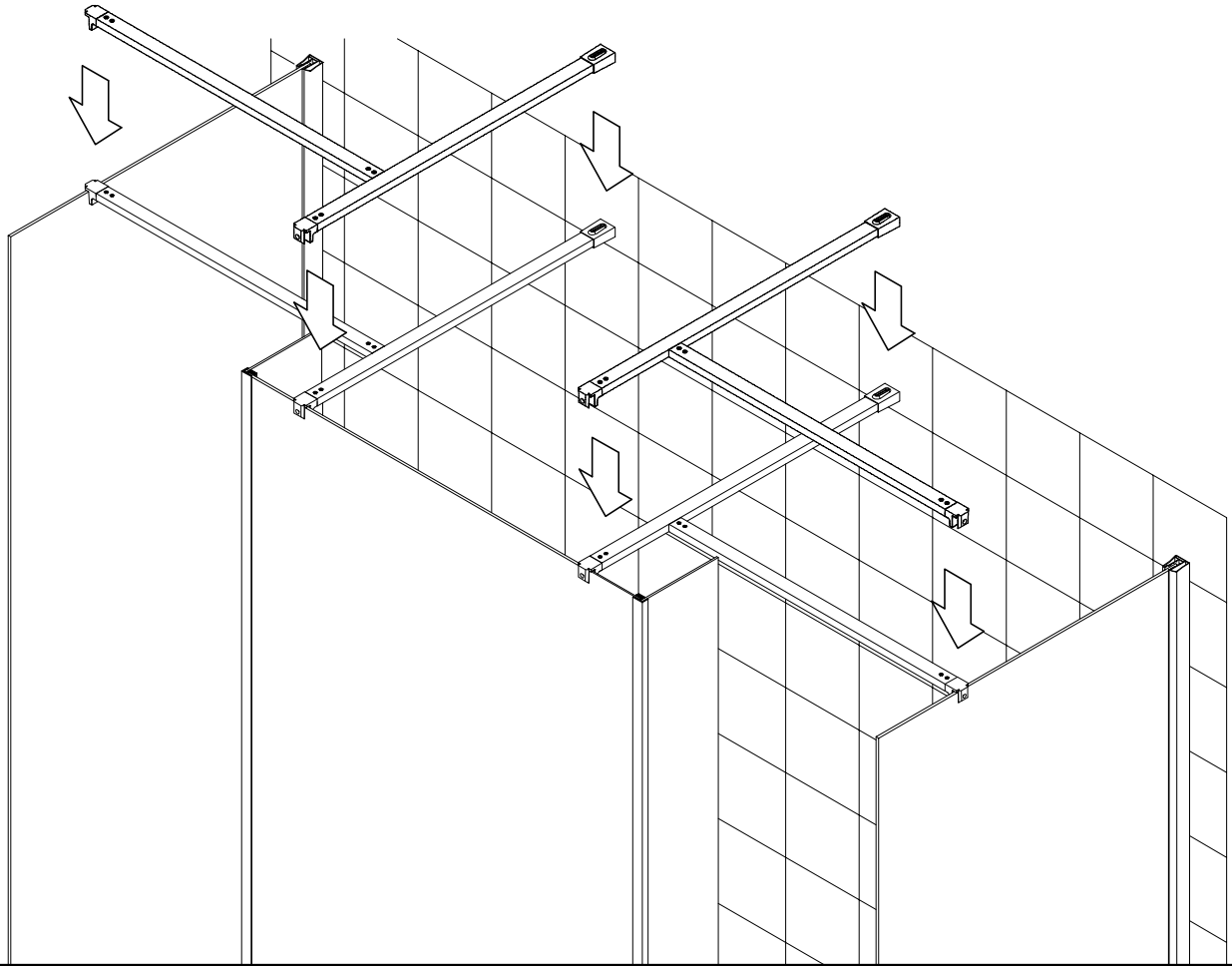

111

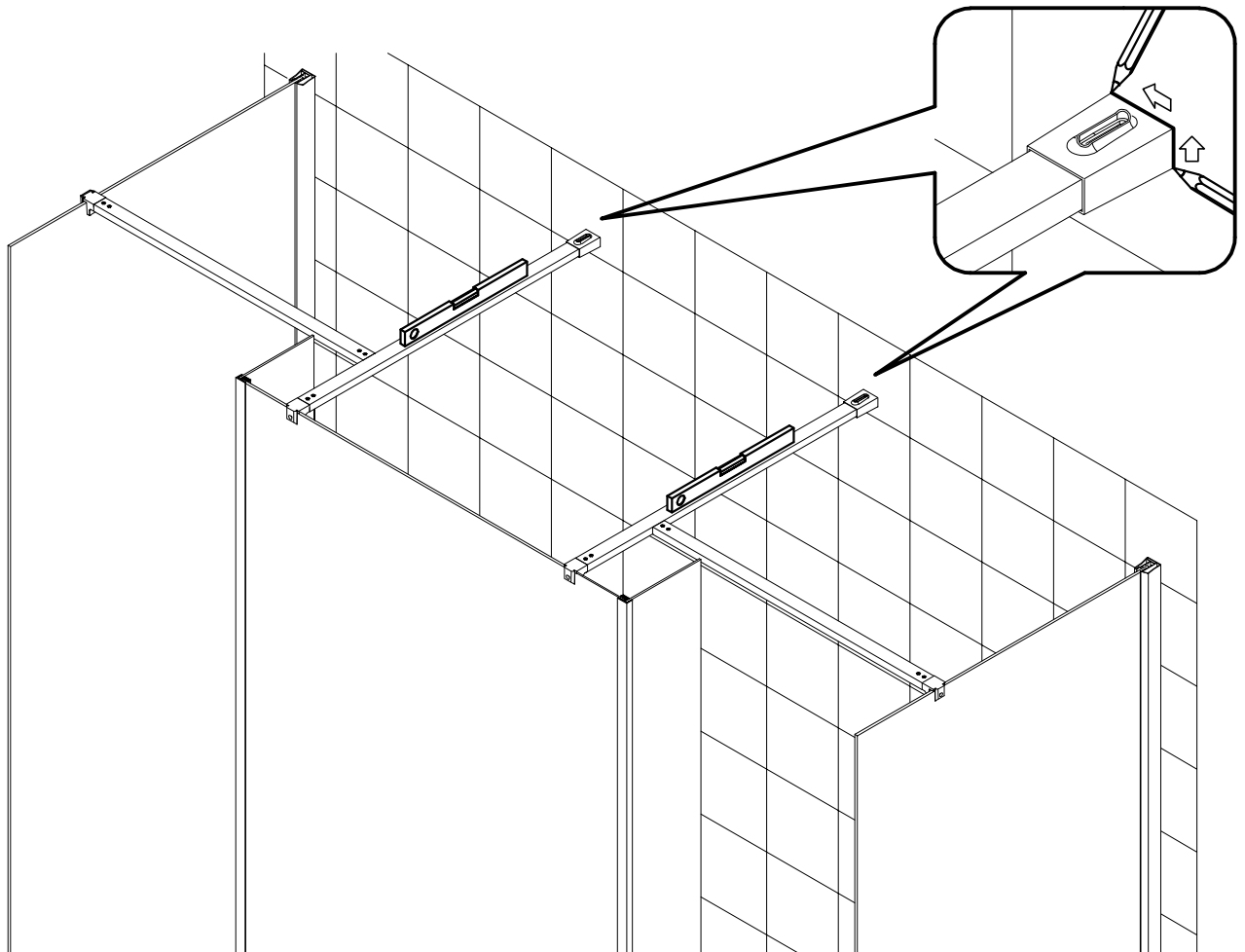

112

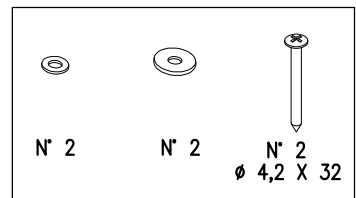
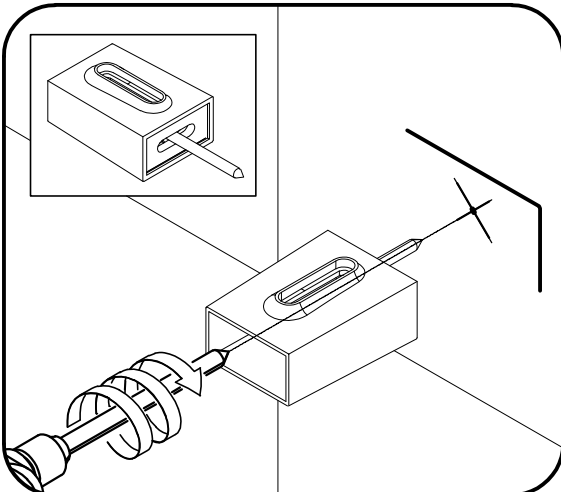
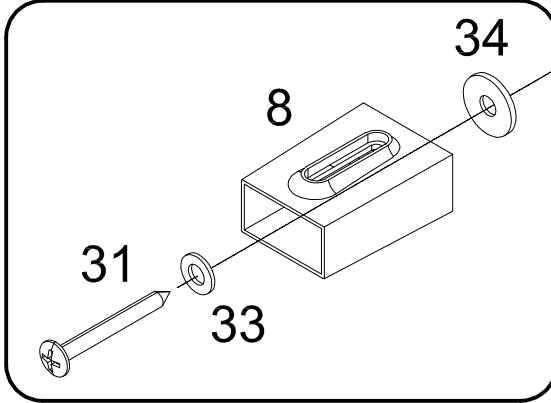
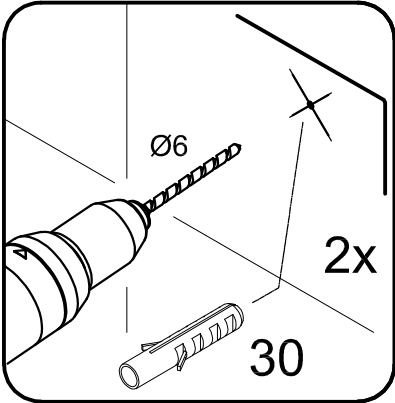
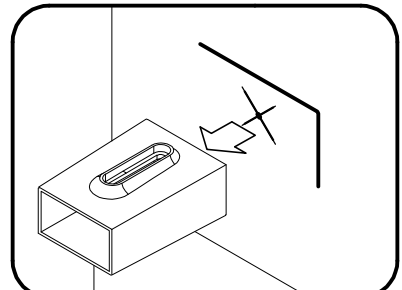
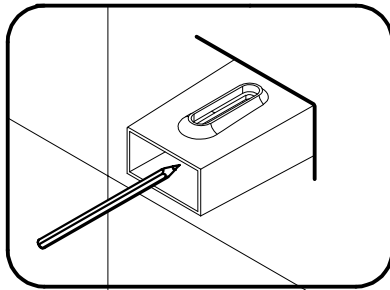
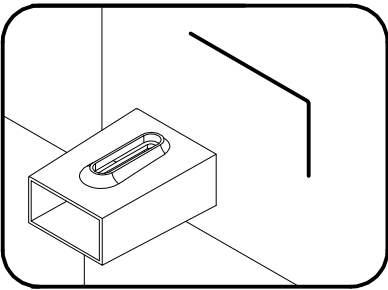
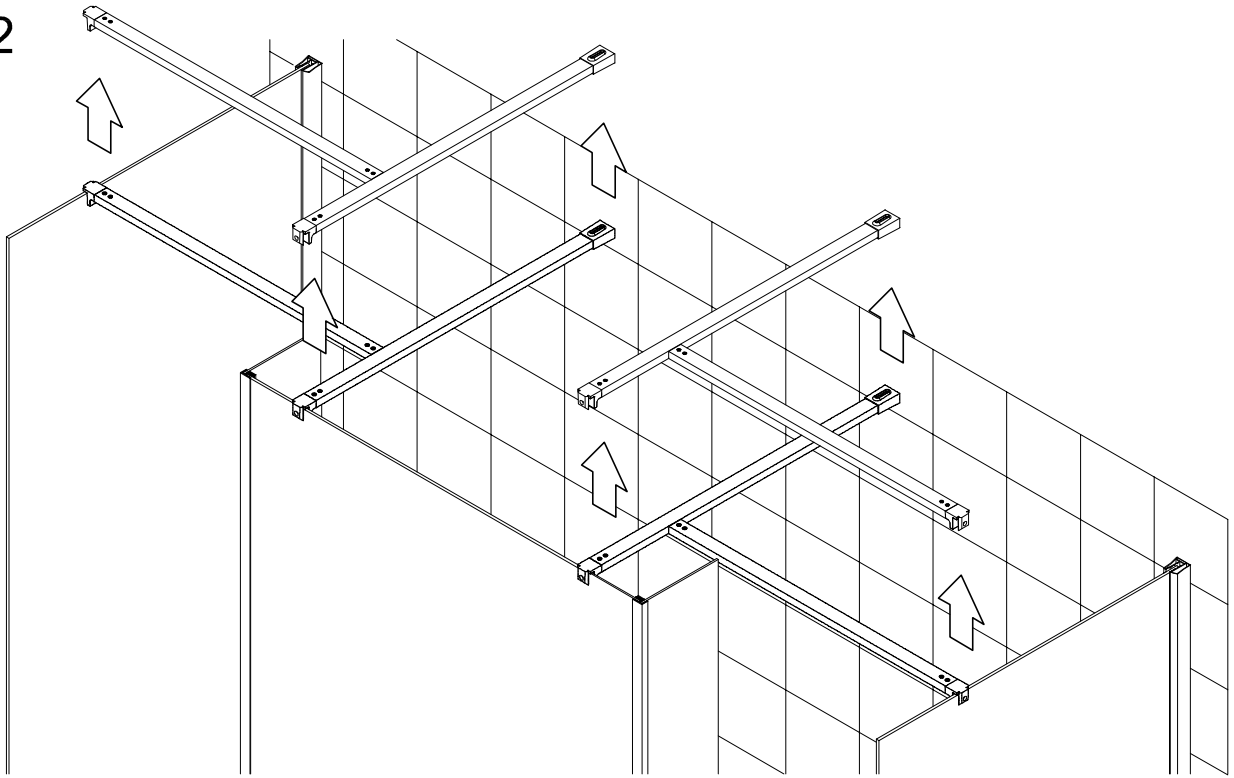

113

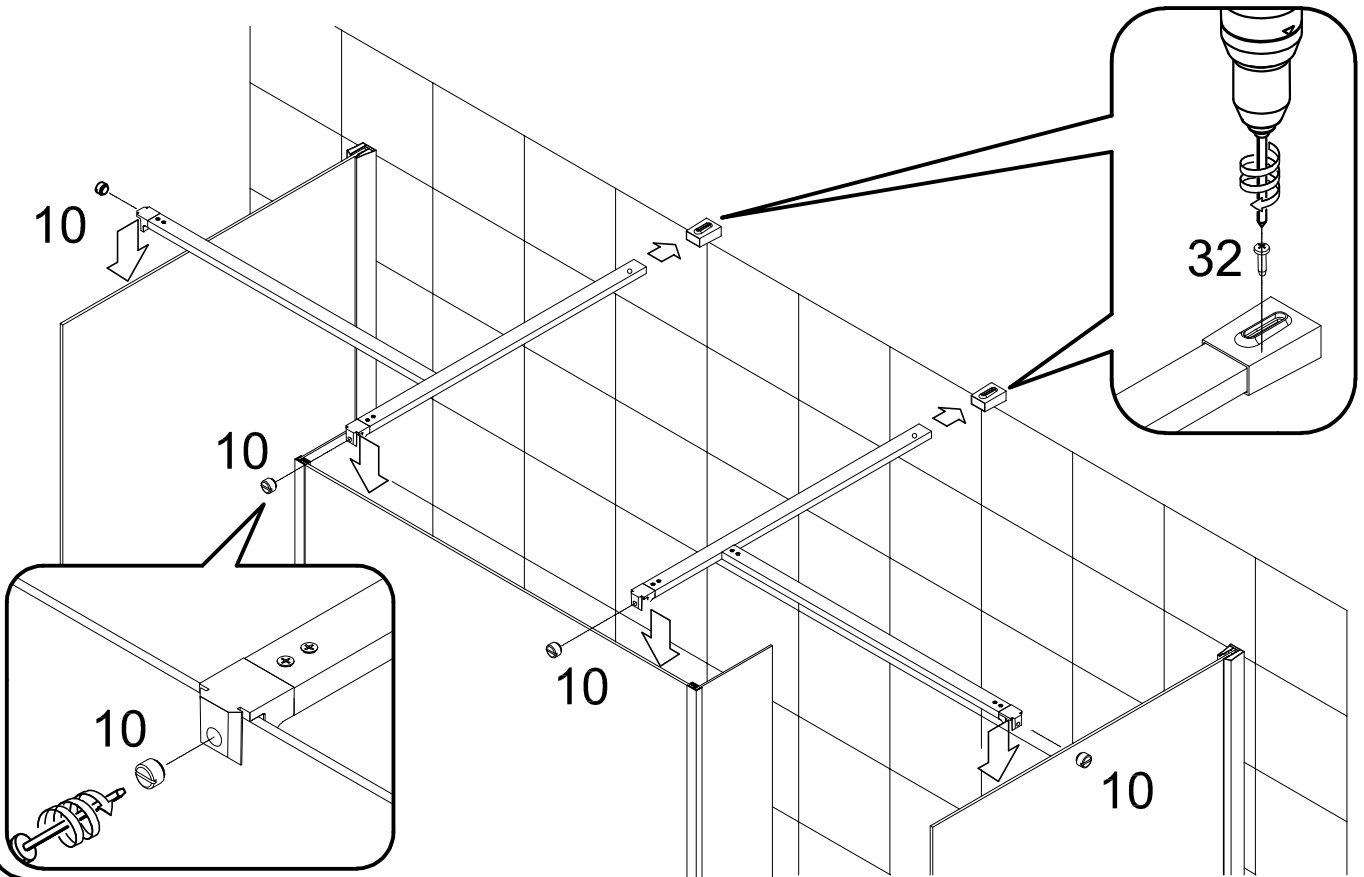

114

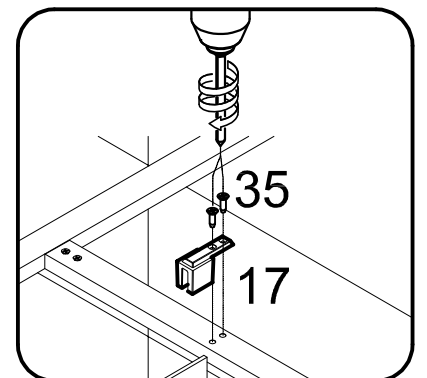
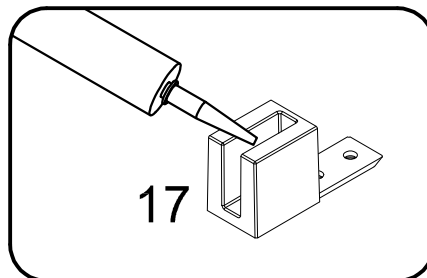
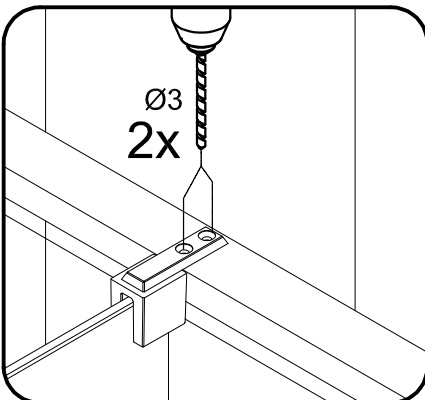
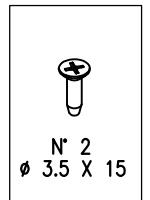
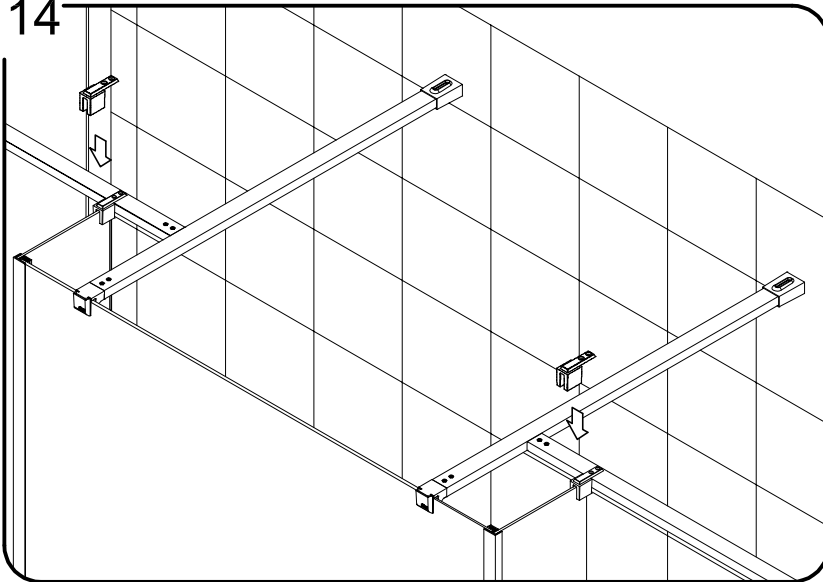

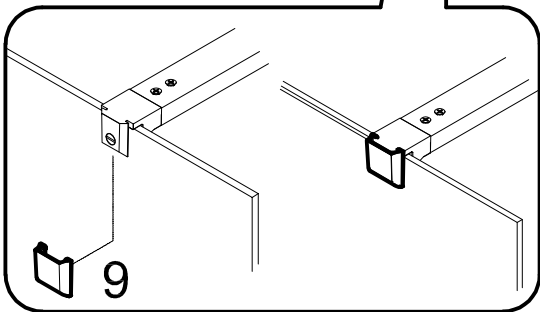
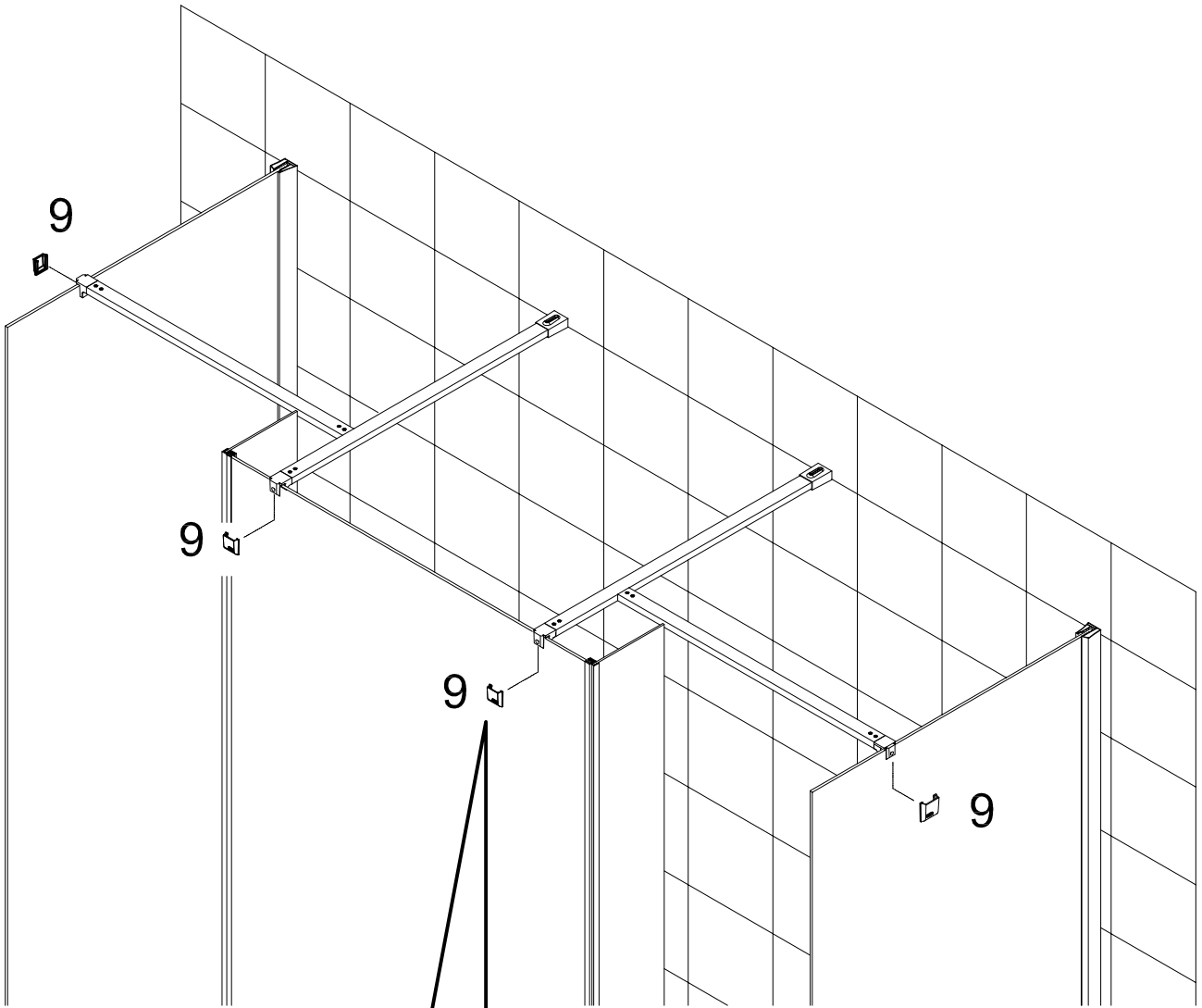



Pag. 1

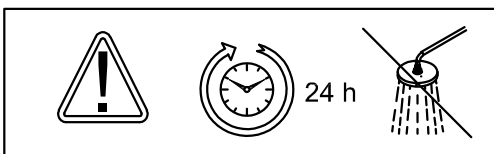
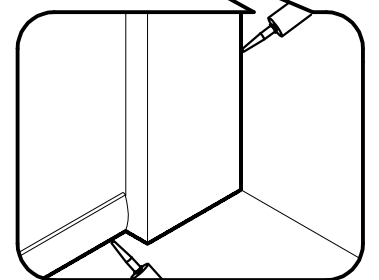
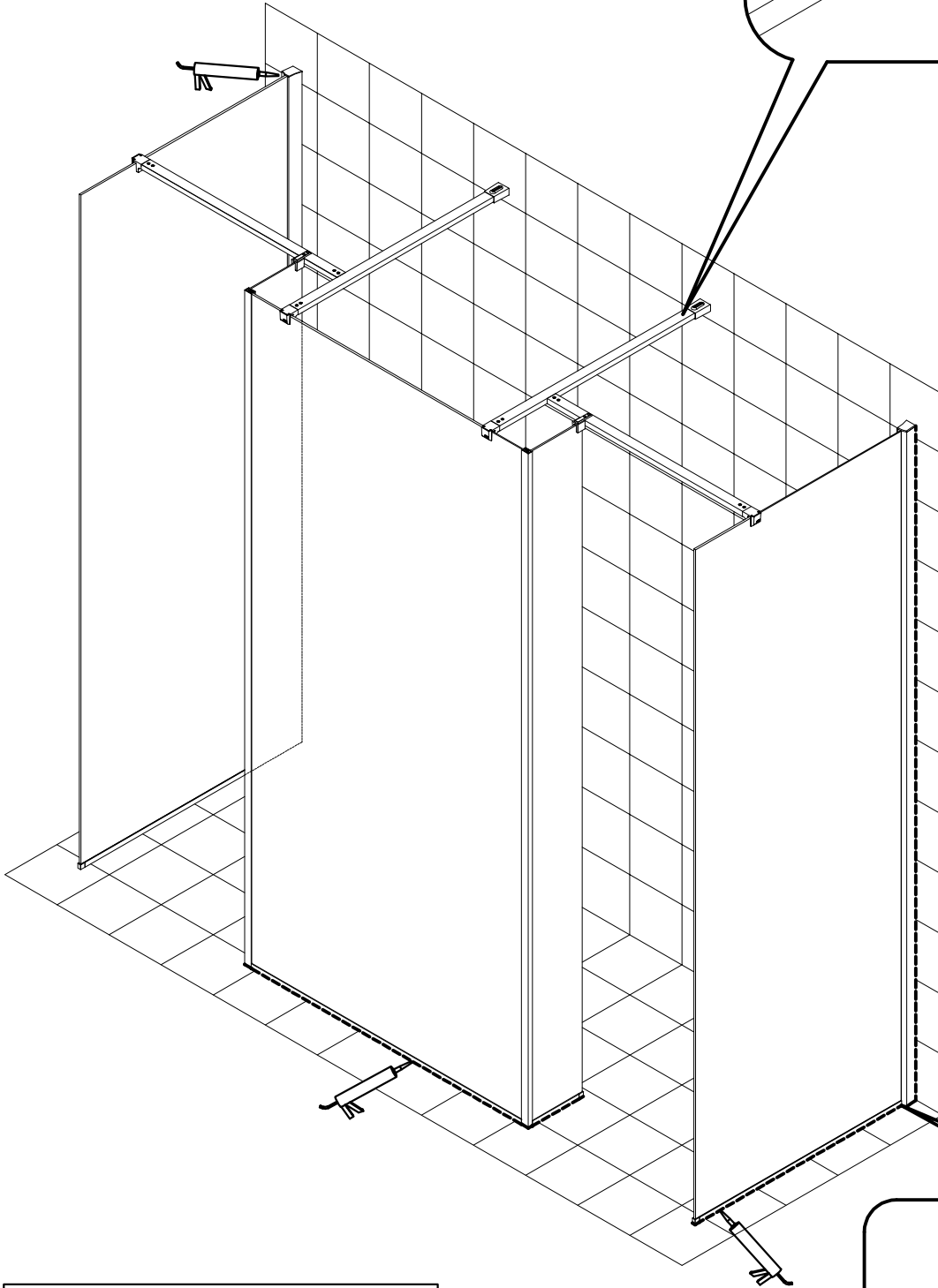
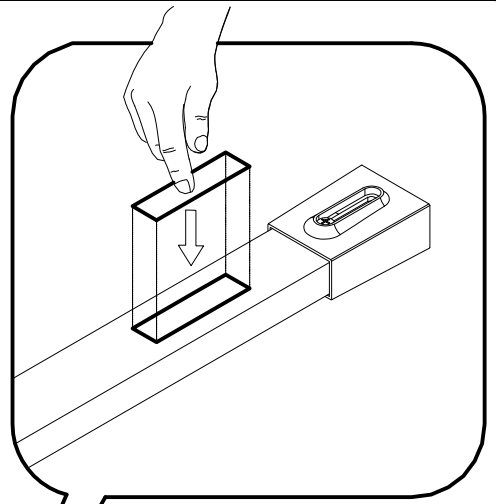
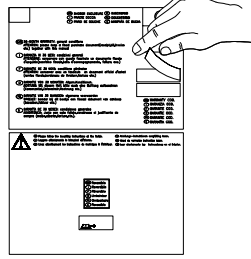



Customer care: tel +39 0363 38069 - fax +39 0363 380635

www.inda.net

- (GB) SHOWER ENCLOSURE (D) DUSCHWAND
 (I) PARETE DOCCIA (NL) DOUCHEWAND
 (F) PAROI DE DOUCHE (E) MAMPARA DE DUCHA



INDA - Via San Sisto, 3
I - 20123 Milano

Made in Via dell'industria, 41
I - 24040 Pagazzano (BG)

EN14428

(GB) 36-MONTH WARRANTY: general conditions
ATTENTION: please keep a fiscal purchase document(receipt,bill,invoice etc.) together with this manual

(I) GARANZIA DI 36 MESI: condizioni generali
ATTENZIONE: conservare con questo fascicolo un documento fiscale d'acquisto(scontrino fiscale,bolla d'accompagnamento, fattura ecc.)

(F) GARANTIE DE 36 MOIS: conditions générales
ATTENTION: conserver avec ce fascicule un document officiel d'achat (remise fiscale,bordereau de livraison,facture etc.)

(D) GARANTIE VON 36 MONATEN: Allgem.Konditionen.
ACHTUNG: Mit diesem Heft bitte auch eine Quittung aufbewahren (Kassenzettel,Lieferschein,Rechnung etc.)

(NL) GARANTIE VAN 36 MAANDEN: algemene voorwaarden
OPGELET: bewaar bij dit boekje een fiscaal dokument van aankoop (kassabon,faktuur etc.)

(E) GARANTÍA DE 36 MESES: condiciones generales
ADVERTENCIA: Junto con este folleto,consérvese el justificante de compra (recibo,albaràn,factura,etc.).

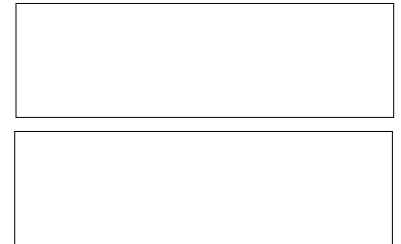

- (GB) WARRANTY COD.
 (I) GARANZIA COD.
 (F) GARANTIE COD.
 (D) GARANTIE COD.
 (NL) GARANTIE COD.
 (E) GARANTIA COD.



(GB) Please follow the mounting instructions at the inside.

(I) Leggere attentamente le istruzioni all'interno.

(F) Lisez attentivement les instructions de montages à l'intérieur.

(D) Anleitungs-instruktionen sorgfältig lesen.

(NL) Goed de vermelde instructies lezen.

(E) Leer atentamente las instrucciones en el interior.

- (GB) Reversible
 (I) Reversibile
 (F) Réversible
 (D) Umkehrbar
 (NL) Omkeerbare
 (E) Reversible

B2560B
B2561B

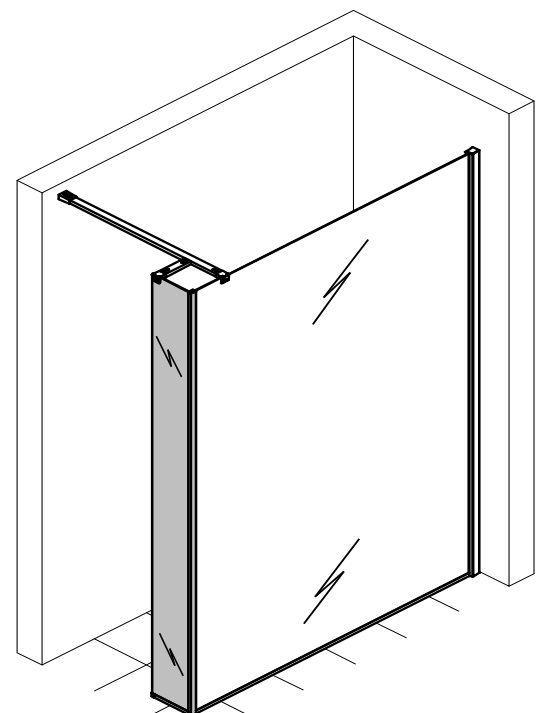
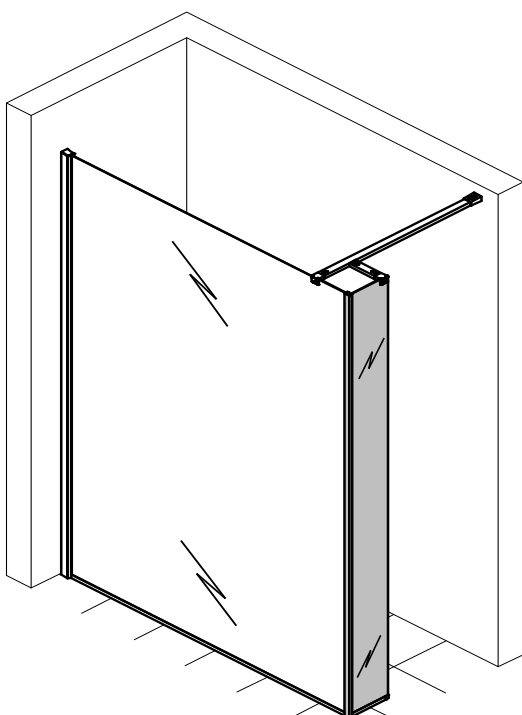

CE mark

The CE mark ensures and certifies that the shower enclosure wall, You have purchased, is produced in compliance with European standard EN 14428. The standard specifies requirements to ensure that the product, installed according to manufacturer's instructions and not tampered, provides satisfactory performance in use by the customer for personal hygiene. Before installation, make sure the shower enclosure wall has no breaks caused by transport, carefully check that each component has no evident defects. The manufacturer can not assume any liability for damages on a product already installed.

Maintenance

The water used in the plumbing systems contain calcium and magnesium salts which form hardness. The higher the hardness the greater the presence of limestone that is deposited on your shower wall, altering the appearance of glass, profiles and gaskets, or compromise the normal functioning of moving parts. To prevent the formation of limestone, we recommend to rinse and dry all surfaces of your shower enclosure walls after each use. Attention, the metals contained in water, the limestone and deposits of the detergents used for personal hygiene, could alter the colour of the gaskets. Slight traces of limestone can be removed using a solution of 1 / 3 water and 2 / 3 of vinegar or lemon, rub vigorously with a soft cloth, then rinse and dry. Treatment IGP is a technology used to protect the glass surfaces of the shower enclosure walls to facilitate daily cleaning. The duration IGP of treatment depends on the frequency of use of the shower enclosure, the water hardness and its maintenance, which must be carried out with appropriate products. To avoid deterioration of IGP treatment never use cleaning products with abrasive action, different kinds of solvents, alcohol, ammonia, bleach and aggressive acid / alkaline detergents (toilet cleaners, decalcifying products, degreasers, drain cleaners). To clean the glass treated with IGP and maintain over time the features, we recommend the use of the product specific IAGP (code B51600) available from our dealers.

Warranty

The guarantee must be exercised by a complaint to the manufacturer through the dealer from whom the shower enclosure wall has been purchased. The shower wall is guaranteed for 24 months (2 years) from date of purchase, which is evidenced by a receipt showing the name of the dealer. The guarantee will be extended for an additional 12 months (3 years total) to who will provide the "Guarantee COD"; the code is printed in double-adhesive label and pasted on the cover of this booklet. The warranty covers only operation flaws resulting from manufacturing defects. The eventual failure of the product must be checked and accepted by the manufacturer. The guarantee only commits the manufacturer to repair and / or replace defective components: is therefore ruled-out any further claim by the user.

The warranty is void if:

- The installation does not meet the installation instructions provided by the manufacturer.
- The operating flaws results from tampering or intervention unauthorized by the manufacturer.
- The malfunction is caused by abnormal wear of components due to negligence in the use and ordinary maintenance.

Marcatura CE

Il marchio CE assicura e certifica che la parete doccia, da Lei acquistata, è prodotta nel rispetto della norma europea EN 14428. La norma specifica i requisiti per garantire che il prodotto, installato in conformità alle istruzioni del fabbricante e non manomesso, fornisca prestazioni soddisfacenti durante l'uso da parte dell'utente per l'igiene personale. Prima dell'installazione, verificare che la parete doccia non abbia subito rotture causate dal trasporto, controllare attentamente che ogni suo componente sia privo di evidenti difetti. Il fabbricante non può assumersi alcuna responsabilità relativa a difetti su un prodotto già installato.

Manutenzione

L'acqua utilizzata negli impianti idrici contiene sali di calcio e di magnesio che ne costituiscono la durezza. Quanto più elevata è la durezza dell'acqua maggiore sarà la presenza di calcare che si deposita sulla vostra parete doccia, alterandone l'aspetto estetico di vetri, profili e guarnizioni o compromettendo il normale funzionamento delle parti in movimento. Per prevenire la formazione di calcare, consigliamo di risciacquare e asciugare tutte le superfici della vostra parete doccia, dopo ogni utilizzo. Attenzione, i metalli contenuti nell'acqua, il calcare e i depositi dei detersivi usati per l'igiene personale, potrebbero alterare il colore delle guarnizioni. Leggere tracce di calcare si possono rimuovere utilizzando una soluzione composta da 1/3 di acqua e 2/3 di aceto o di limone, strofinare energicamente con un panno morbido, quindi risciacquare ed asciugare. Il trattamento IGP è una tecnologia usata per la protezione delle superfici vetrate delle pareti doccia, per facilitare le operazioni di pulizia quotidiane. La durata del trattamento IGP dipende dalla frequenza d'uso della cabina doccia, dalla durezza dell'acqua e dalla relativa manutenzione, che deve essere effettuata con prodotti adeguati. Per evitare alterazioni del trattamento IGP non utilizzare assolutamente prodotti per la pulizia ad azione abrasiva, solventi di varia natura, alcool, ammoniaca, candeggina e detersivi aggressivi acidi/alcalini (pulitori per Wc, decalcificanti, sgrassatori, sturascarichi). Per pulire il vetro trattato con IGP e mantenerne nel tempo le caratteristiche, si consiglia l'utilizzo del prodotto specifico IAGP (cod. B51600) disponibile presso i nostri rivenditori.

Garanzia

La garanzia deve essere esercitata facendo reclamo, al fabbricante, tramite il rivenditore presso il quale è stata acquistata la parete doccia. La parete doccia è garantita per 24 mesi (2 anni) dalla data d'acquisto, comprovata da un documento fiscale che riporti il nominativo del rivenditore. La garanzia sarà prolungata di ulteriori 12 mesi (totale 3 anni) a chi fornirà il "Garanzia COD"; il codice è stampato in duplice etichetta adesiva e incollato sulla copertina di questo fascicolo. La garanzia copre esclusivamente vizi di funzionamento conseguenti a difetti di fabbricazione. L'eventuale non conformità del prodotto deve essere verificata e accettata dal fabbricante. La garanzia impegna il fabbricante solo alla riparazione e/o sostituzione dei componenti difettosi: è pertanto esclusa qualsiasi ulteriore pretesa da parte dell'utilizzatore.

La garanzia decade automaticamente quando:

- L'installazione non è conforme alle istruzioni di montaggio fornite dal fabbricante.
- Il vizio di funzionamento è conseguente a manomissione o a interventi non autorizzati dal fabbricante.
- Il funzionamento difettoso è causato da una usura anomala dei componenti dovuta a negligenza nell'uso e nell'ordinaria manutenzione.

Marquage CE

Le marquage CE assure et certifie que la paroi de douche que vous venez d'acheter a été produite dans le respect de la norme européenne EN 14428. La norme spécifie les qualités requises pour garantir que le produit, installé en conformité avec les instructions du fabricant, fournit des prestations satisfaisantes à l'utilisateur. Avant de procéder à l'installation, vérifier que la paroi de douche n'a subi aucun dommage durant son transport et contrôler attentivement que chaque composant soit exempt de tout défaut visible. Le fabricant ne peut être tenu responsable pour tout dommage portant sur un produit déjà installé.

Entretien

La dureté de l'eau utilisée dans les réseaux domestiques est relative à la présence de calcium et de magnésium. Plus la dureté de l'eau est élevée, plus importants seront les dépôts de calcaire sur votre paroi de douche, altérant ainsi l'aspect esthétique du verre, des profilés et des joints, et compromettant le bon fonctionnement de ses composantes mobiles. Afin de prévenir la formation de tartre, il est conseillé de rincer et d'essuyer toutes les surfaces de votre paroi de douche après chaque utilisation. Attention : les métaux et le calcaire contenus dans l'eau, ainsi que les résidus de détergents utilisés pour l'hygiène corporelle, pourraient altérer la couleur des joints. De légères traces de calcaire peuvent être éliminées en utilisant une solution composée pour 1/3 d'eau et 2/3 de jus de citron, en frottant énergiquement avec un chiffon doux avant de rincer et d'essuyer. Le traitement IGP est une technologie utilisée pour la protection des surfaces vitrées des parois de douche afin de faciliter les opérations de nettoyage quotidiennes. La durée du traitement IGP dépend de la dureté de l'eau, de la fréquence d'utilisation de la cabine de douche ainsi que de son entretien qui doit être effectué avec des produits adéquats. Pour éviter d'altérer le traitement IGP, n'utiliser en aucun cas des produits de nettoyage abrasifs, des solvants, de l'alcool, de l'ammoniaque, de l'eau de javel et des détergents agressifs acides/alcalins (produits WC, anticalcaires, dégraissants, déboucheurs de canalisations, ...). Pour nettoyer le verre traité avec l'IGP et en prolonger l'efficacité, il est conseillé d'utiliser le produit spécifique IAGP (référence B51600) disponible auprès de votre revendeur.

Garantie

La garantie est opposable au fabricant au travers du revendeur chez qui vous avez acheté le produit. La paroi de douche est garantie pour une période de 24 mois (2 ans) à partir de la date d'achat justifiée par la facture faisant figurer le nom du revendeur. La garantie sera prolongée de 12 mois (soit 3 ans au total) à qui fournira le « code de garantie » ; le code est imprimé sur deux étiquettes adhésives collées sur la couverture du présent document. La garantie couvre exclusivement les vices de fonctionnement consécutifs à des défauts de fabrication. L'éventuelle non-conformité du produit doit être vérifiée et acceptée par le fabricant. La garantie engage uniquement le fabricant à la réparation et/ou la substitution des composants défectueux : de ce fait, sont exclues toutes poursuites ultérieures de la part de l'utilisateur.

La garantie devient caduque si :

- L'installation n'est pas conforme aux instructions de montage fournies par le fabricant.
- Le vice de fonctionnement est consécutif à une utilisation non conforme du produit ou à une intervention non autorisée par le fabricant.
- Le fonctionnement défectueux est causé par une usure anormale des composants due à une négligence tant au niveau de l'utilisation que de l'entretien.

D**CE - Kennzeichnung**

Die CE – Kennzeichnung gewährleistet und bestätigt, dass die von Ihnen bestellte Duschatbrennung gemäß der europäischen Richtlinie EN14428 hergestellt wurde. Diese Richtlinie beschreibt die Erfordernisse, die gewährleisten, dass das Produkt, welches gemäß den Montageanweisungen des Lieferanten und nicht beschädigt montiert wurde, befriedigende Leistungen während des Gebrauchs durch den Endkunden für dessen Körperpflege bringt. Vor der Installation prüfen Sie bitte, dass die Duschatbrennung während des Transports nicht beschädigt wurde und dass die Bestandteile nicht deutlich mangelhaft sind. Der Hersteller wird keine Verantwortung für Schäden an eines bereits installierten Produktes übernehmen.

Pflege

Das Wasser, das in den Wasserleitungen benutzt wird, enthält Kalzium- und Magnesiumsalze, die die Wasserstärke bestimmen.

Je höher die Wasserstärke ist, desto höher wird die Kalksteinkonzentration sein; der Kalkstein lagert sich an der Duschatbrennung an, und verändert dadurch die Ästhetik der Gläser, der Rahmen und Dichtungen und ändert, beeinträchtigt das übliche Funktionieren der beweglichen Teile.

Um die Bildung des Kalksteins zu verhindern, empfehlen wir Ihnen, die gesamten Oberflächen der Duschatbrennung nach jeder Verwendung zu spülen und zu trocknen.

Achtung! Die Metalle, die im Wasser enthalten sind, der Kalkstein und die Ablagerungen der Körperreinigungsmittel könnten die Farbe der Dichtungen ändern.

Leichte Kalkspuren können durch eine Lösung, 1/3 Liter Wasser und 2/3 Liter Essig oder Zitrone, entfernt werden, mit einem weichen Tuch energisch reiben, danach spülen und abtrocknen.

Die IGP Behandlung ist eine Technologie, die für den Schutz der Glasoberflächen der Duschatbrennungen benutzt wird, damit die tägliche Reinigung erleichtert wird.

Die Dauer der IGP Behandlung hängt von der Häufigkeit der Benutzung der Duschatbrennung, von der Wasserstärke und von der entsprechenden Pflege ab. Sie muss mit den angemessenen Mittel durchgeführt werden. Um Veränderungen der IGP Behandlung zu vermeiden, bitten wir Sie keine scheuernden Reinigungsmittel, keine Lösemittel, Alkohol, Ammoniak, Bleichlauge und starke, saure, alkalische Reinigungsmittel (WC Reiniger, Entkalker, Entfetter, Ausgusspüler) zu verwenden.

Um das mit IGP beschichtete Glas zu reinigen und die Eigenschaften lange zu erhalten, empfehlen wir Ihnen das spezielle Produkt IAGP (Kode B51600) zu verwenden; das Produkt ist bei unseren Verkäufern verfügbar.

Der mögliche Mangel muss vom Hersteller geprüft und akzeptiert werden.

Die Gewährleistung verpflichtet den Hersteller die mangelhaften Teile zu reparieren bzw. zu ersetzen; jede weitere Forderung des Endkunden ist von daher ausgeschlossen.

Gewährleistung

Der Garantieanspruch muss durch eine schriftliche Reklamation an Hersteller durch den Verkäufer, wo die Duschatbrennung bestellt wurde, erfolgen.

Die Duschatbrennung hat eine Garantielaufzeit von 24 Monaten (2 Jahre) ab Bestelldatum; diese Laufzeit wird durch eine ordentliche Rechnung mit den Stammdaten des Verkäufers bestätigt.

Die Gewährleistung wird durch eine "Garanzia COD" für weitere 12 Monate (insgesamt 3 Jahre) verlängert; die Kode wird auf einer zweifachen Aufklebeetikette gedruckt und an dem Deckel dieses Hefts geklebt. Die Gewährleistung deckt nur Funktionsfehler, die durch die Produktionsfehler verursacht wurden.

Der mögliche Mangel muss vom Hersteller geprüft und akzeptiert werden.

Die Gewährleistung verpflichtet den Hersteller die mangelhaften Teile zu reparieren bzw. zu ersetzen; jede weitere Forderung des Endkunden ist von daher ausgeschlossen.

Die Gewährleistung erlischt automatisch, wenn:

- Die Installation nicht gemäß der Montageanweisungen des Herstellers durchgeführt wurde.
- Der Funktionsfehler eine Konsequenz eines unsachgemäßen Einwirkens oder von Reparaturen, die vom Hersteller nicht genehmigt wurden, ist.
- Das fehlerhafte Funktionieren von einer anormalen Abnutzung der Komponenten wegen Nachlässigkeit beim Gebrauch oder bei der Pflege verursacht wurde.

NL**CE Merking**

Het merk CE garandeert en verklaart dat de door u gekochte douchewand geproduceerd is in naleving van de Europese norm EN 14428. De norm beschrijft in gedetailleerde vorm de vereisten om te garanderen dat het product, geïnstalleerd volgens de instructies van de fabrikant zonder te forceren, bevredigende prestaties levert tijdens het gebruik door de gebruiker voor de persoonlijke hygiëne. Vóór de installatie moet onderzocht worden of de douchewand geen beschadigingen heeft opgelopen die veroorzaakt zijn door transport en moet met aandacht gecontroleerd worden of ieder onderdeel geen zichtbare defecten heeft. De fabrikant kan de verantwoordelijkheid van beschadigingen op een product die al geïnstalleerd is, niet op zich nemen.

Onderhoud

Het water dat gebruikt wordt in de waterleiding bevat kalkzouten en magnesiumzouten die hiervan de hardheid bepalen.

Hoe harder het water, hoe meer kalksteen aanwezig zal zijn en achter zal blijven op uw douchewand om zo de uitstraling van het glas, van de profielen en van de strippen aan te tasten of de normale werking van de bewegings componenten te schaden.

Om de vorming van kalksteen tegen te gaan, adviseren wij u om na gebruik al de oppervlakten van uw douchecabine af te spoelen en af te drogen.

Opgelet, de metalen in het water, de kalksteen en de resten van reinigingsmiddelen die gebruikt zijn voor de persoonlijke hygiëne, kunnen de kleur van de strippen aantasten.

Lichte kalksteenresten kunnen verwijderd worden door te wrijven met een mengsel van 1/3 water en 2/3 azijn of citroen op een zachte doek, vervolgens afspoelen en afdrogen.

De IGP behandeling is een technologie die gebruikt wordt om de oppervlakten van glas te beschermen en om de dagelijkse schoonmaakactiviteiten te vergemakkelijken.

De duur van de behandeling IGP hangt af van hoeveel de douchecabine gebruikt wordt, van de hardheid van het water en van het desbetreffende onderhoud die met de juiste producten verricht moet worden. Om aantastingen van de IGP behandeling te voorkomen moeten absoluut geen schoonmaakmiddelen gebruikt worden met schuummiddel, oplosmiddelen van verschillende oorsprong, alcohol, ammoniak, bleekmiddel en agressieve, zure/basische schoonmaakmiddelen (middelen voor de wc, antikalkmiddelen, ontvetters, ontstoppers).

Om het glas met IGP behandeling schoon te maken en de eigenschappen ervan in de tijd te behouden, adviseren wij u om het specifieke product IAGP te gebruiken (code B51600), dat beschikbaar is in onze verkooppunten.

Garantie

U kunt zich beroepen op de garantie door een klachtmelding te sturen naar de fabrikant door middel van het verkooppunt waar u de douchewand heeft gekocht.

De garantie op de douchewand is geldig voor 24 maanden (2 jaar) vanaf de aankoop datum, bewezen met een fiscaal document waarop de naam van het verkooppunt is weergegeven.

De garantie wordt verlengd voor andere 12 maanden (in totaal 3 jaar) aan wie voorzien is van de "Garantie COD"; de code staat geprint op twee etiketten en is op het voorblad van deze folder gelijmd. De garantie dekt alleen gebreken in de functionering, veroorzaakt door productiefouten. Indien het product eventueel niet conform is, moet dit onderzocht en geaccepteerd worden door de fabrikant.

De garantie verplicht de fabrikant alleen tot de reparatie en/of vervanging van de defecte onderdelen: welke eis dan ook van de gebruiker is derhalve uitgesloten.

De garantie verloopt automatisch wanneer:

- De installatie niet overeenkomt met de montage instructies verschaft door de fabrikant.
- Het functioneringsdefect een gevolg is van forceren of een ingrijpen dat niet geautoriseerd is door de fabrikant.
- Het functioneringsdefect veroorzaakt is door een anormale slijtage van de componenten door nalatigheid in het gebruik en in het dagelijks onderhoud.

E**Marca CE**

La marca CE asegura y certifica que la pared ducha, comprada por Usted, fue producida respetando la norma europea EN 14428.

La norma específica los requisitos para garantizar que el producto, instalado en conformidad con las instrucciones del fabricante y no manipulado, suministre prestaciones satisfactorias durante el uso por parte del consumidor para la higiene personal.

Antes de la instalación, verificar que la pared de ducha no haya sufrido daños causados por el transporte, controlar atentamente que cada componente no tenga defectos evidentes.

El fabricante no puede asumir responsabilidad alguna cuando un producto haya sido ya instalado.

Manutención

El agua utilizada en los implantes hidráulicos contiene sal de calcio y de magnesio, los cuales constituyen su dureza.

Más elevada es la dureza del agua, mayor es la presencia de cal que se deposita en vuestra pared de ducha, alterando el aspecto estético de los vidrios, perfiles y guarniciones, o comprometiendo el normal funcionamiento de las partes móviles.

Para prevenir la formación de cal, aconsejamos enjuagar y secar todas las superficies de vuestra pared de ducha, después de cada uso. Atención, que entre los metales y la cal contenidos en el agua y los restos de detergentes usados para la higiene personal, se podría alterar el color de la guarnición.

Los restos de cal se pueden remover usando una solución compuesta por 1/3 de agua y 2/3 de vinagre o limón, limpiando energicamente con un trapo húmedo, posteriormente enjuagar y secar.

El tratamiento IGP es la tecnología usada para la protección de las superficies vidriadas de las paredes de ducha, para facilitar la operación de limpieza cotidiana.

La duración del tratamiento IGP depende della frecuencia del uso dado a la mampara de ducha, de la dureza del agua y de la relativa manutención, que debe efectuarse con productos adecuados. Para evitar alteraciones del tratamiento IGP no utilizar absolutamente productos de limpieza abrasivos, solventes varios, alcohol, amoniaca, lejía y detergentes agresivos ácidos/alcalinos (limpiadores de WC, descalcificantes, desengrasantes, destapacañerías). Para limpiar el vidrio tratado con IGP y mantener a lo largo del tiempo sus características, se aconseja el uso del producto específico IAGP (cód. B51600) disponible a través de nuestros revendedores.

Para prevenir la formación de cal, aconsejamos enjuagar y secar todas las superficies de vuestra pared de ducha, después de cada uso. Atención, que entre los metales y la cal contenidos en el agua y los restos de detergentes usados para la higiene personal, se podría alterar el color de la guarnición.

Los restos de cal se pueden remover usando una solución compuesta por 1/3 de agua y 2/3 de vinagre o limón, limpiando energicamente con un trapo húmedo, posteriormente enjuagar y secar.

El tratamiento IGP es la tecnología usada para la protección de las superficies vidriadas de las paredes de ducha, para facilitar la operación de limpieza cotidiana.

La duración del tratamiento IGP depende della frecuencia del uso dado a la mampara de ducha, de la dureza del agua y de la relativa manutención, que debe efectuarse con productos adecuados. Para evitar alteraciones del tratamiento IGP no utilizar absolutamente productos de limpieza abrasivos, solventes varios, alcohol, amoniaca, lejía y detergentes agresivos ácidos/alcalinos (limpiadores de WC, descalcificantes, desengrasantes, destapacañerías). Para limpiar el vidrio tratado con IGP y mantener a lo largo del tiempo sus características, se aconseja el uso del producto específico IAGP (cód. B51600) disponible a través de nuestros revendedores.

Para prevenir la formación de cal, aconsejamos enjuagar y secar todas las superficies de vuestra pared de ducha, después de cada uso. Atención, que entre los metales y la cal contenidos en el agua y los restos de detergentes usados para la higiene personal, se podría alterar el color de la guarnición.

Los restos de cal se pueden remover usando una solución compuesta por 1/3 de agua y 2/3 de vinagre o limón, limpiando energicamente con un trapo húmedo, posteriormente enjuagar y secar.

El tratamiento IGP es la tecnología usada para la protección de las superficies vidriadas de las paredes de ducha, para facilitar la operación de limpieza cotidiana.

La duración del tratamiento IGP depende della frecuencia del uso dado a la mampara de ducha, de la dureza del agua y de la relativa manutención, que debe efectuarse con productos adecuados. Para evitar alteraciones del tratamiento IGP no utilizar absolutamente productos de limpieza abrasivos, solventes varios, alcohol, amoniaca, lejía y detergentes agresivos ácidos/alcalinos (limpiadores de WC, descalcificantes, desengrasantes, destapacañerías). Para limpiar el vidrio tratado con IGP y mantener a lo largo del tiempo sus características, se aconseja el uso del producto específico IAGP (cód. B51600) disponible a través de nuestros revendedores.

Para prevenir la formación de cal, aconsejamos enjuagar y secar todas las superficies de vuestra pared de ducha, después de cada uso. Atención, que entre los metales y la cal contenidos en el agua y los restos de detergentes usados para la higiene personal, se podría alterar el color de la guarnición.

Los restos de cal se pueden remover usando una solución compuesta por 1/3 de agua y 2/3 de vinagre o limón, limpiando energicamente con un trapo húmedo, posteriormente enjuagar y secar.

El tratamiento IGP es la tecnología usada para la protección de las superficies vidriadas de las paredes de ducha, para facilitar la operación de limpieza cotidiana.

La duración del tratamiento IGP depende della frecuencia del uso dado a la mampara de ducha, de la dureza del agua y de la relativa manutención, que debe efectuarse con productos adecuados. Para evitar alteraciones del tratamiento IGP no utilizar absolutamente productos de limpieza abrasivos, solventes varios, alcohol, amoniaca, lejía y detergentes agresivos ácidos/alcalinos (limpiadores de WC, descalcificantes, desengrasantes, destapacañerías). Para limpiar el vidrio tratado con IGP y mantener a lo largo del tiempo sus características, se aconseja el uso del producto específico IAGP (cód. B51600) disponible a través de nuestros revendedores.

Para prevenir la formación de cal, aconsejamos enjuagar y secar todas las superficies de vuestra pared de ducha, después de cada uso. Atención, que entre los metales y la cal contenidos en el agua y los restos de detergentes usados para la higiene personal, se podría alterar el color de la guarnición.

Los restos de cal se pueden remover usando una solución compuesta por 1/3 de agua y 2/3 de vinagre o limón, limpiando energicamente con un trapo húmedo, posteriormente enjuagar y secar.

El tratamiento IGP es la tecnología usada para la protección de las superficies vidriadas de las paredes de ducha, para facilitar la operación de limpieza cotidiana.

La duración del tratamiento IGP depende della frecuencia del uso dado a la mampara de ducha, de la dureza del agua y de la relativa manutención, que debe efectuarse con productos adecuados. Para evitar alteraciones del tratamiento IGP no utilizar absolutamente productos de limpieza abrasivos, solventes varios, alcohol, amoniaca, lejía y detergentes agresivos ácidos/alcalinos (limpiadores de WC, descalcificantes, desengrasantes, destapacañerías). Para limpiar el vidrio tratado con IGP y mantener a lo largo del tiempo sus características, se aconseja el uso del producto específico IAGP (cód. B51600) disponible a través de nuestros revendedores.

Para prevenir la formación de cal, aconsejamos enjuagar y secar todas las superficies de vuestra pared de ducha, después de cada uso. Atención, que entre los metales y la cal contenidos en el agua y los restos de detergentes usados para la higiene personal, se podría alterar el color de la guarnición.

Los restos de cal se pueden remover usando una solución compuesta por 1/3 de agua y 2/3 de vinagre o limón, limpiando energicamente con un trapo húmedo, posteriormente enjuagar y secar.

El tratamiento IGP es la tecnología usada para la protección de las superficies vidriadas de las paredes de ducha, para facilitar la operación de limpieza cotidiana.

La duración del tratamiento IGP depende della frecuencia del uso dado a la mampara de ducha, de la dureza del agua y de la relativa manutención, que debe efectuarse con productos adecuados. Para evitar alteraciones del tratamiento IGP no utilizar absolutamente productos de limpieza abrasivos, solventes varios, alcohol, amoniaca, lejía y detergentes agresivos ácidos/alcalinos (limpiadores de WC, descalcificantes, desengrasantes, destapacañerías). Para limpiar el vidrio tratado con IGP y mantener a lo largo del tiempo sus características, se aconseja el uso del producto específico IAGP (cód. B51600) disponible a través de nuestros revendedores.

Para prevenir la formación de cal, aconsejamos enjuagar y secar todas las superficies de vuestra pared de ducha, después de cada uso. Atención, que entre los metales y la cal contenidos en el agua y los restos de detergentes usados para la higiene personal, se podría alterar el color de la guarnición.

Los restos de cal se pueden remover usando una solución compuesta por 1/3 de agua y 2/3 de vinagre o limón, limpiando energicamente con un trapo húmedo, posteriormente enjuagar y secar.

El tratamiento IGP es la tecnología usada para la protección de las superficies vidriadas de las paredes de ducha, para facilitar la operación de limpieza cotidiana.

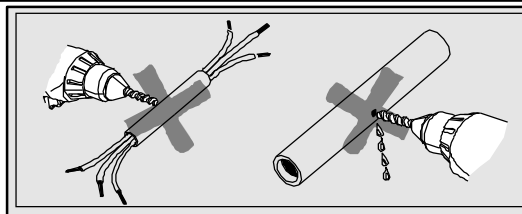

GB Warning! before proceeding to drill the walls, make sure that there are no electrical wires or pipes water / gas; Also check if the attachment dowels, included in the equipment, are suitable for the wall structure to be drilled, if necessary replace them.

I Attenzione! prima di procedere alla foratura delle pareti, accertarsi che non siano presenti cavi elettrici o tubi acqua/gas; Inoltre verificare se i tasselli di fissaggio, forniti in dotazione, sono idonei alla struttura muraria da forare, se necessario sostituirli.

F Attention ! avant de procéder au perçage des murs, vérifier qu'ils ne recèlent pas de conduits électriques, d'eau ou de gaz. De plus, vérifier que les vis de fixation, fournies dans le colis, sont adéquates par rapport à la structure du mur à percer et, le cas échéant, les substituer.

D Achtung! Bevor Sie in die Wände bohren, stellen Sie bitte fest, dass keine Stromkabel, Wasser- oder Gasleitungen vorhanden sind; außerdem prüfen Sie bitte, ob die Befestigungsdübel, die sich in der Verpackung befinden, für die Wand, die angebohrt werden soll, geeignet sind. Wenn notwendig, bitte austauschen.

NL Opgelet! Voordat er overgegaan kan worden tot het boren in de wanden, moet u ervan verzekerd zijn dat er geen elektrische draden of water/gaspijpen aanwezig zijn; bovendien moet er onderzocht worden of de bevestigingspluggen, die bij de uitrusting behoren, geschikt zijn voor de structuur van de wand die geboord moet worden. Indien noodzakelijk moeten deze vervangen worden.

E Atención! Antes de proceder a agujerear las paredes, asegurarse que no hubiesen cables eléctricos o tuberías de agua/gas; Además, verificar que los tornillos de fijación, suministrados en dotación, sean idóneos para la estructura del muro a perforar, y si fuese necesario, sustituirlos.

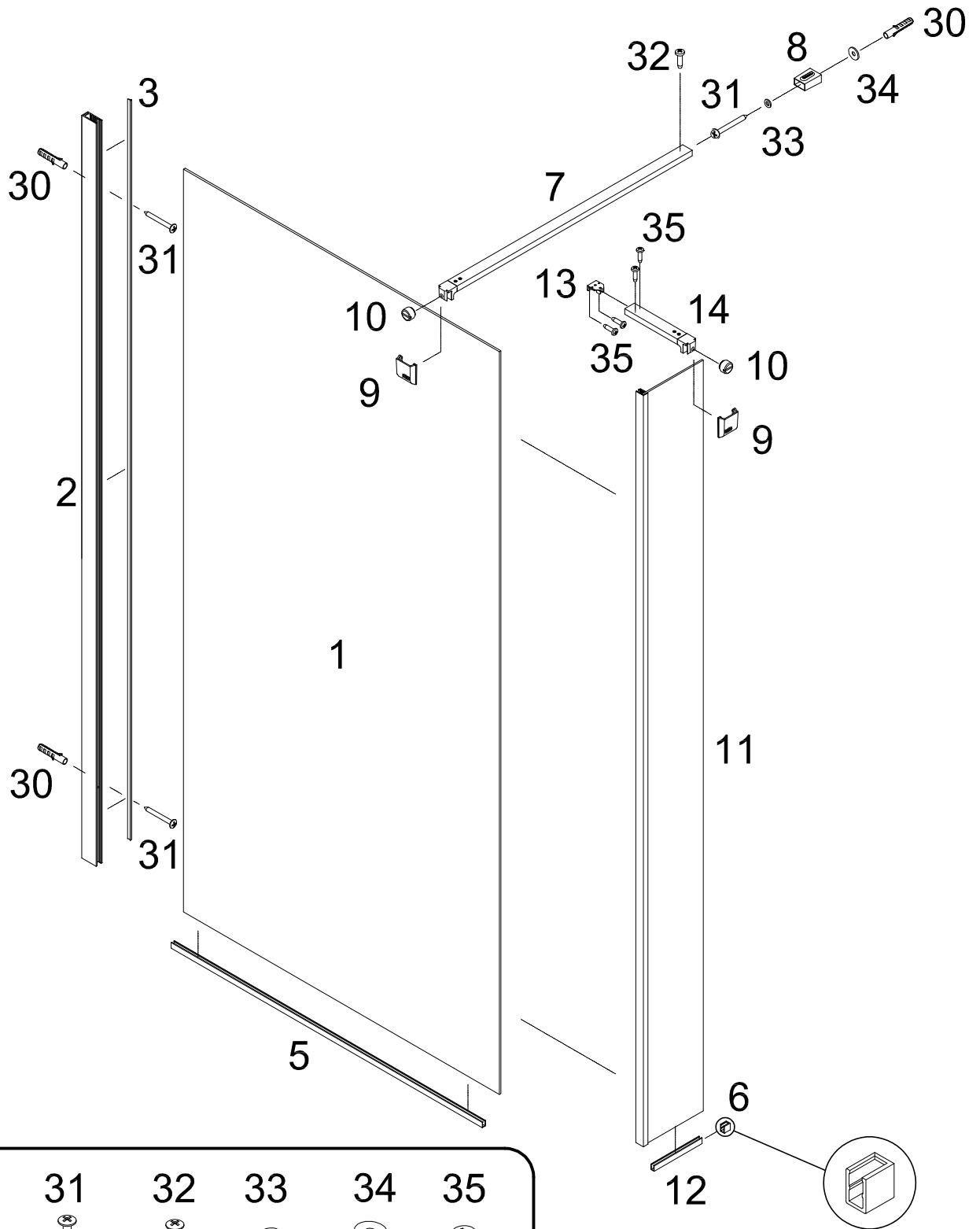

- | | | | | | |
|------------------|--------------------|--------------------|------|------|--------------------|
| 30 | 31 | 32 | 33 | 34 | 35 |
| | | | | | |
| N° 3
Ø 6 X 30 | N° 3
Ø 4,2 X 32 | N° 1
Ø 3,5 X 13 | N° 1 | N° 1 | N° 4
Ø 3,5 X 13 |

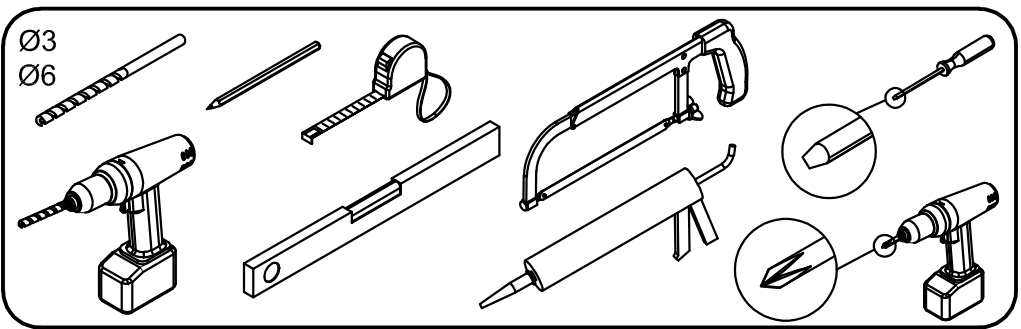
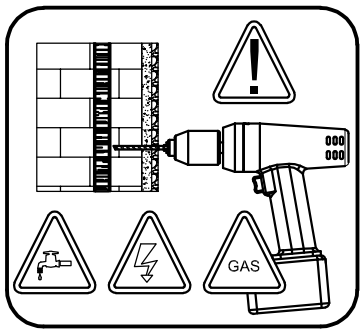

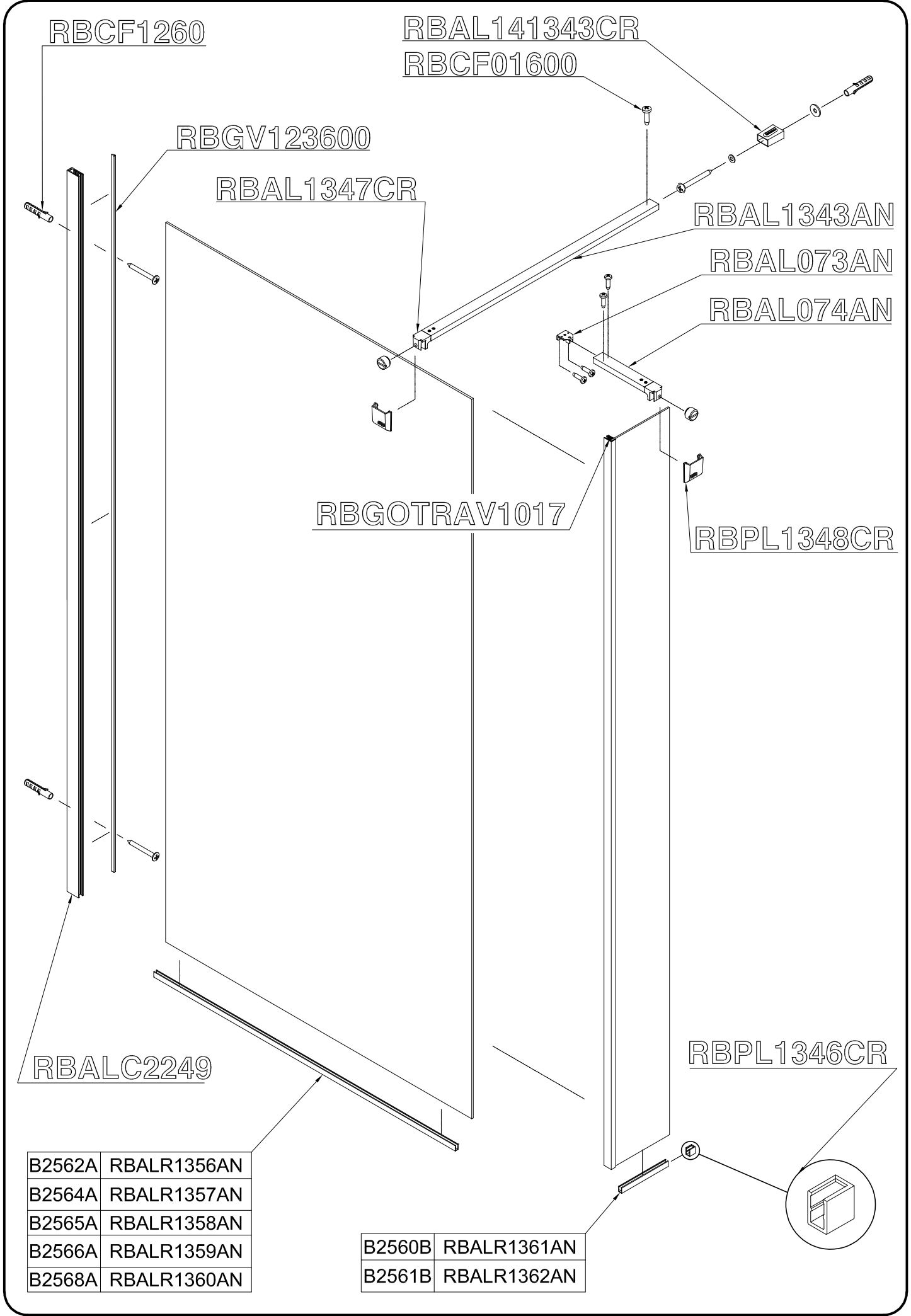

B2562A	RBALR1356AN
B2564A	RBALR1357AN
B2565A	RBALR1358AN
B2566A	RBALR1359AN
B2568A	RBALR1360AN

B2560B	RBALR1361AN
B2561B	RBALR1362AN

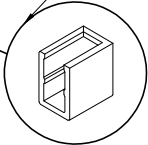

RBAL1343AN

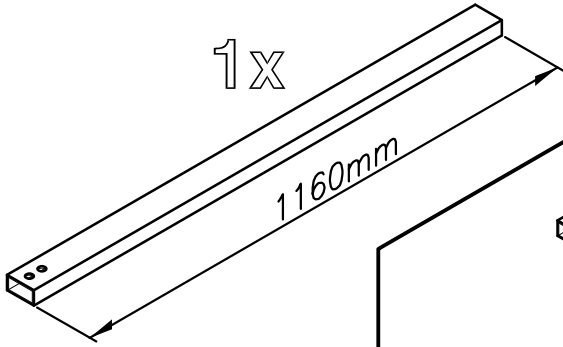

RBAL074AN

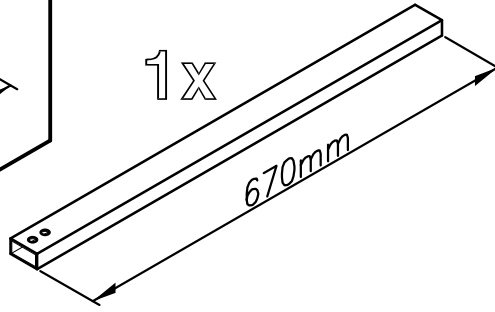

RBAL073AN

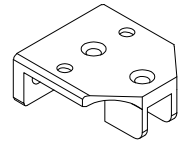

1x

RBALC2249

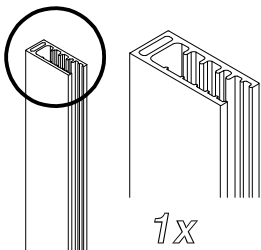

RBCF01600

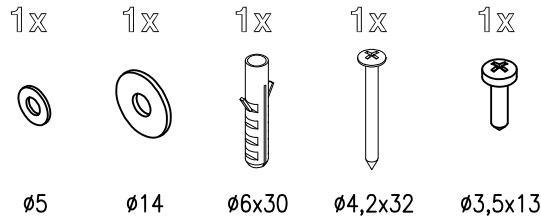

RBAL141343CR

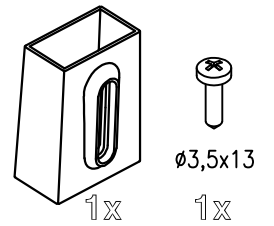

RBGOTRAV1017

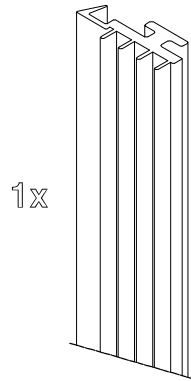

RBAL1347CR

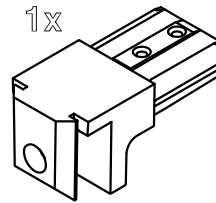

RBPL1348CR

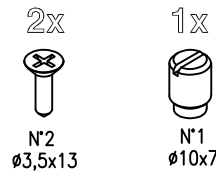
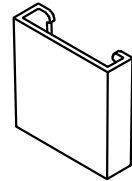

RBCF1260

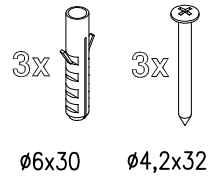

RBGV123600

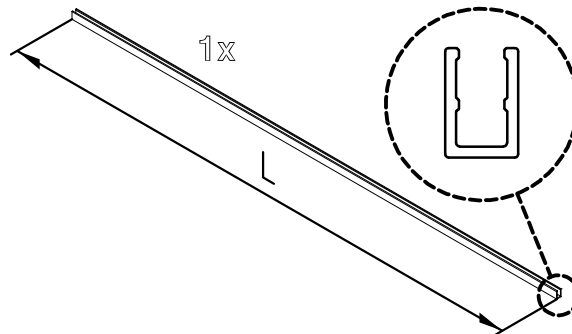
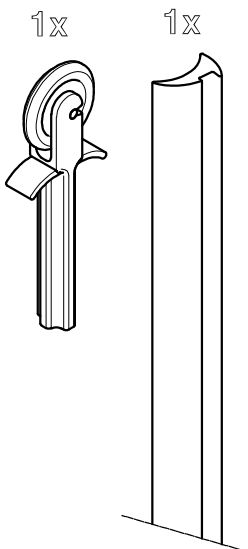

B2560B	RBALR1361AN	L= 165 mm
B2562B	RBALR1362AN	L= 265 mm
B2562A	RBALR1356AN	L= 727 mm
B2564A	RBALR1357AN	L= 827 mm
B2565A	RBALR1358AN	L= 927 mm
B2566A	RBALR1359AN	L= 1127 mm
B2568A	RBALR1360AN	L= 1327 mm

RBPL1346CR

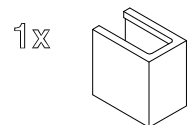

1

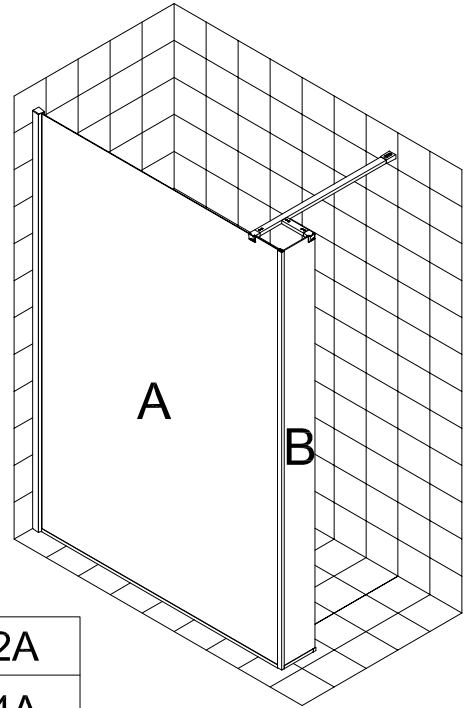
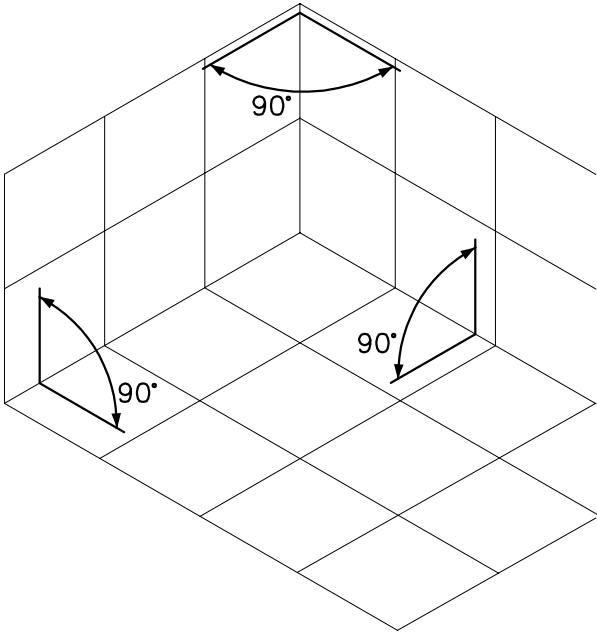

B2562A

B2564A

B2565A

B2566A

B2568A

B2560B

B2561B

2

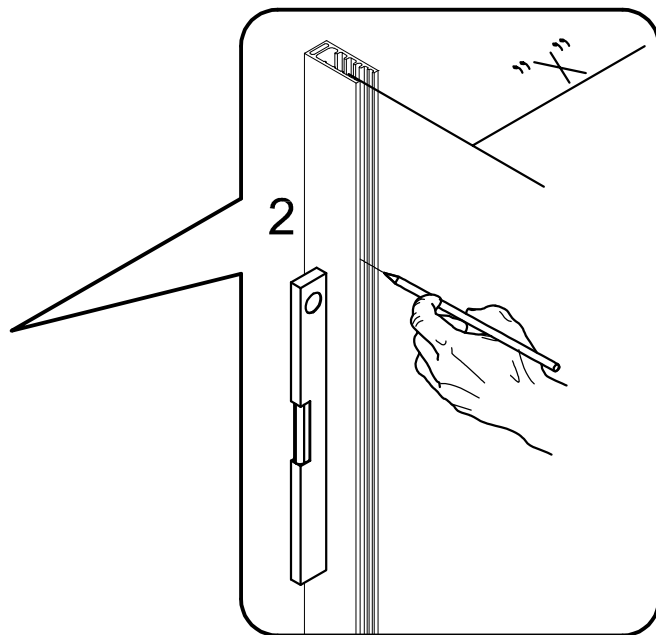
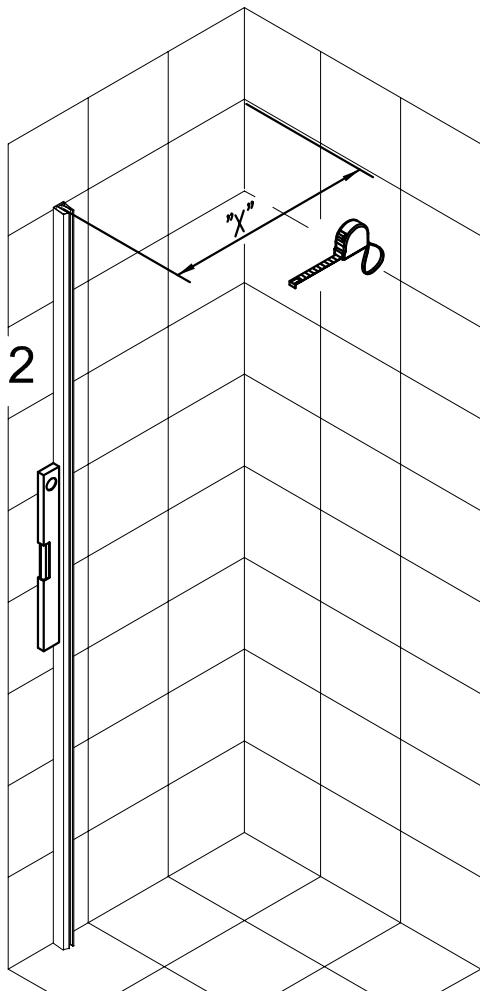

"X" max = 1200 mm

3

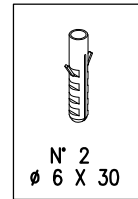
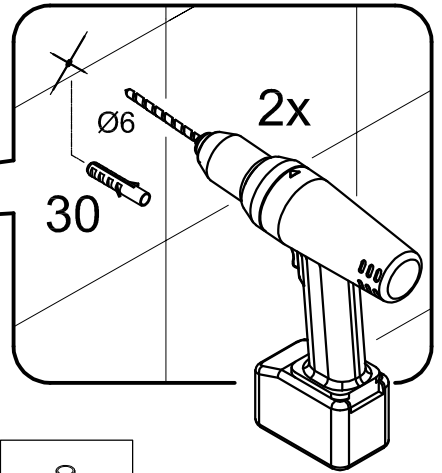
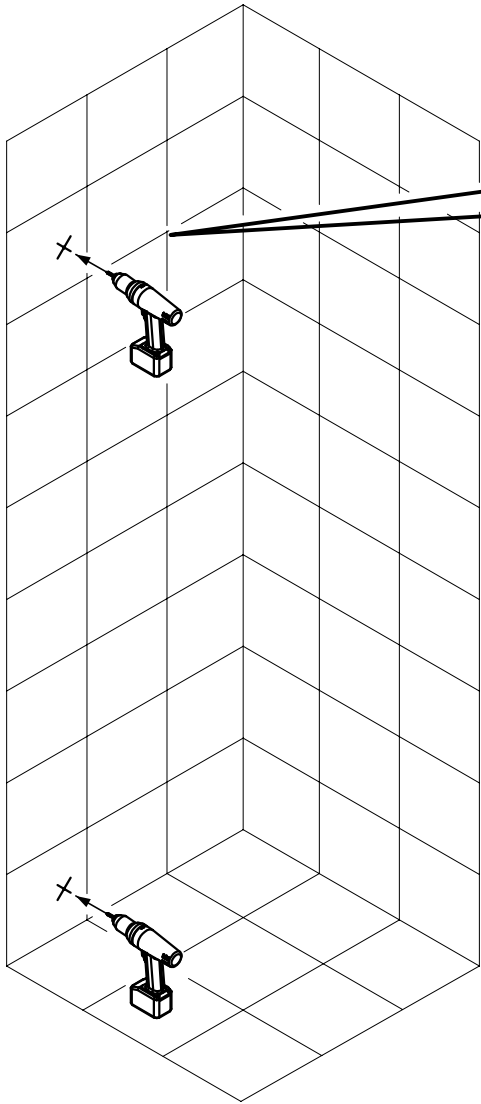

4

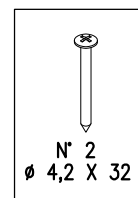
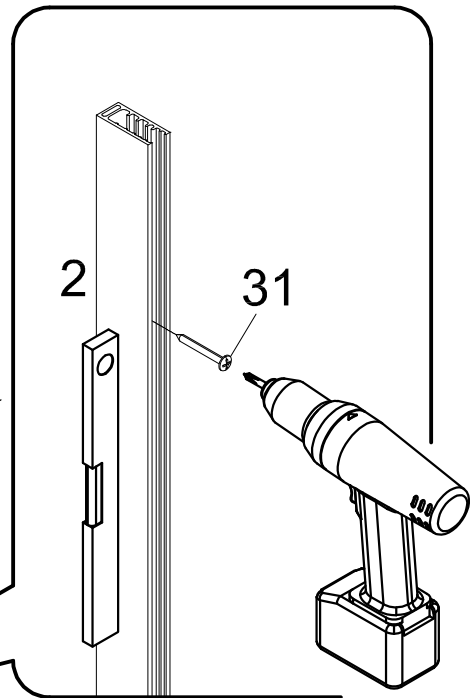
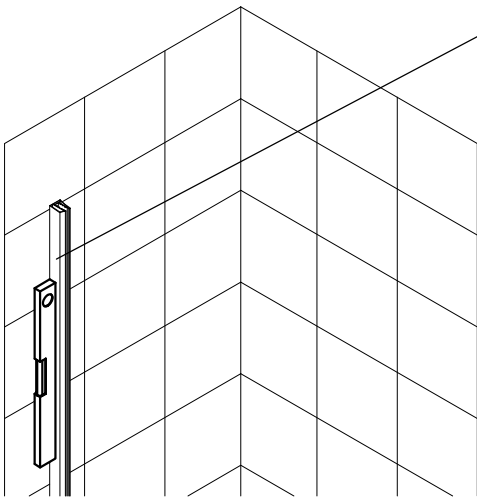

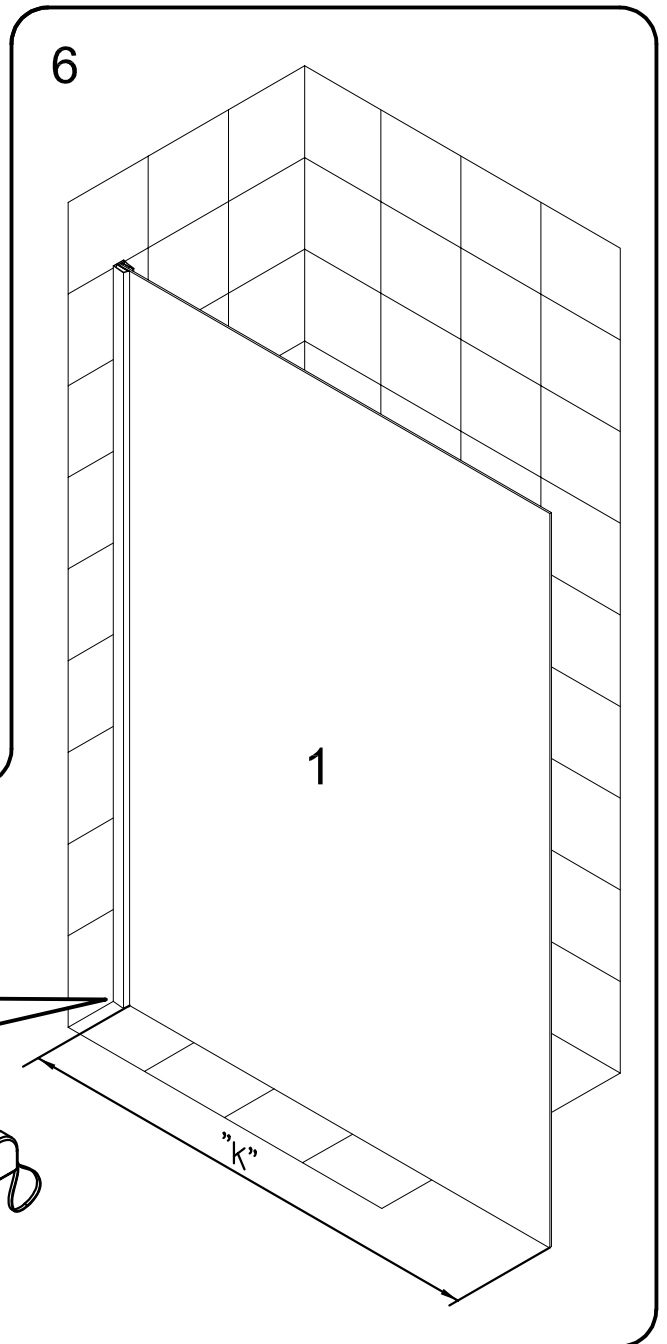
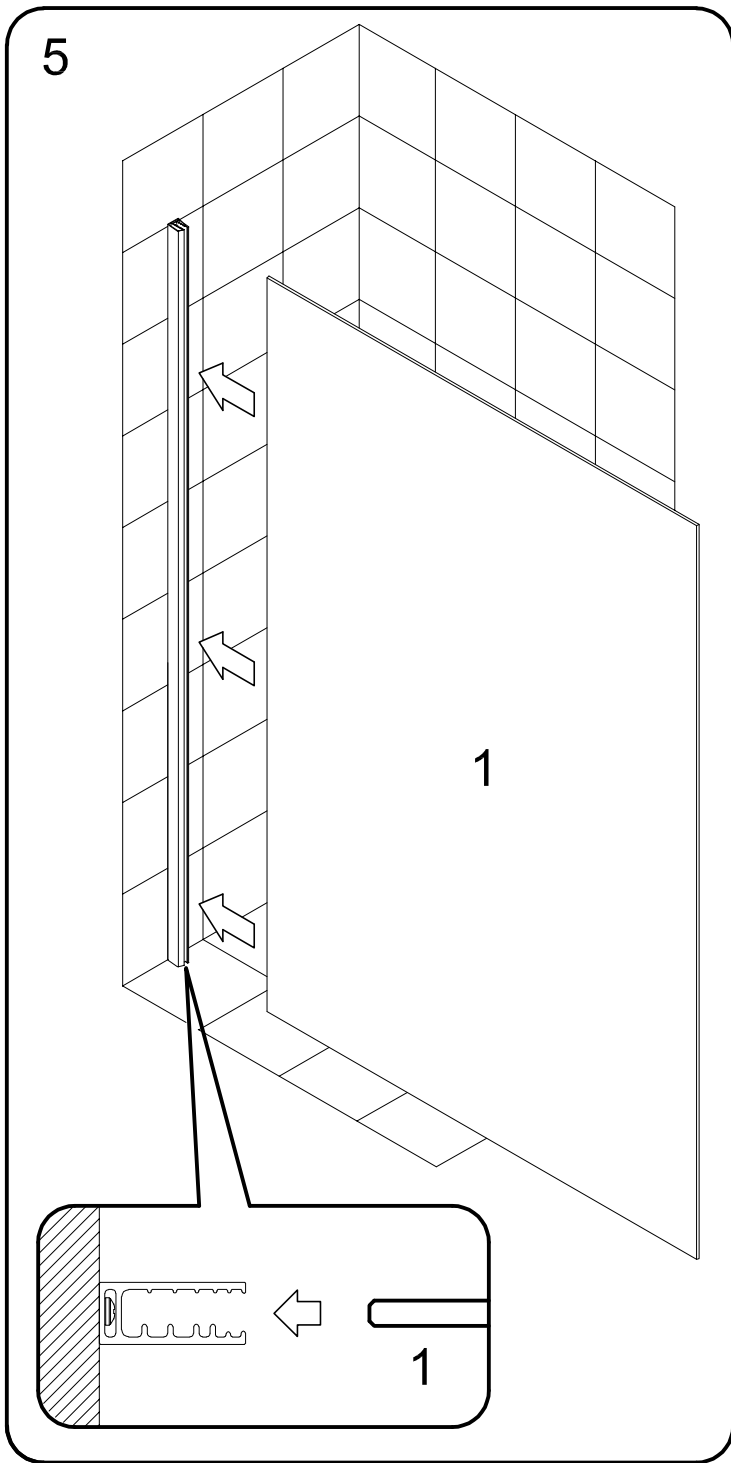

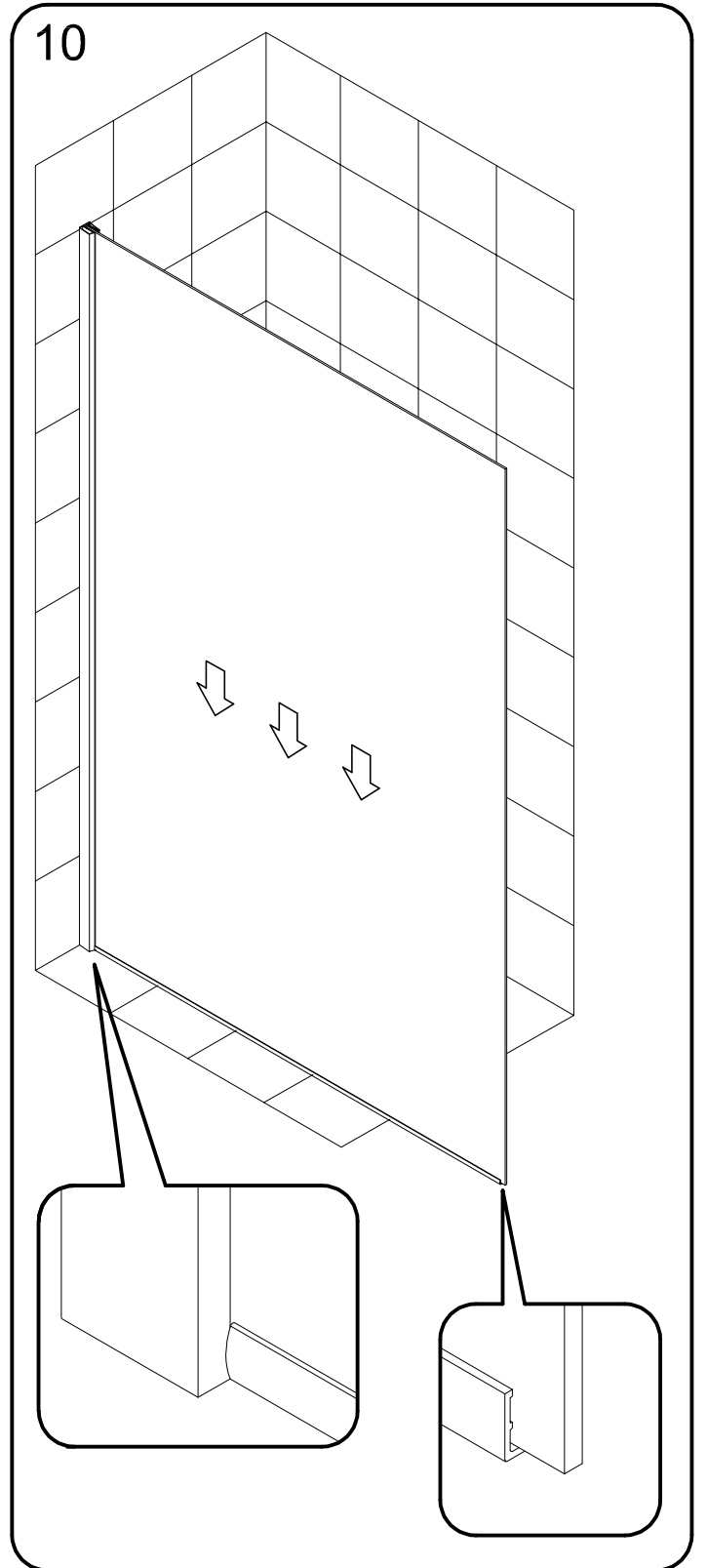
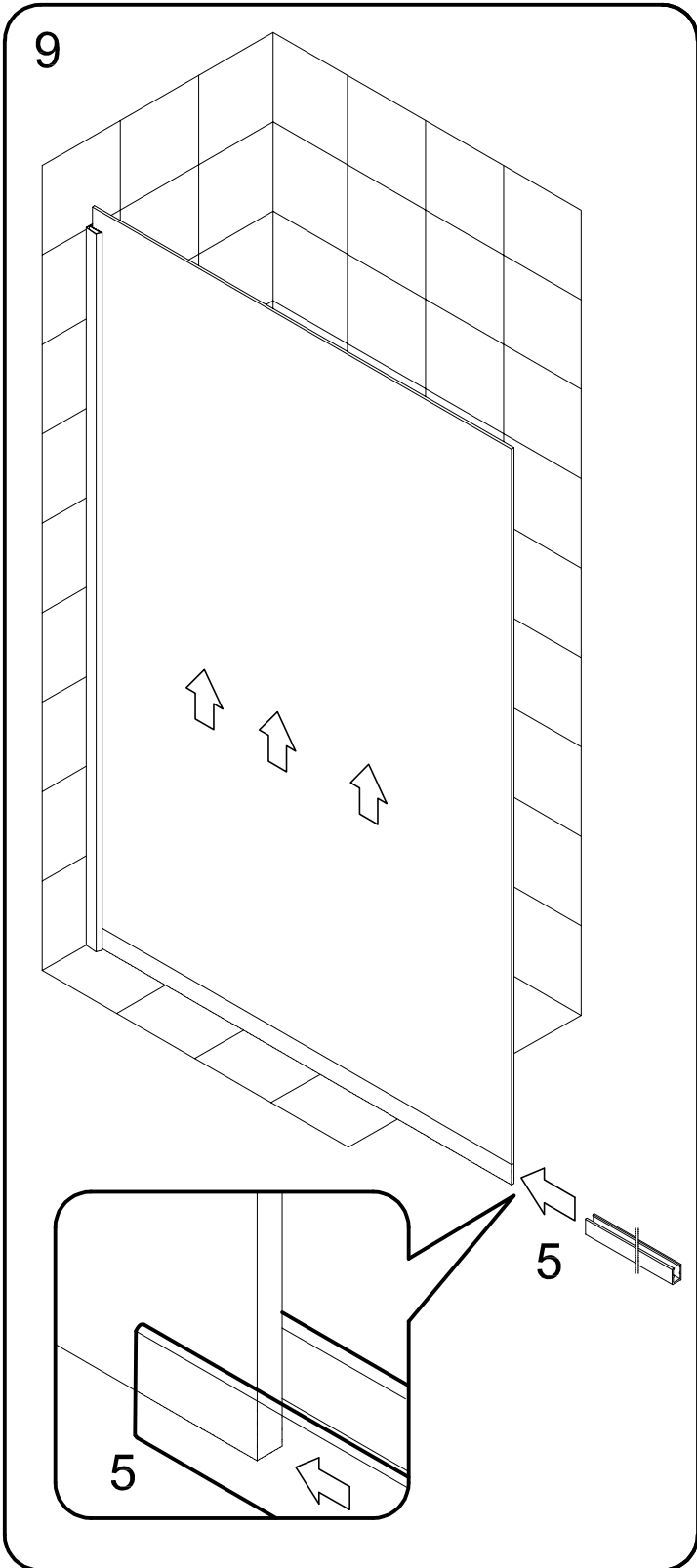
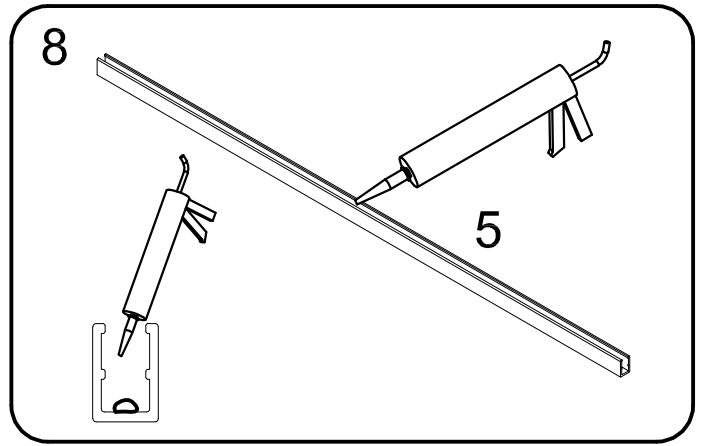
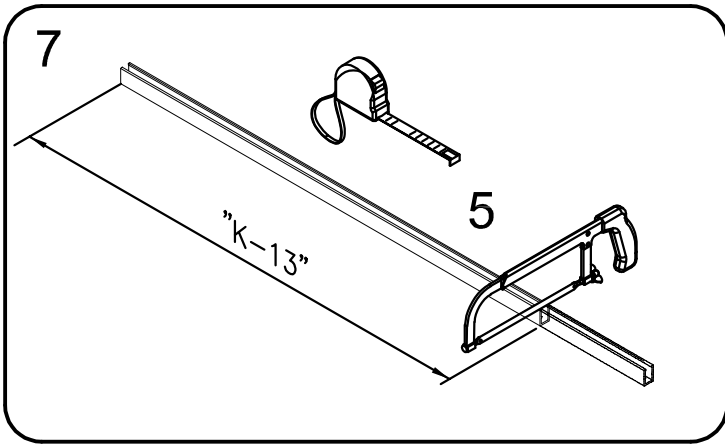

11

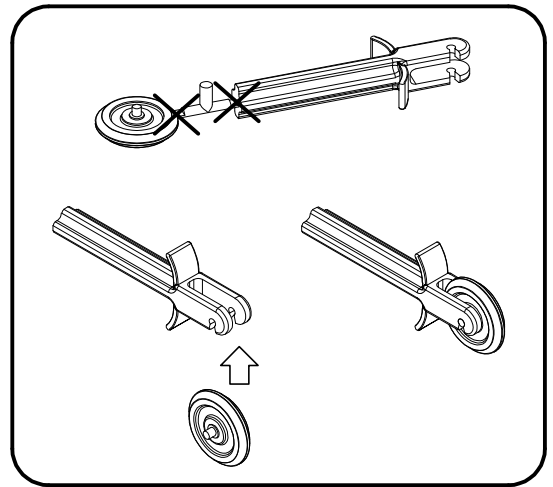
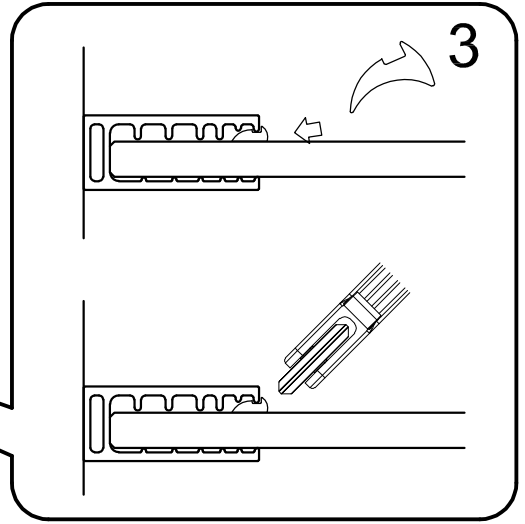
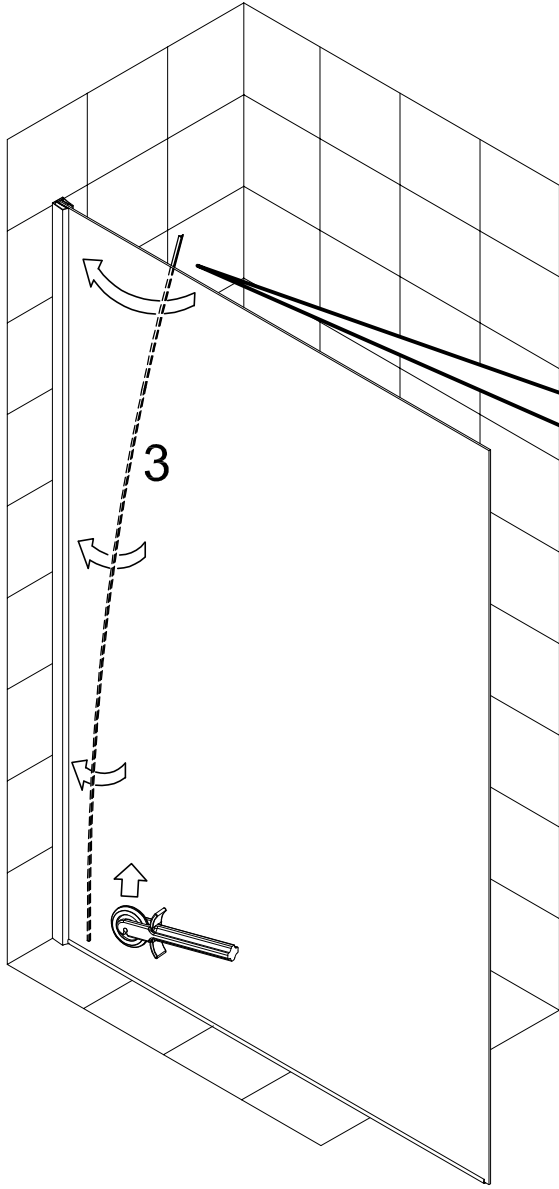

12

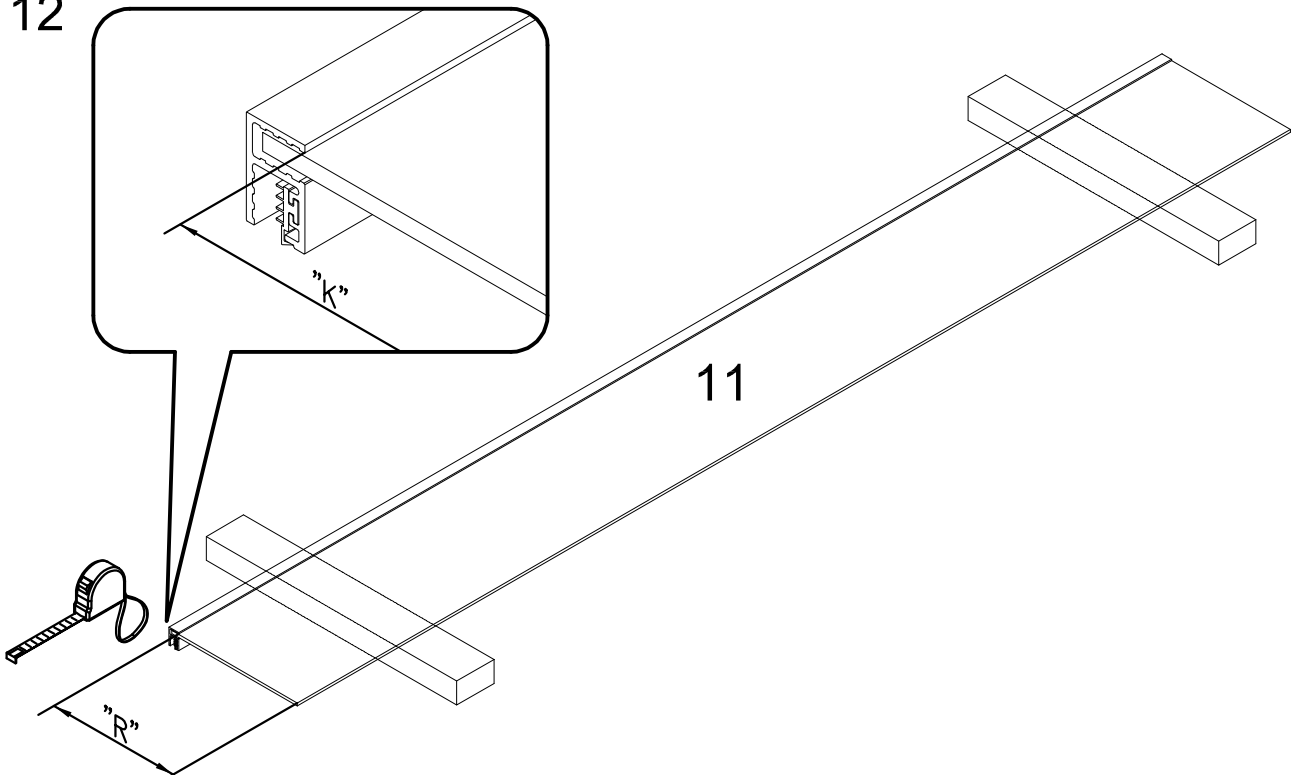

13

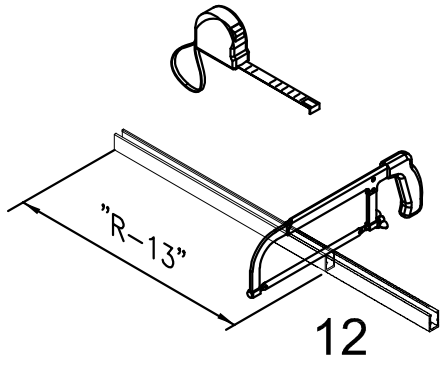

14

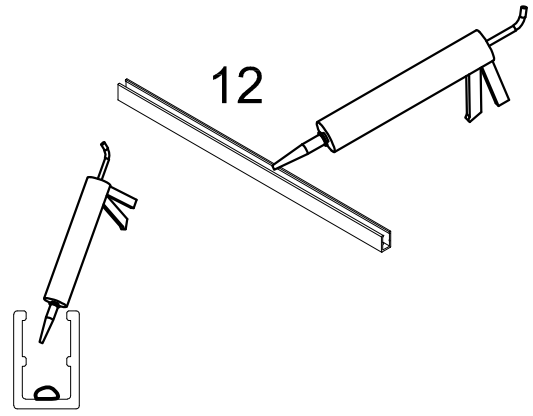

15

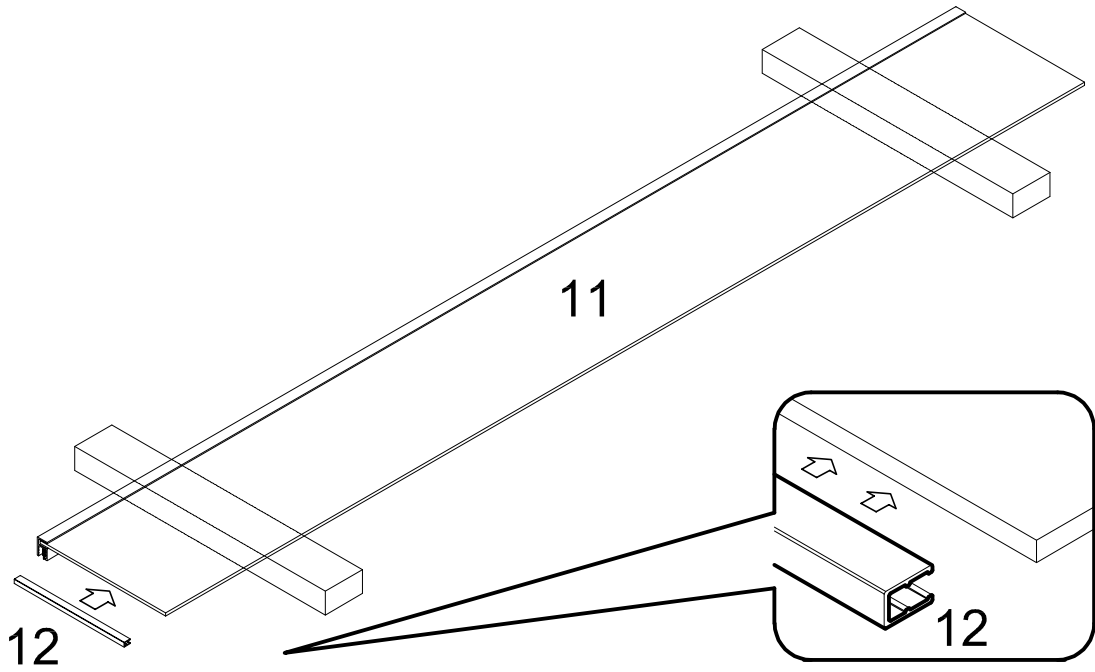

16

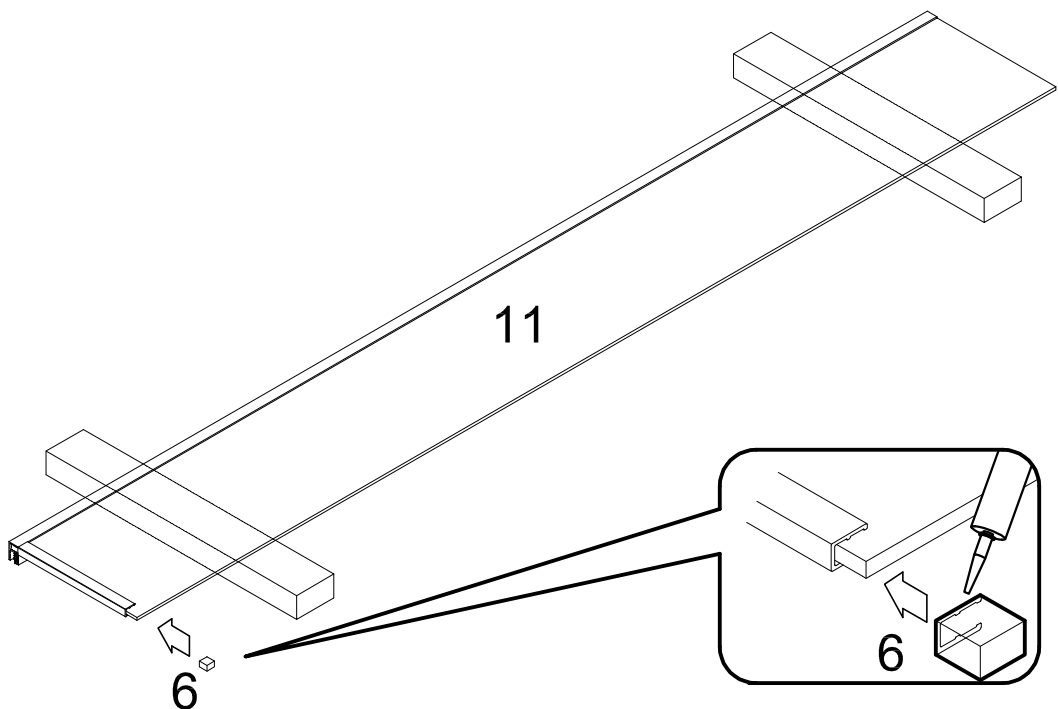

17

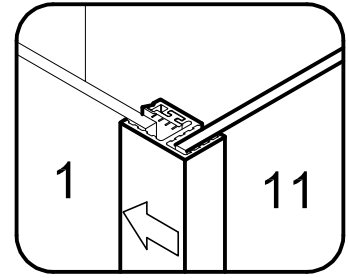
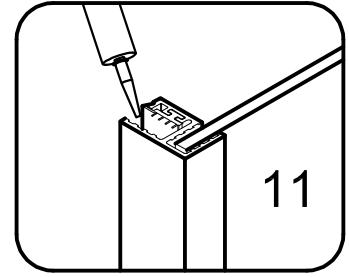
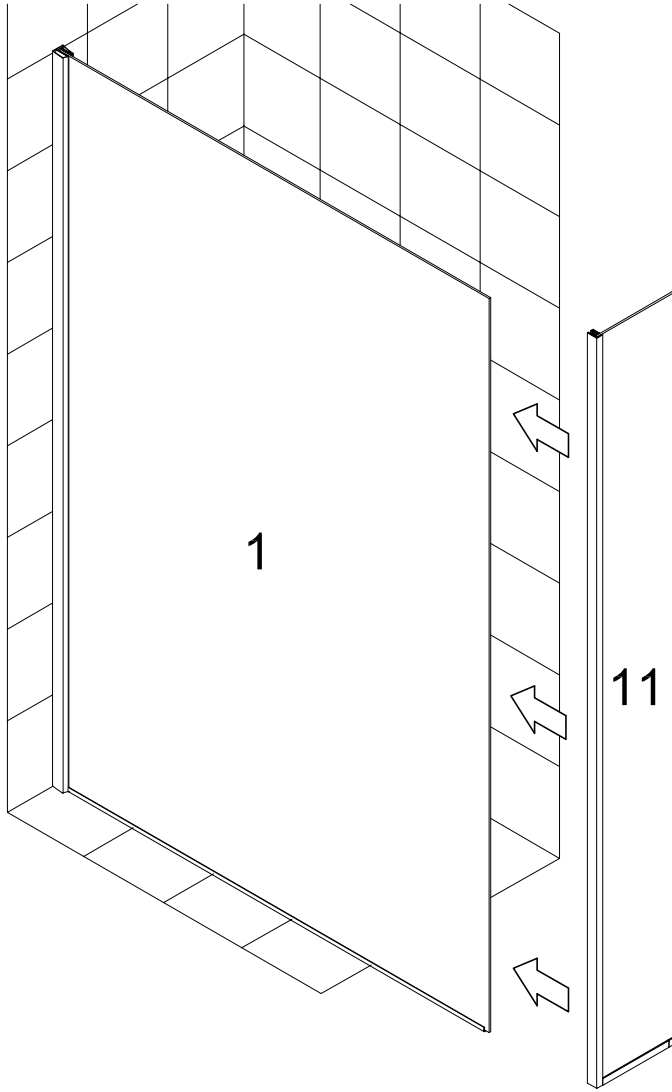

18

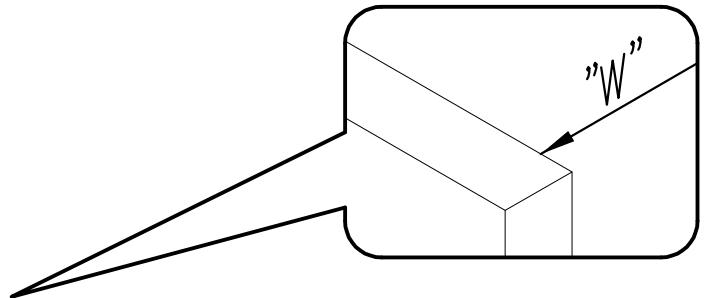
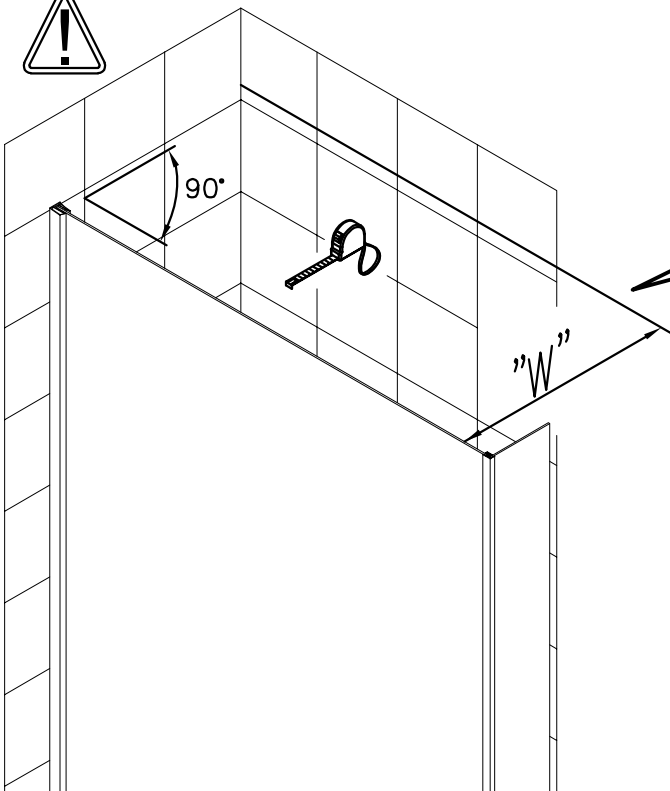

19

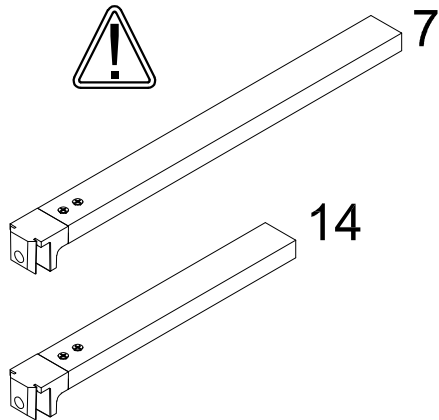

$$"Z" = (W - 17_{\pm 1} \text{ mm})$$

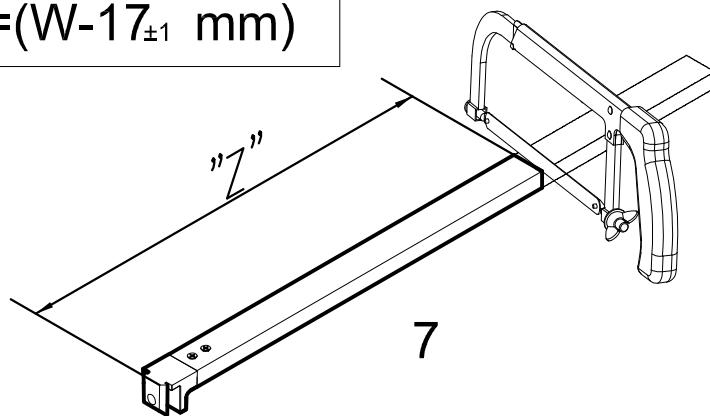

20

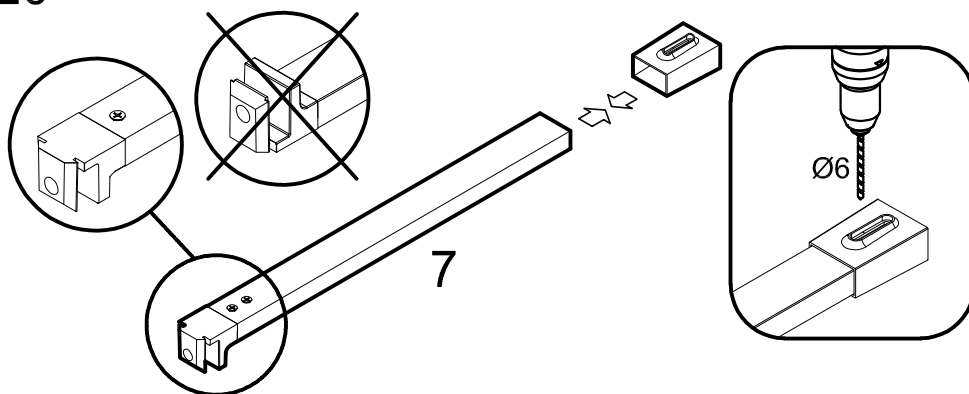

21

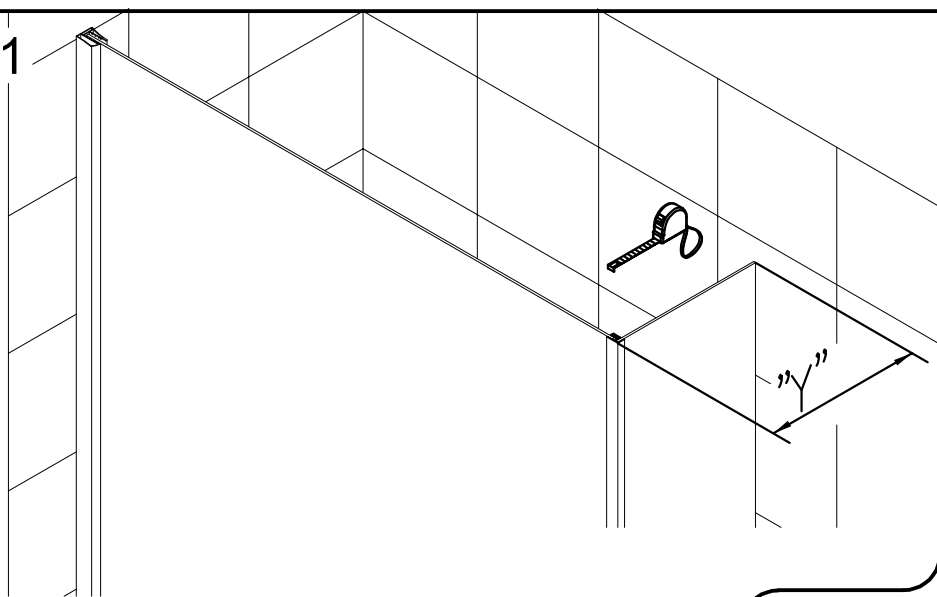

$$"H" = (Y - 45 \text{ mm})$$

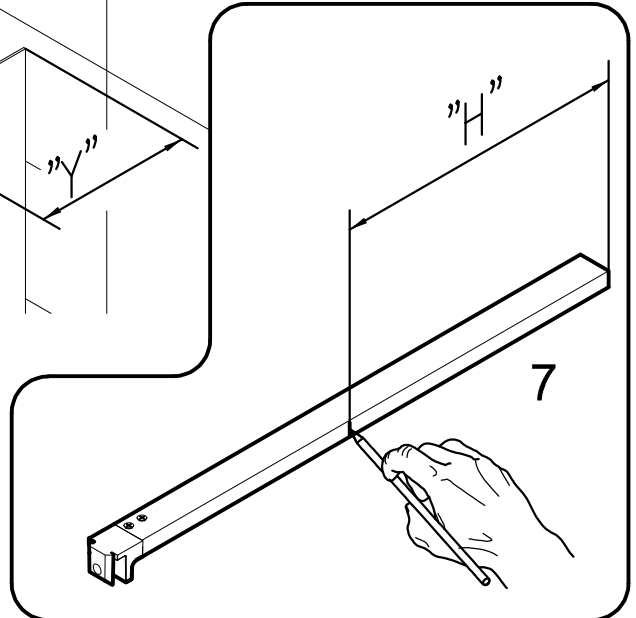

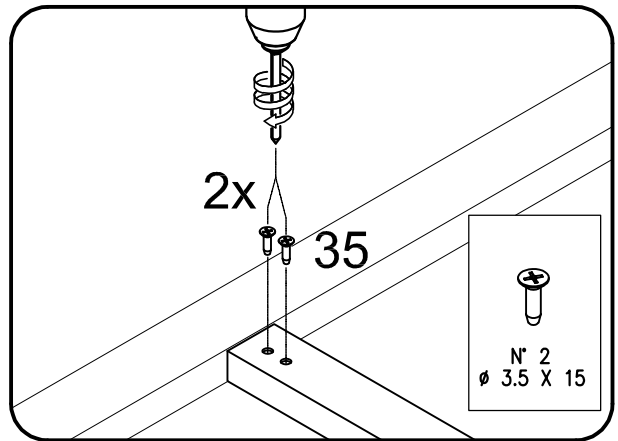
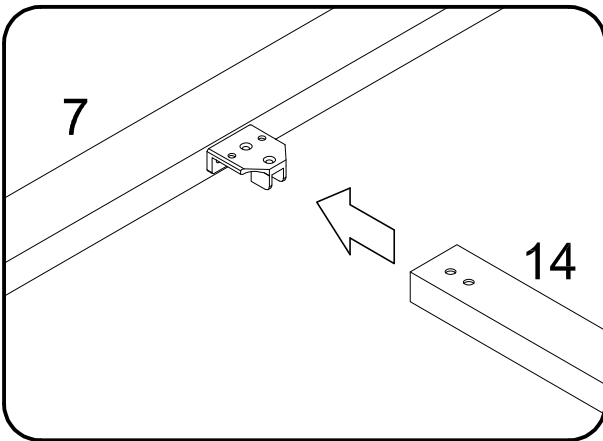
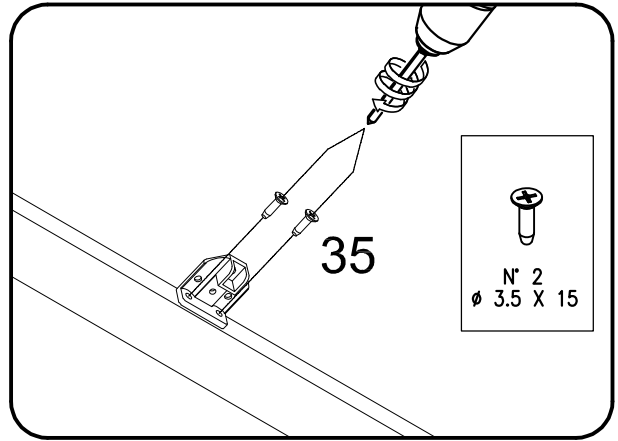
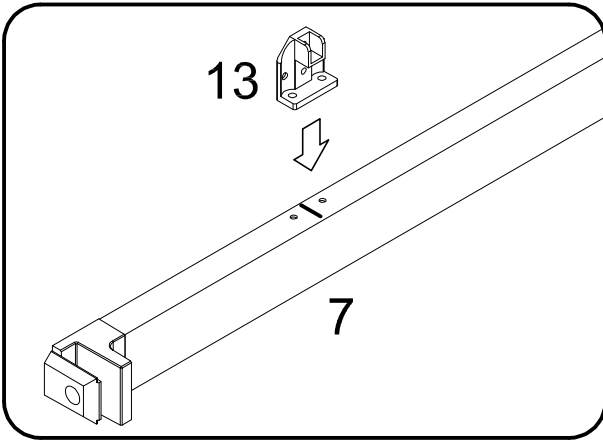
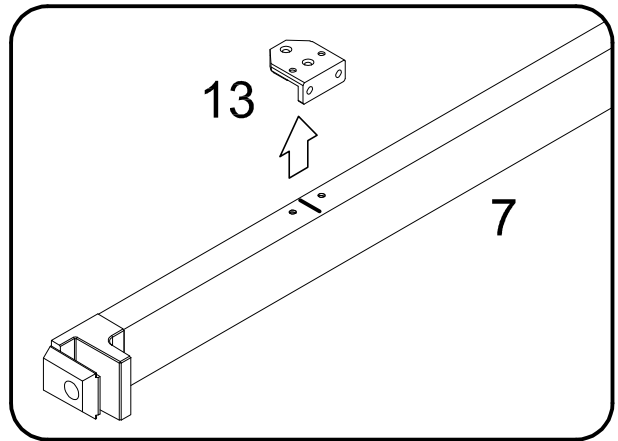
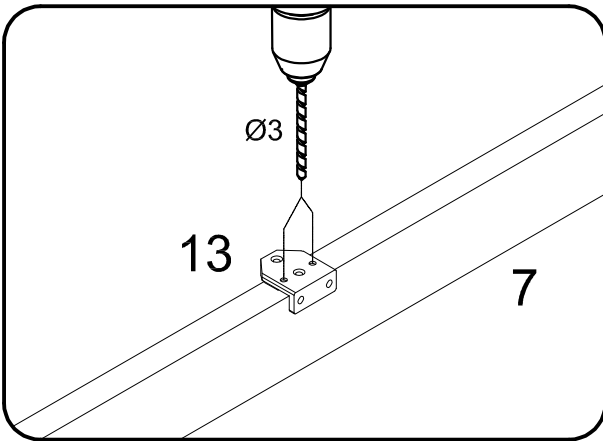
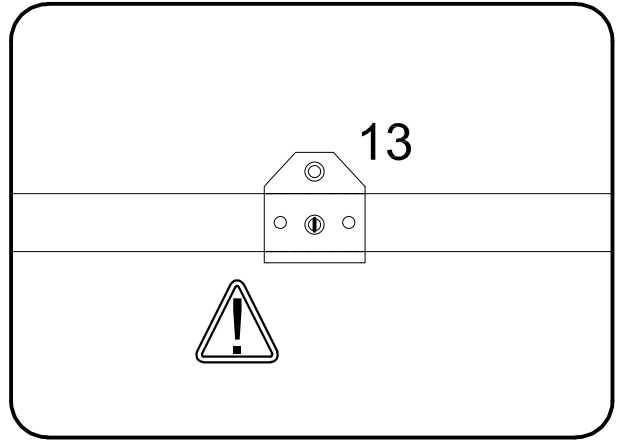
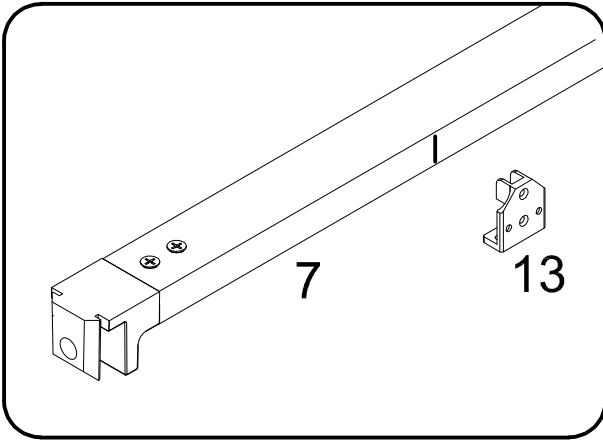

23

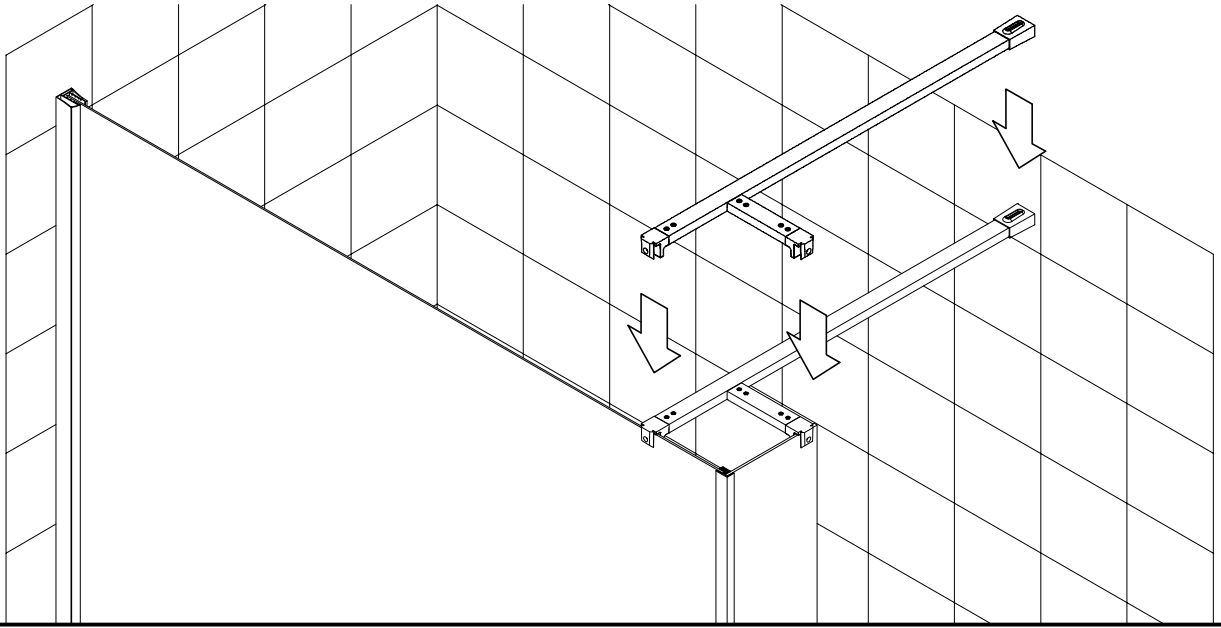

24

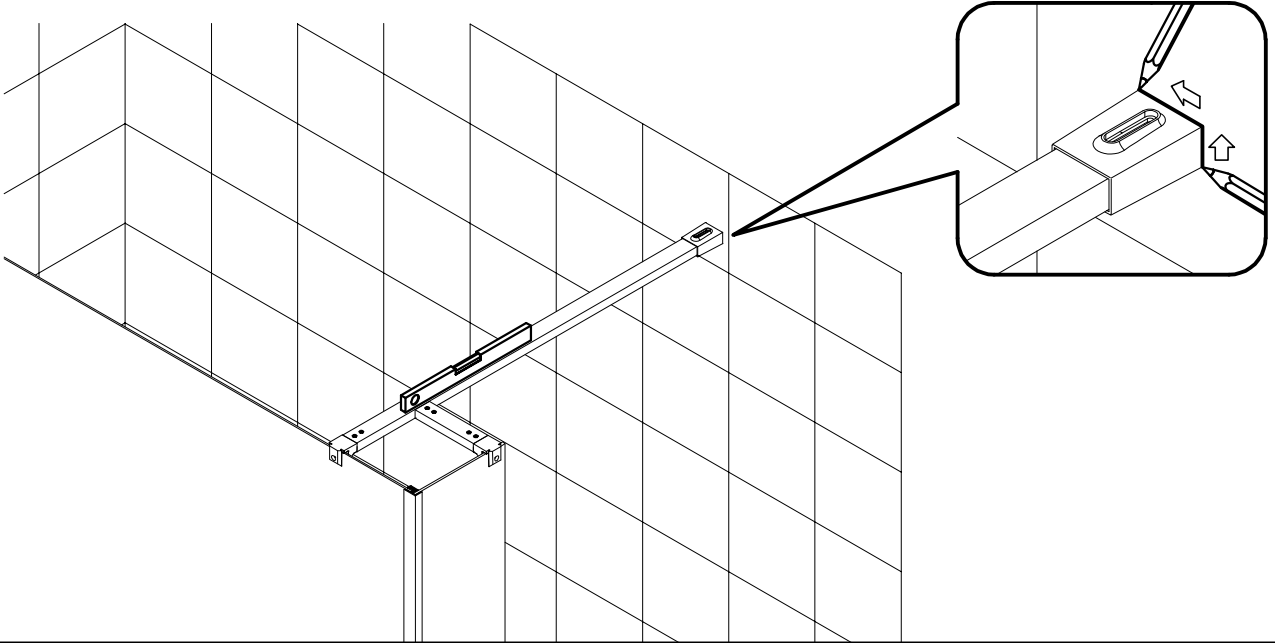

25

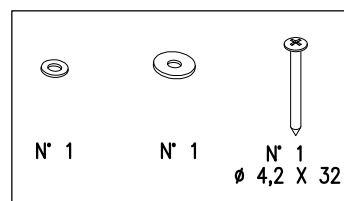
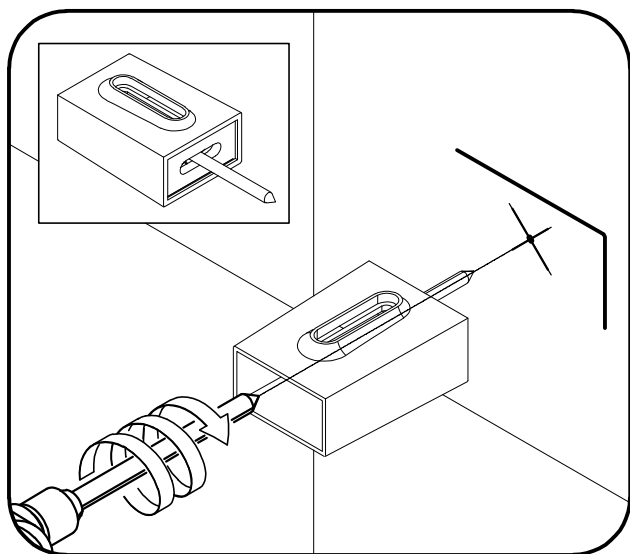
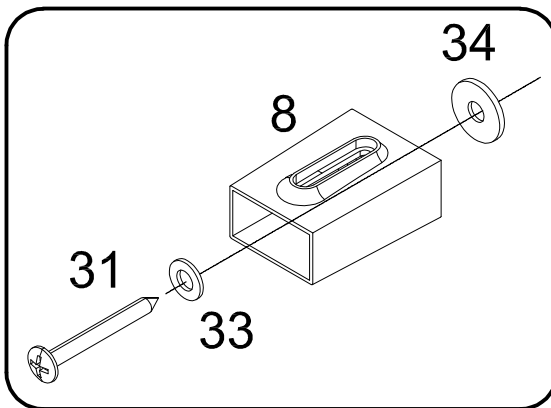
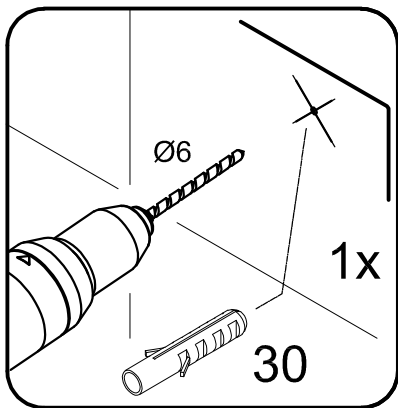
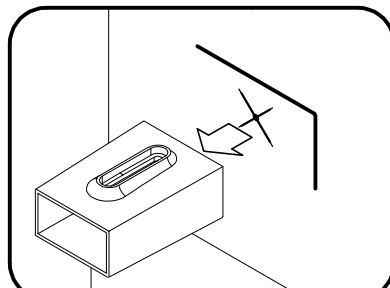
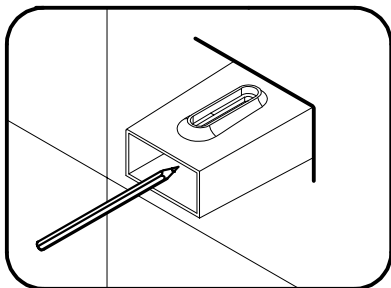
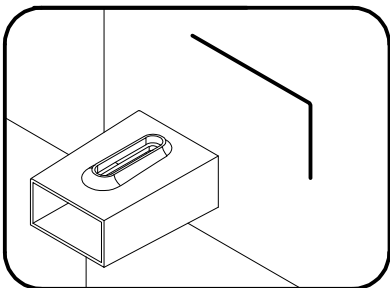
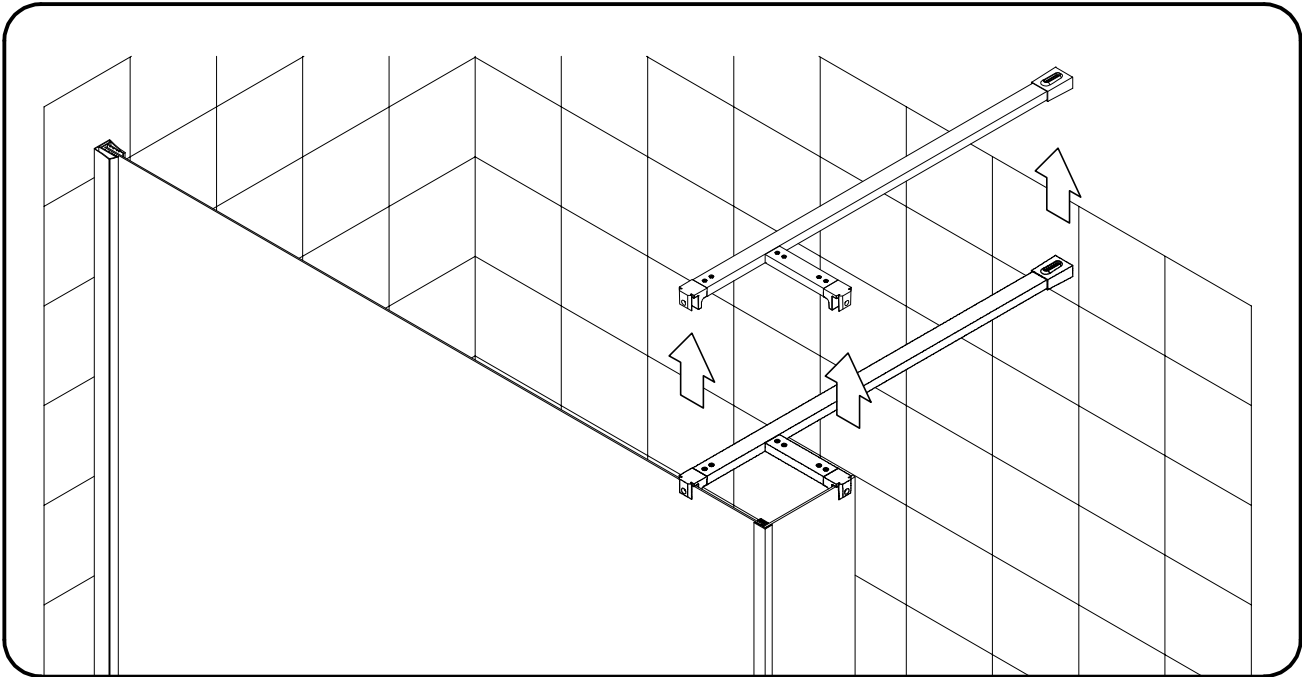

26

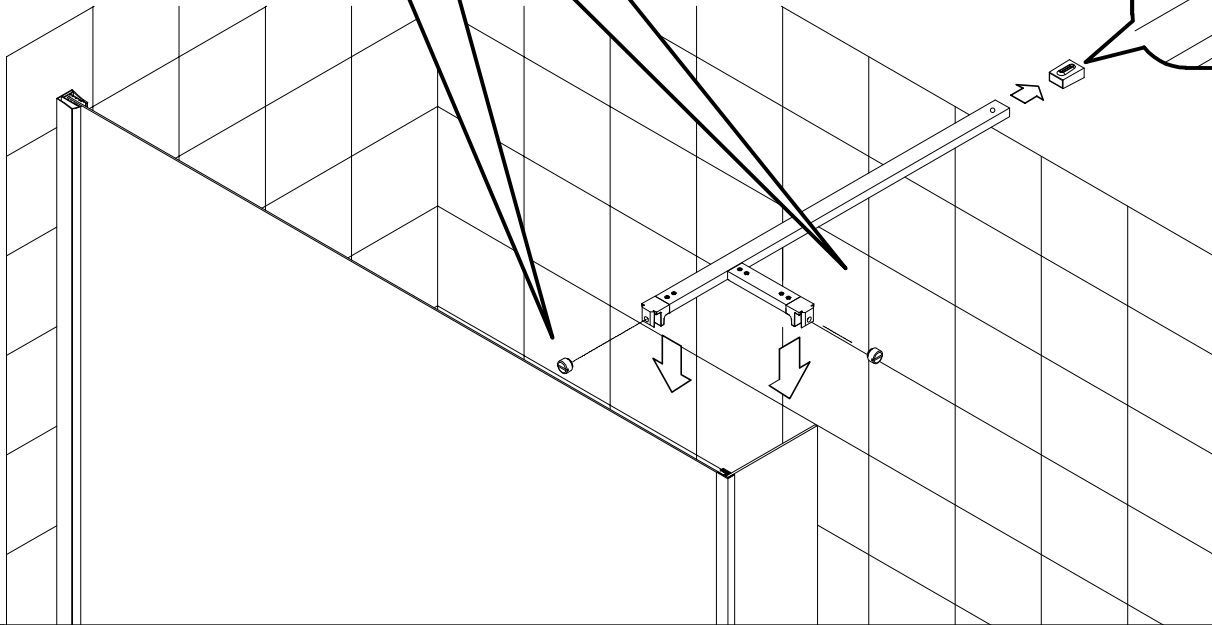
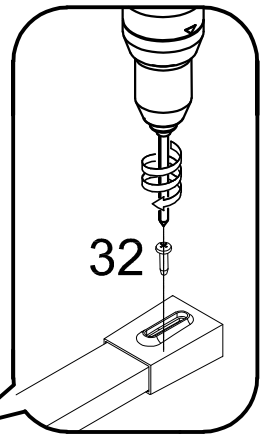
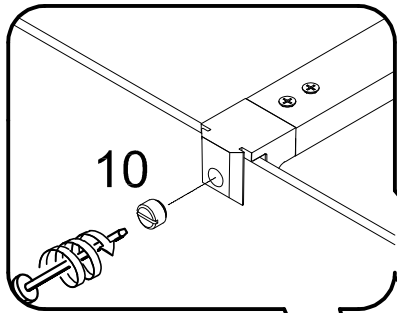

27

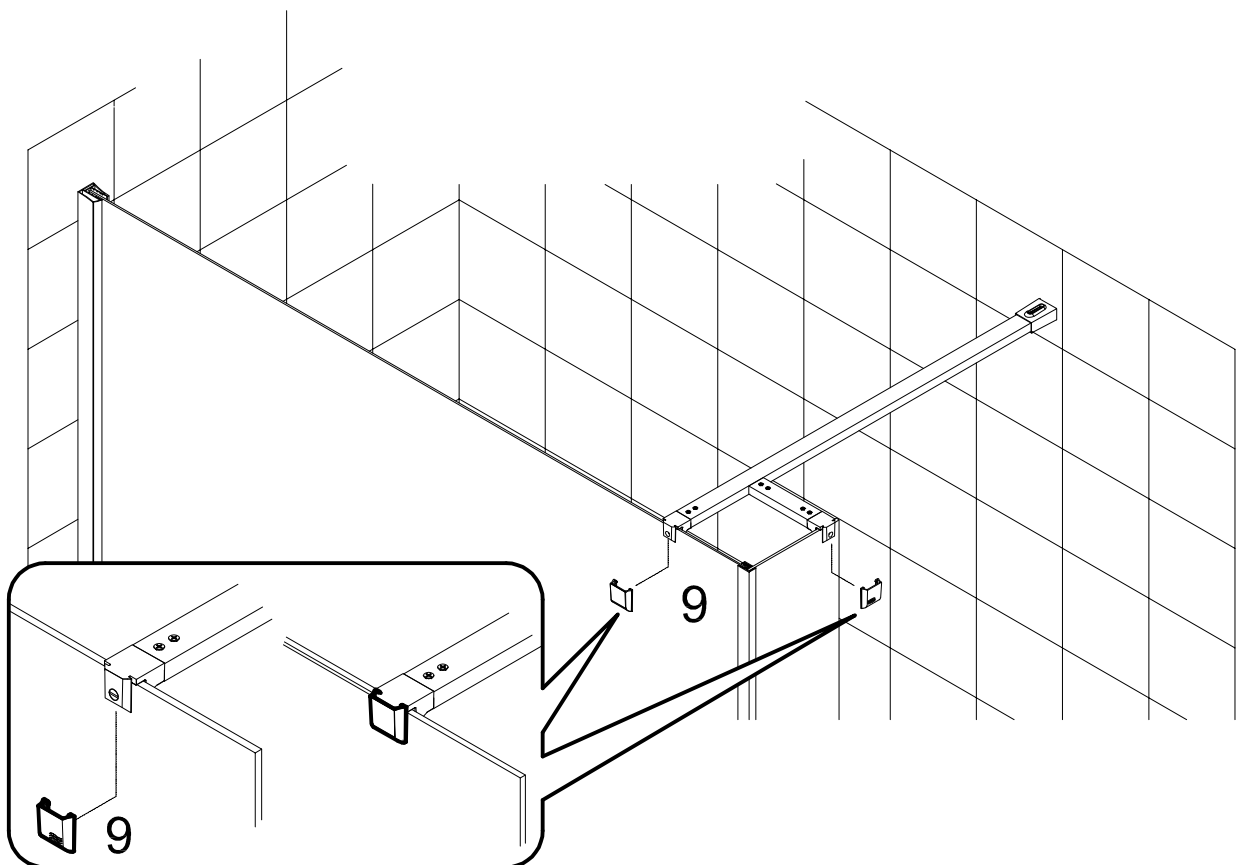



Pag. 1

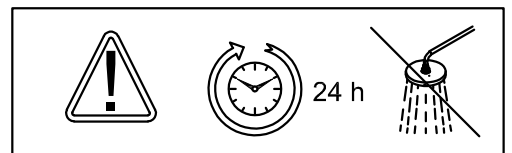
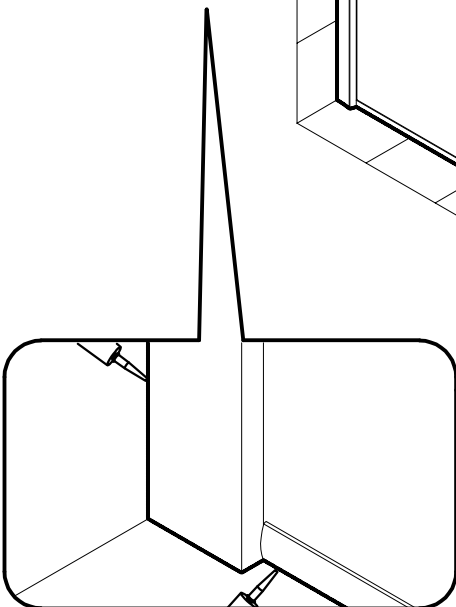
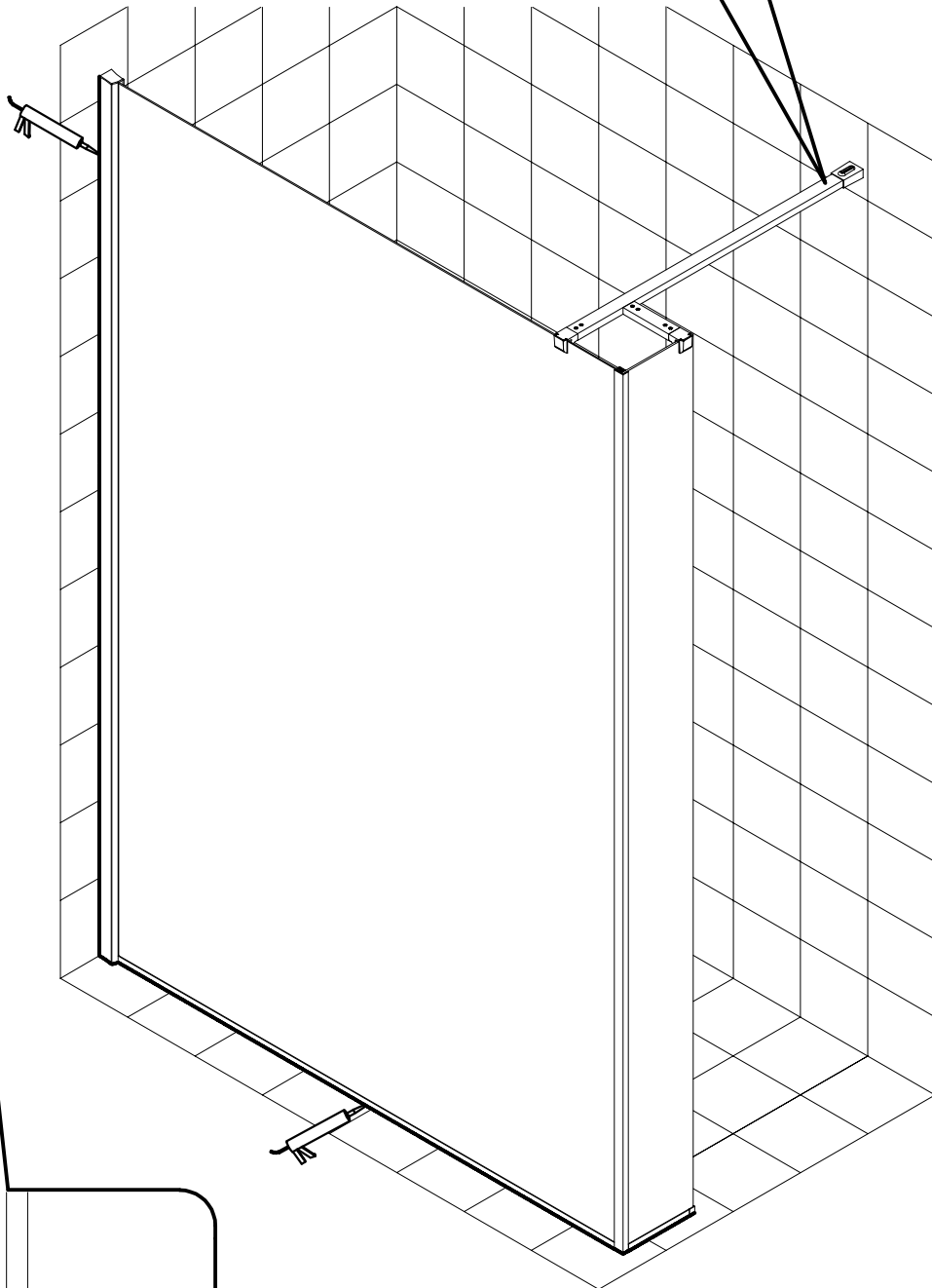
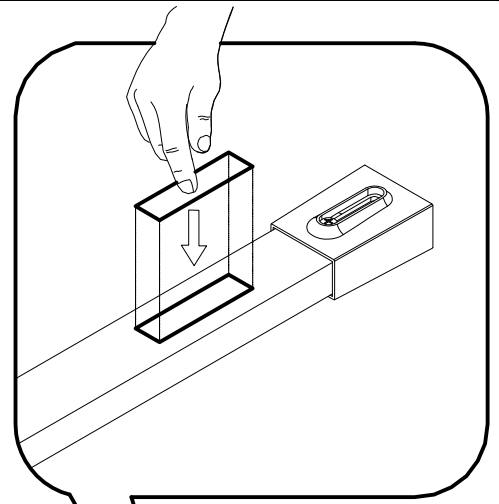
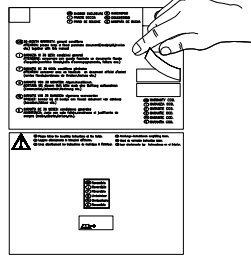

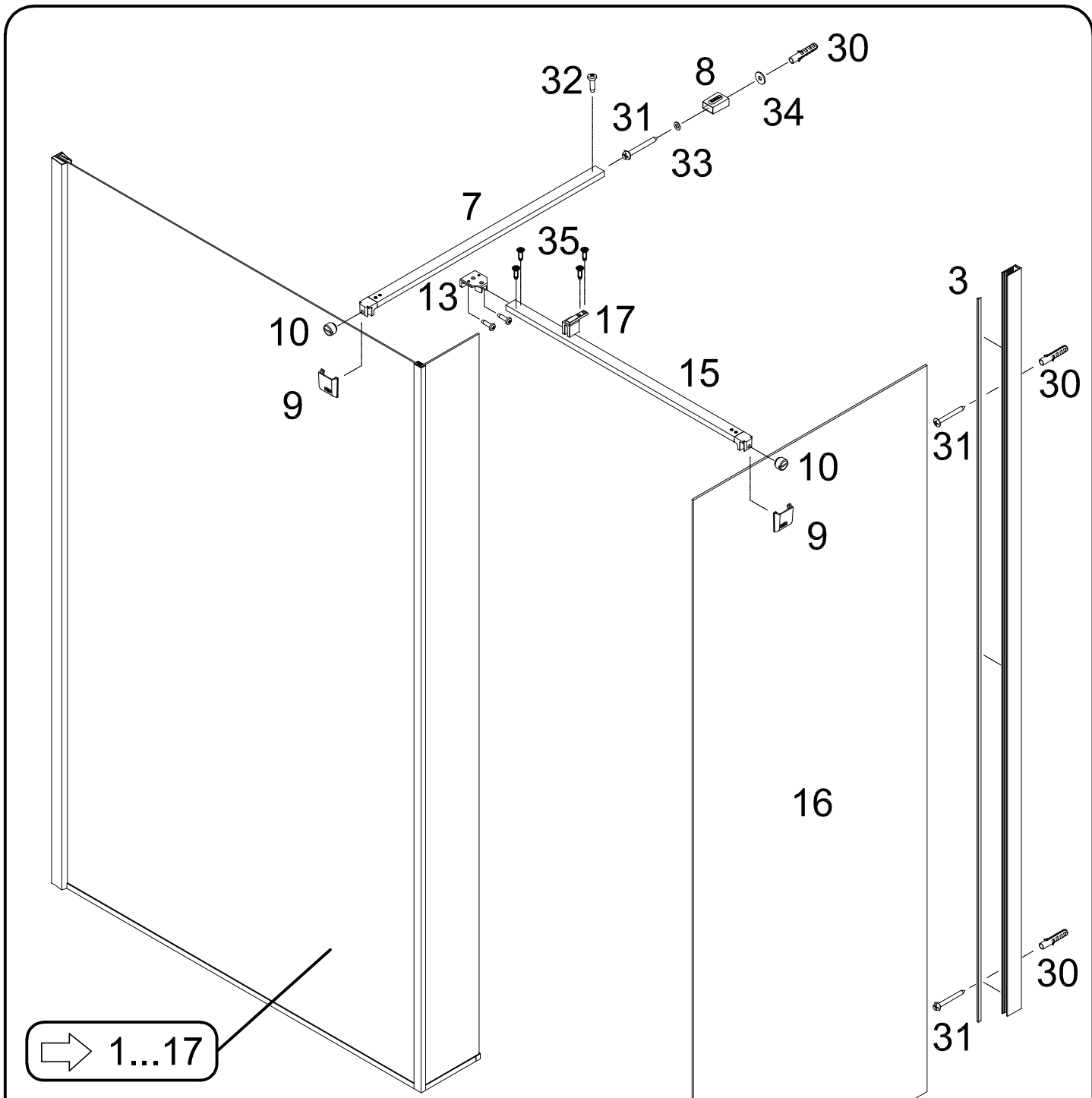

➔ 1...17

30	31	32	33	34	35
N° 3 Ø 6 X 30	N° 3 Ø 4,2 X 32	N° 1 Ø 3,5 X 13	N° 1	N° 1	N° 4 Ø 3,5 X 13

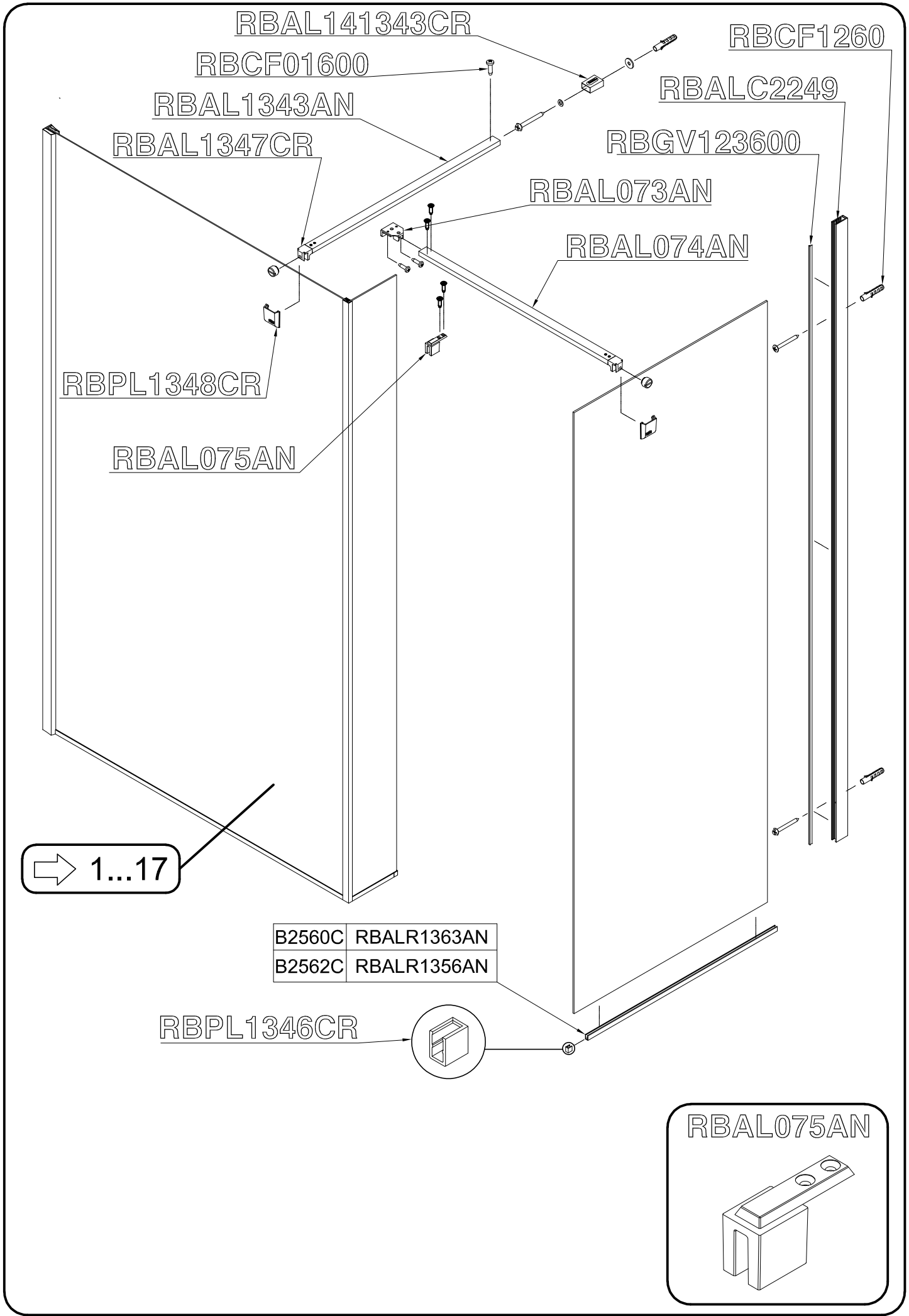

➔ 1...17

B2560C	RBALR1363AN
B2562C	RBALR1356AN

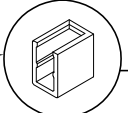

29

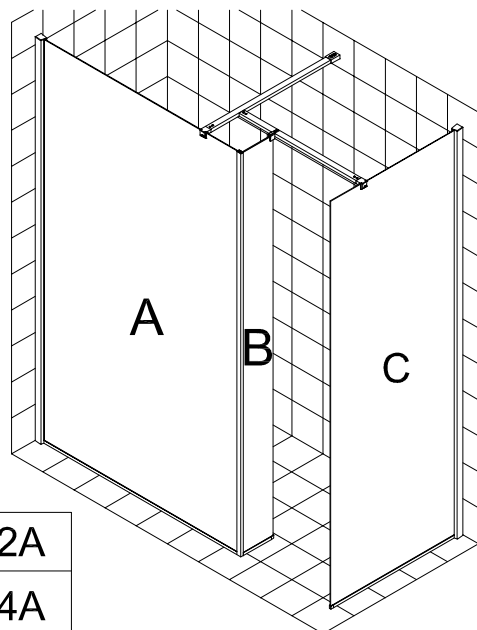
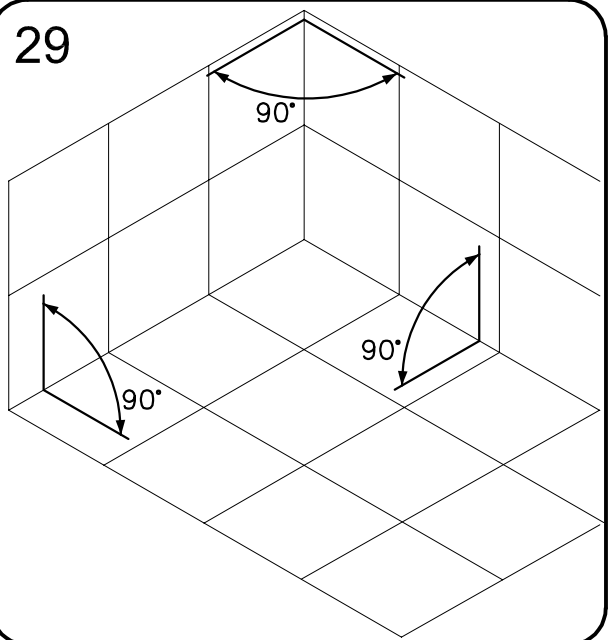

B2562A

B2564A

B2565A

B2566A

B2568A

B2560B

B2561B

B2560C

B2562C

30

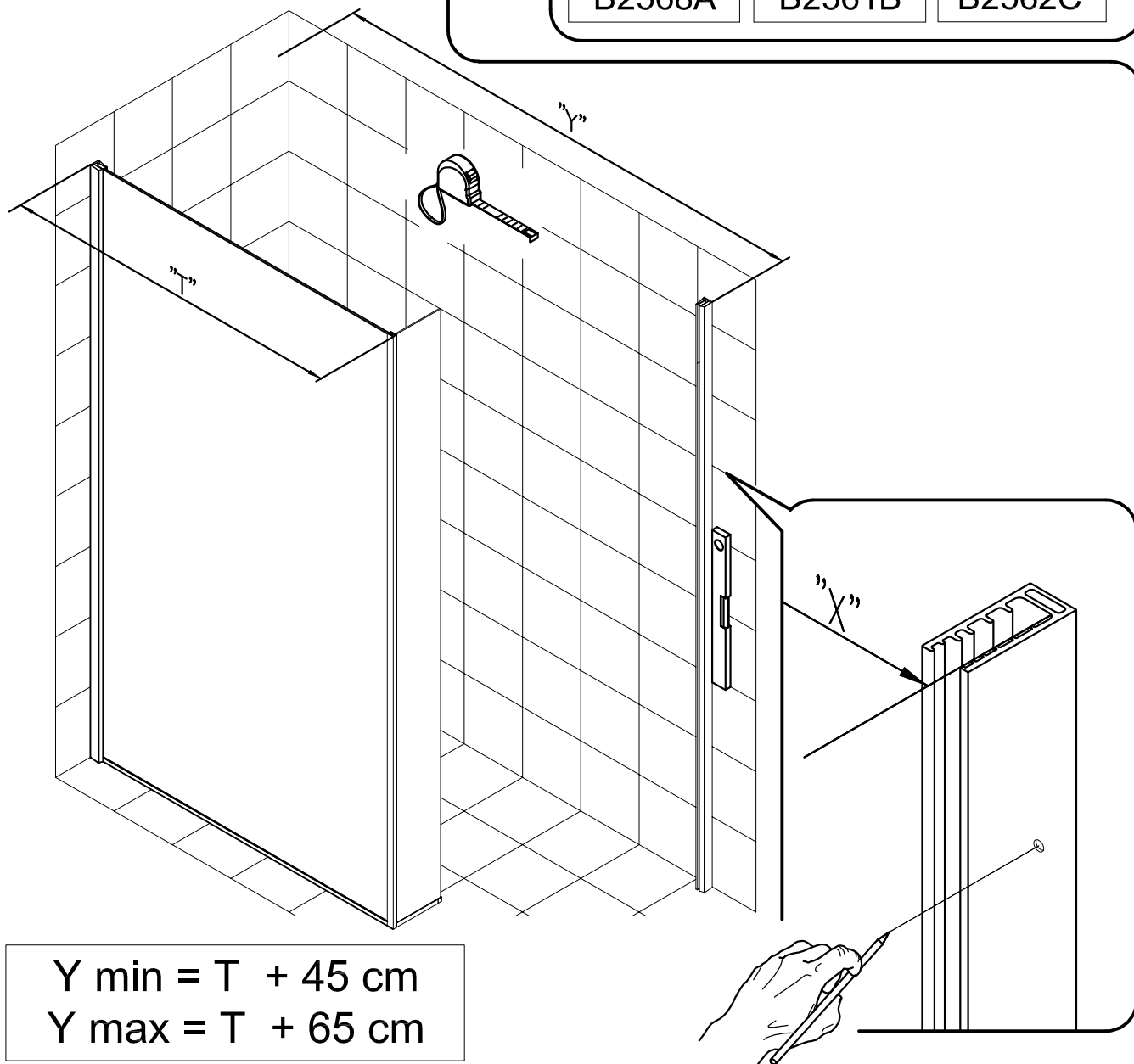

$$Y \text{ min} = T + 45 \text{ cm}$$

$$Y \text{ max} = T + 65 \text{ cm}$$

31

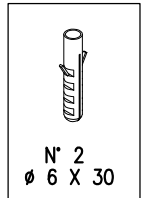
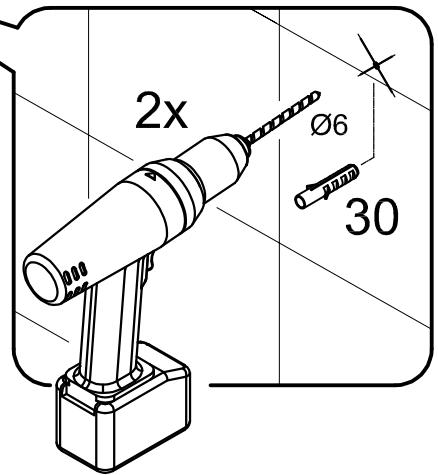
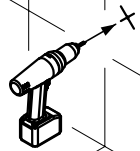
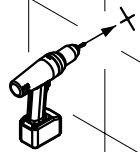
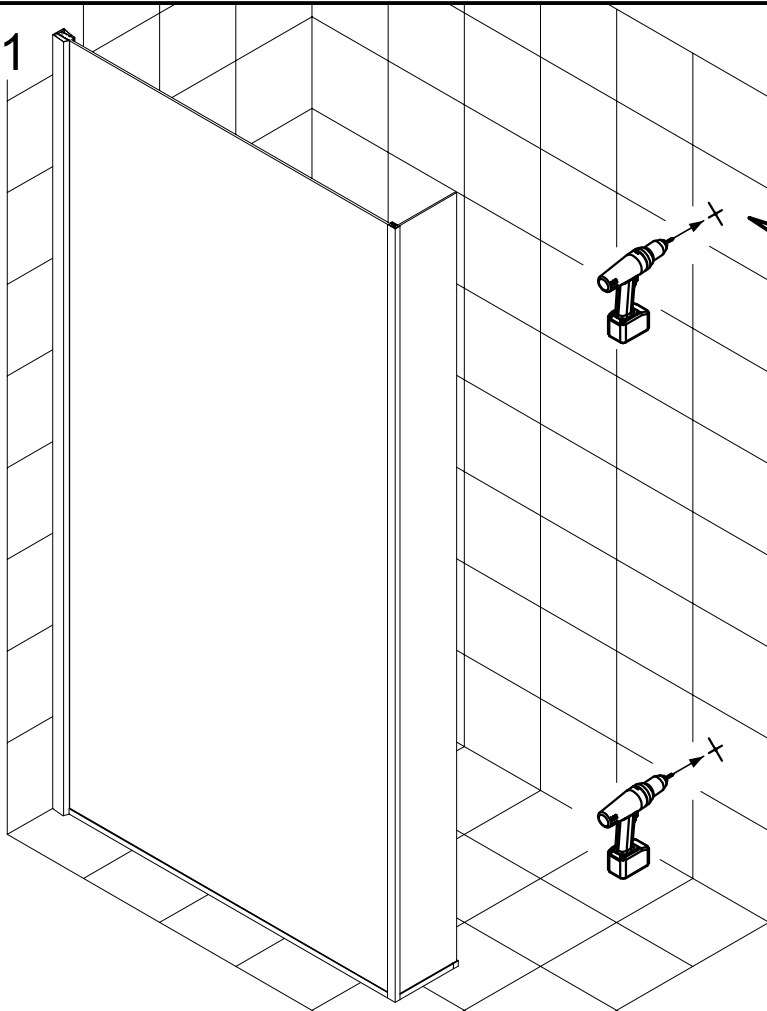

32

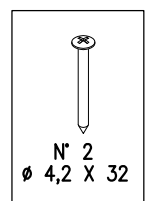
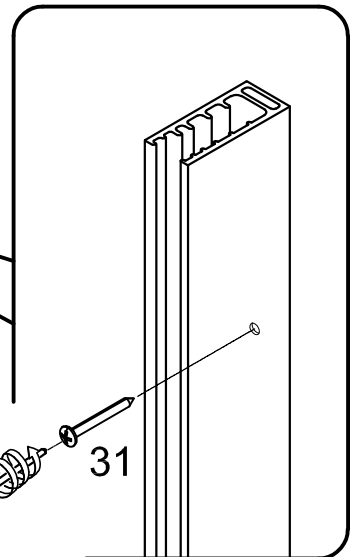
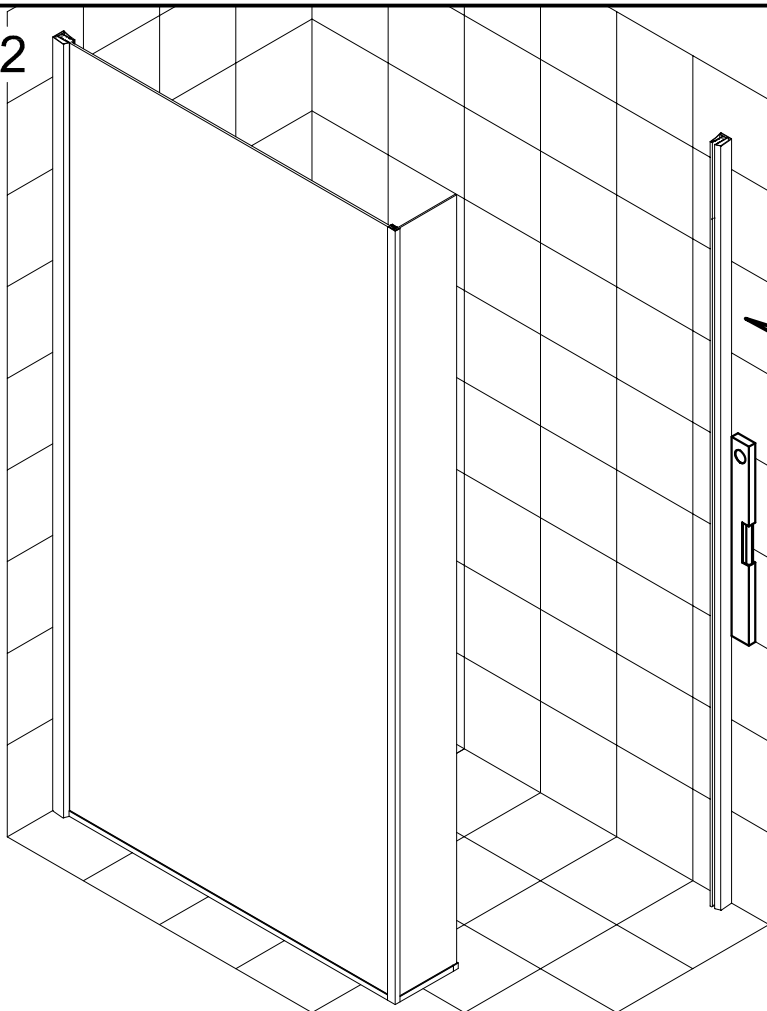

33

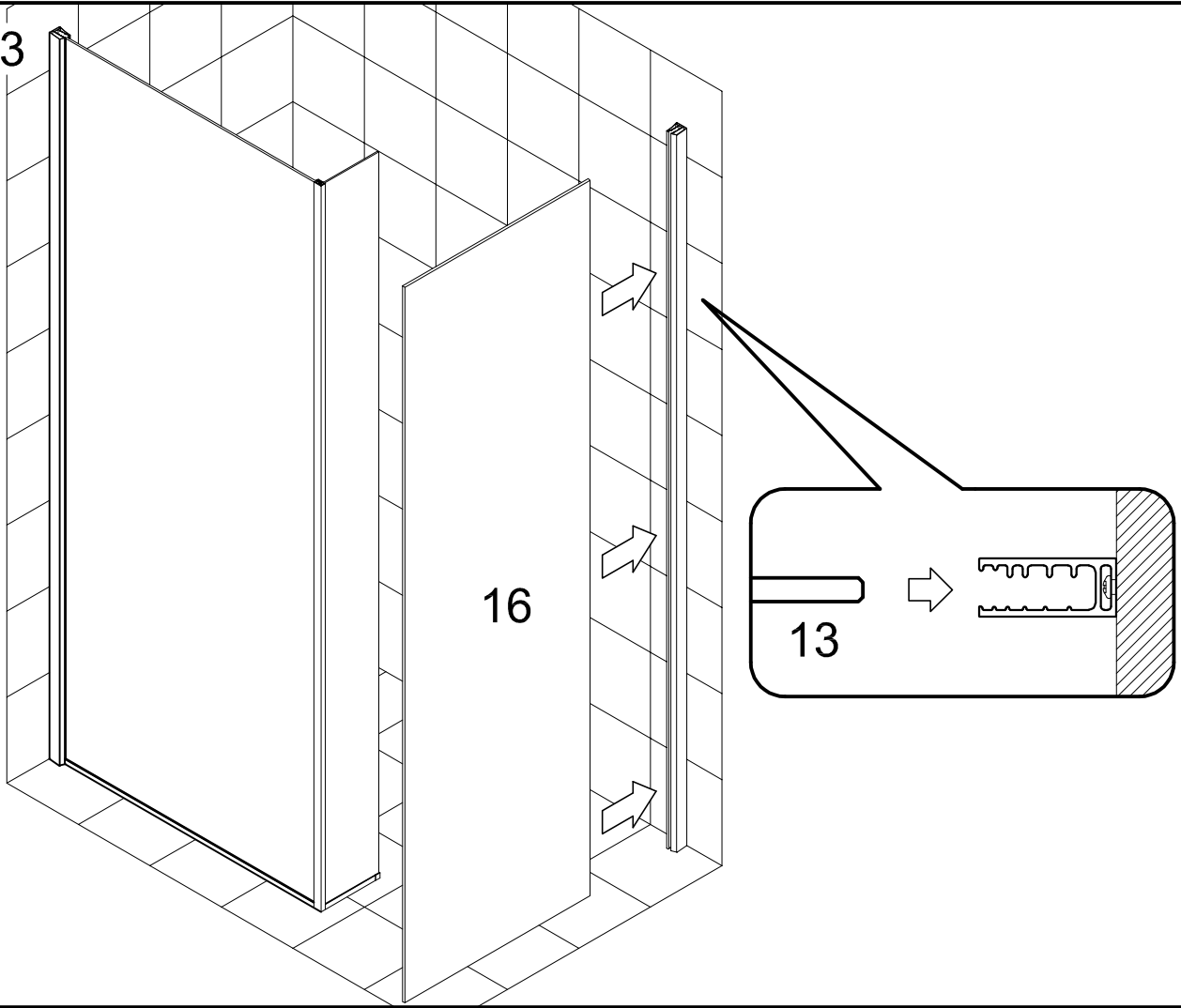

34

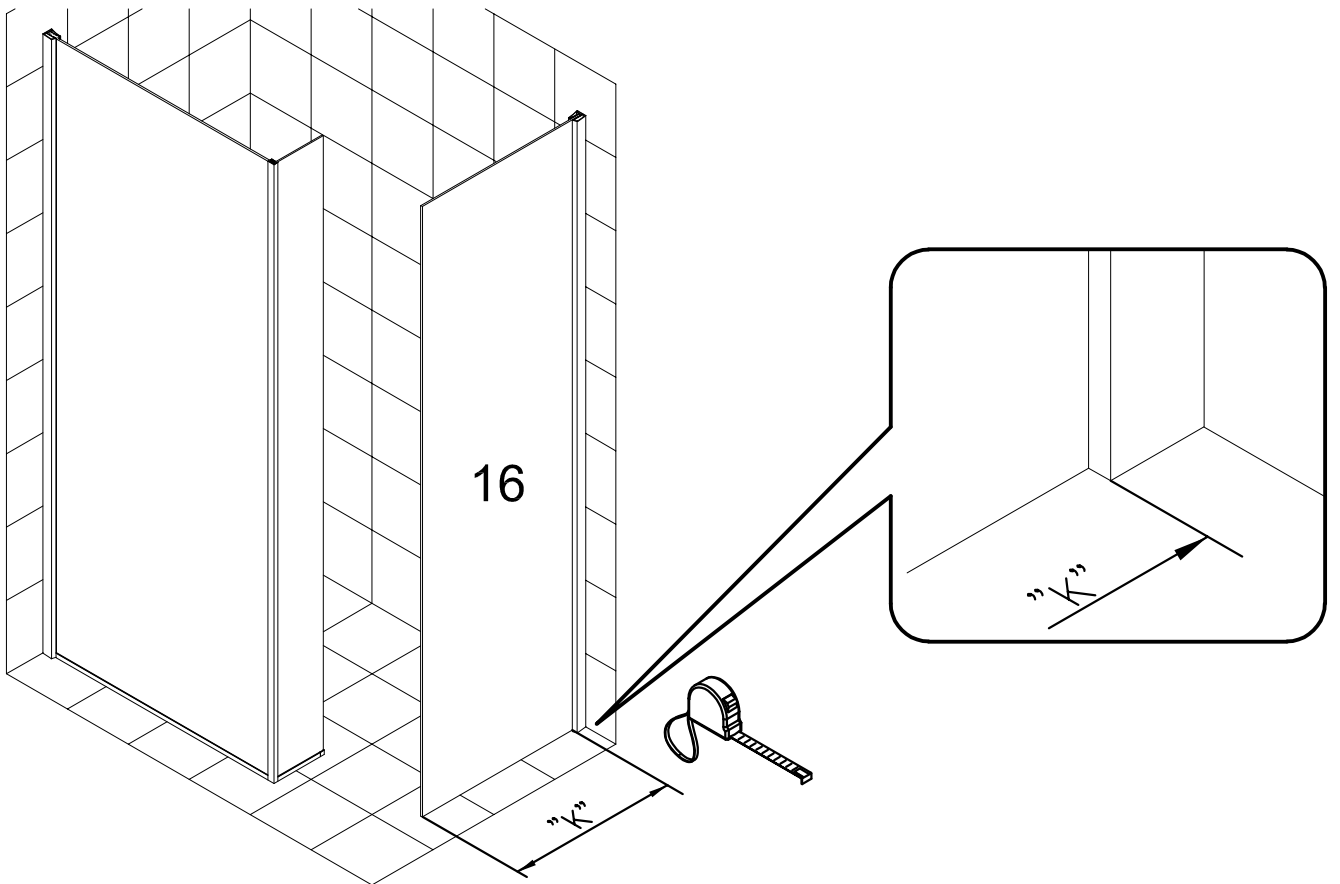

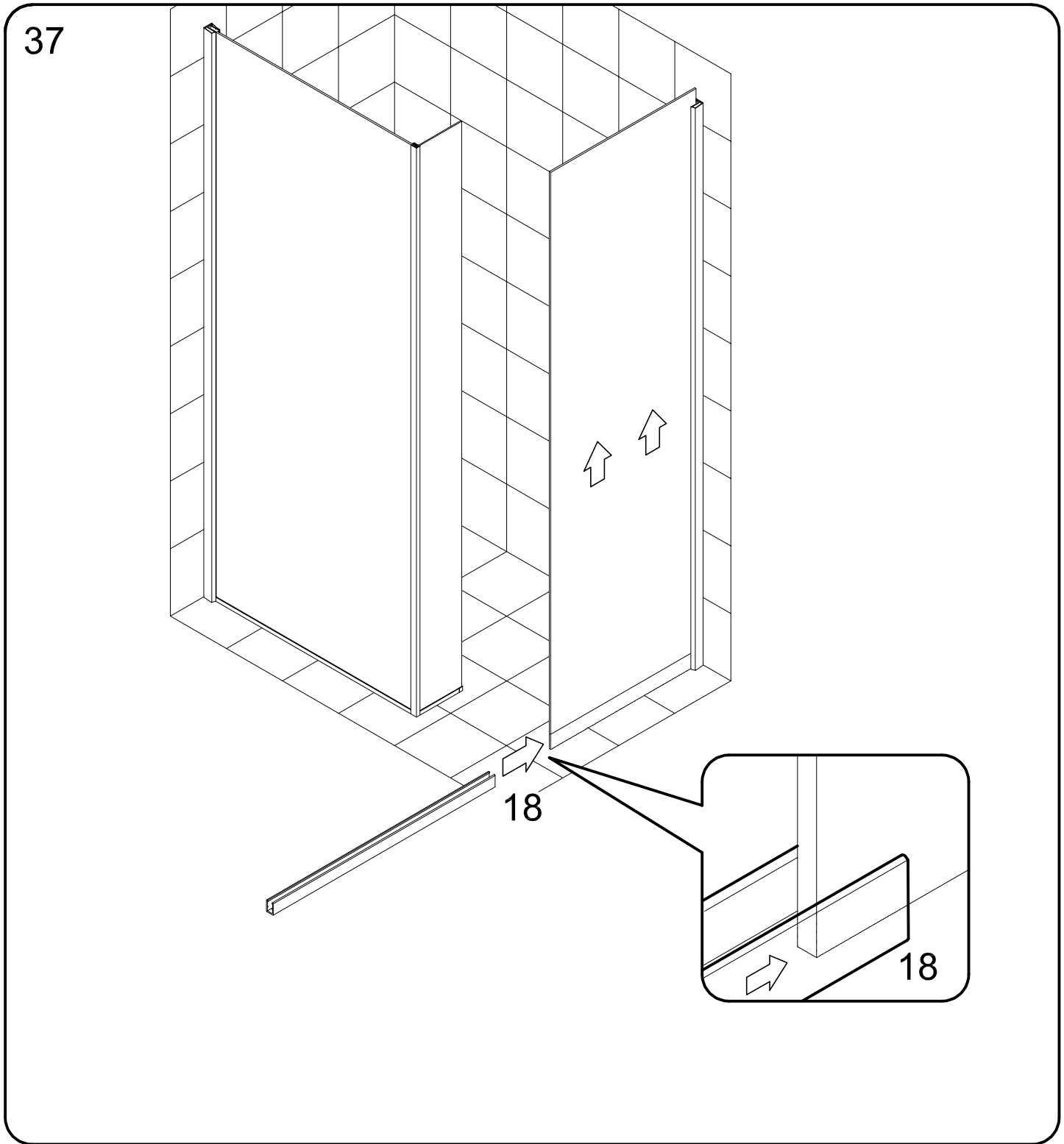
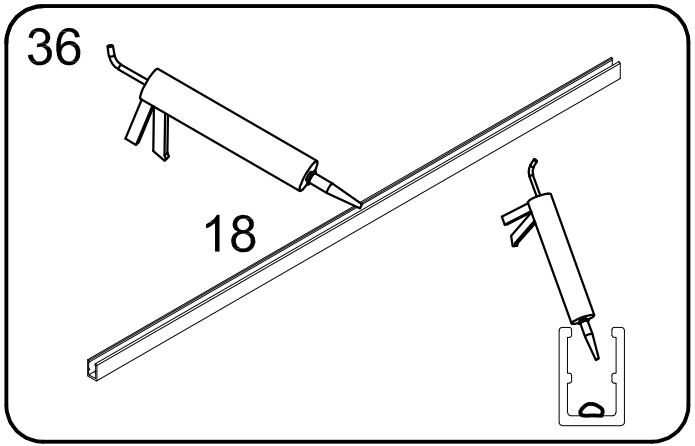
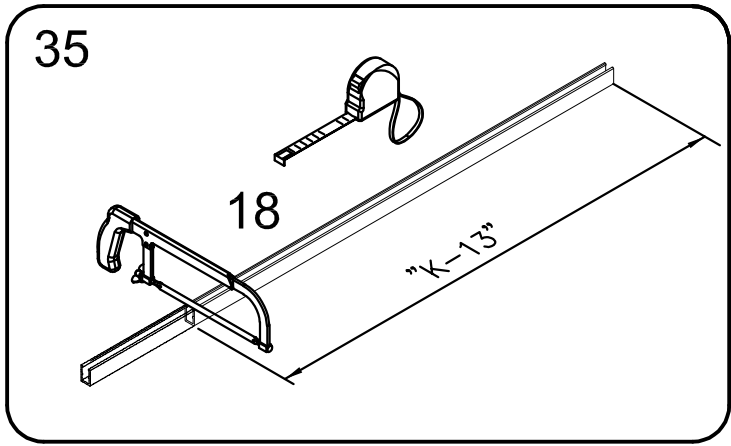

38

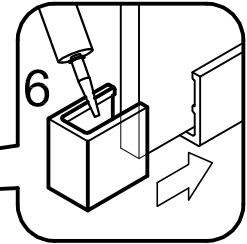
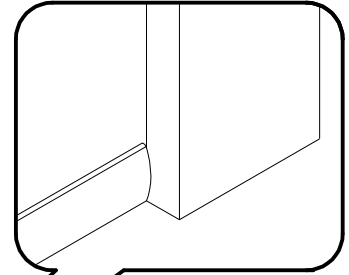
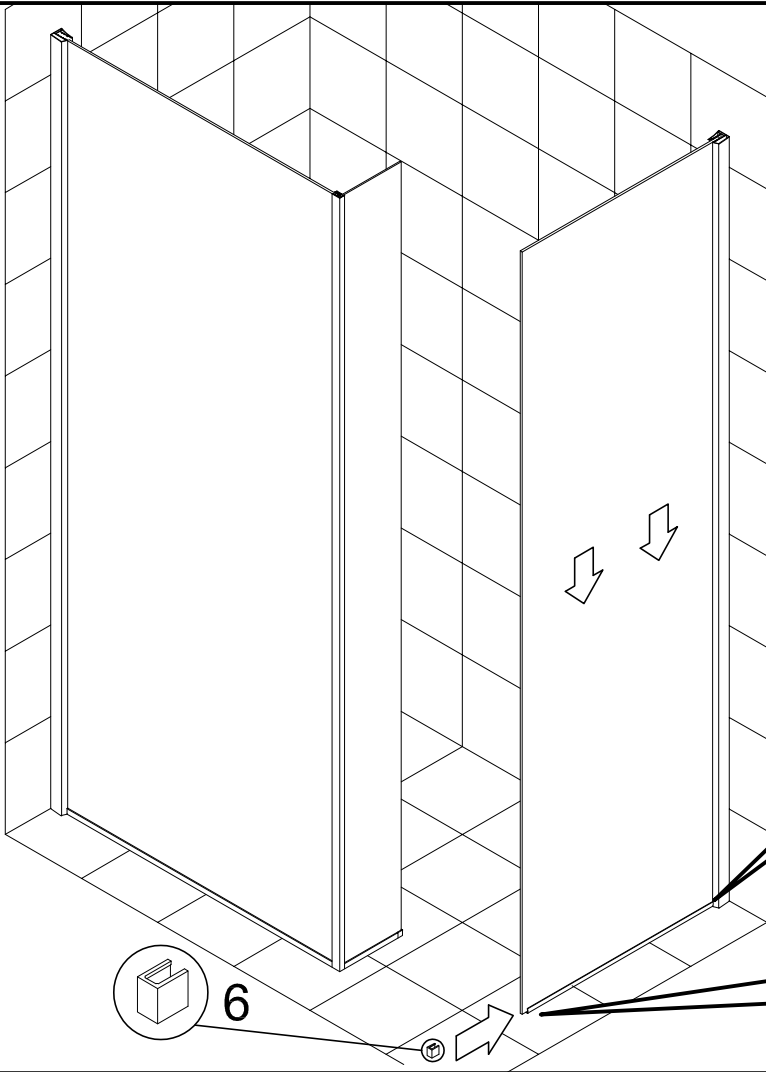

39

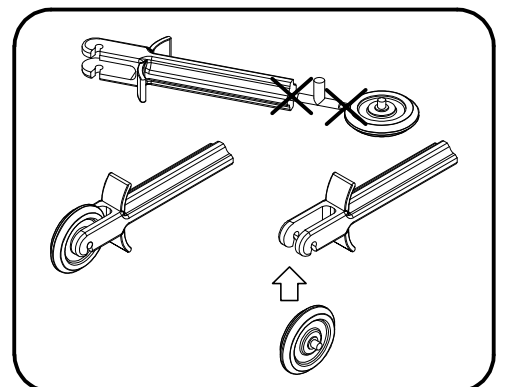
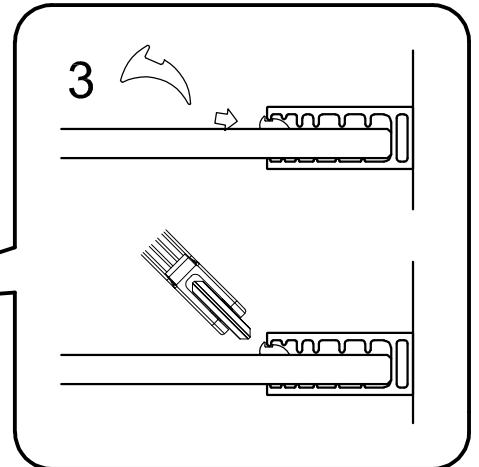
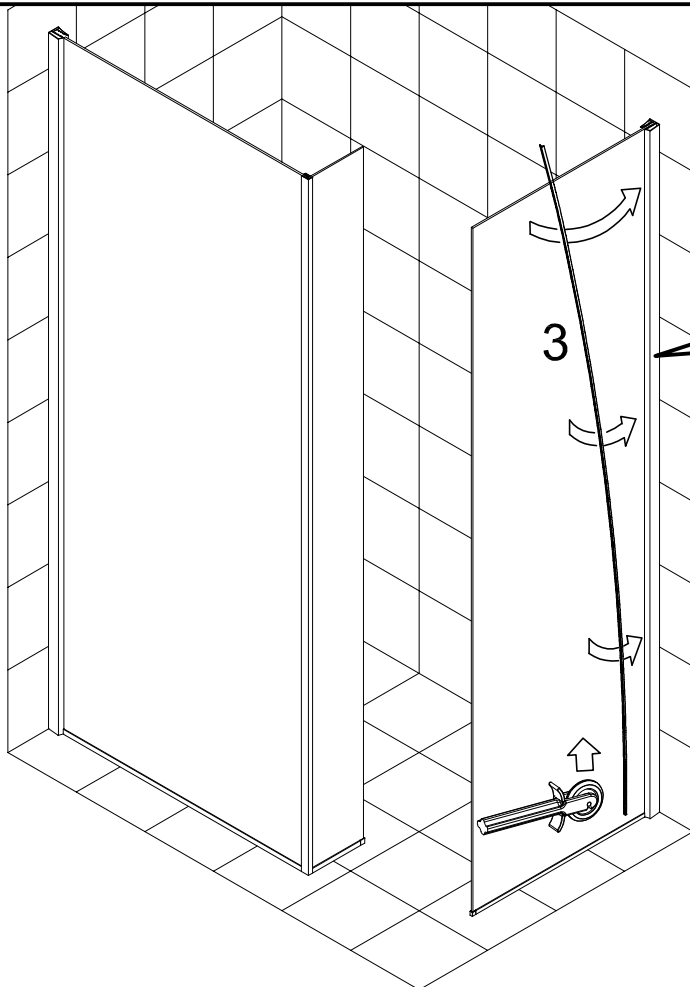

40

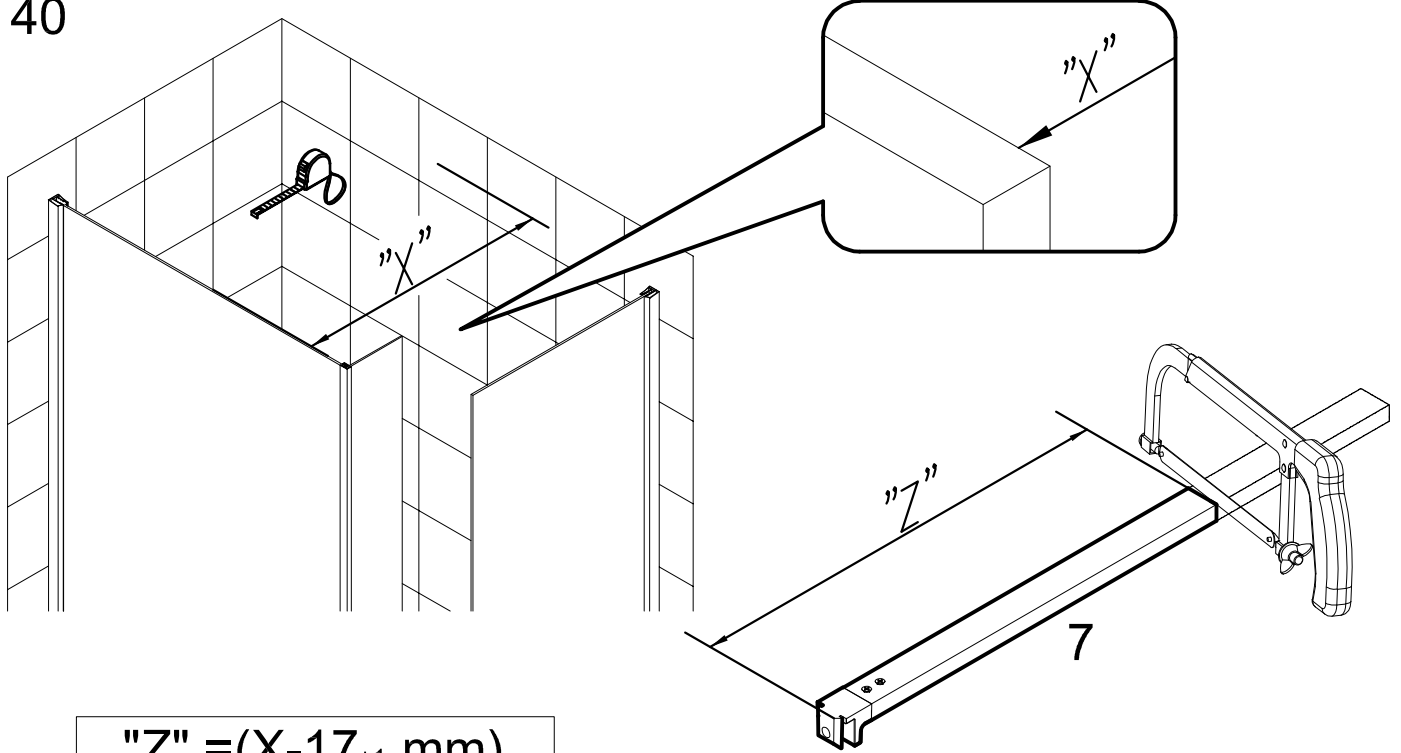

"Z" = (X - 17 ± 1 mm)

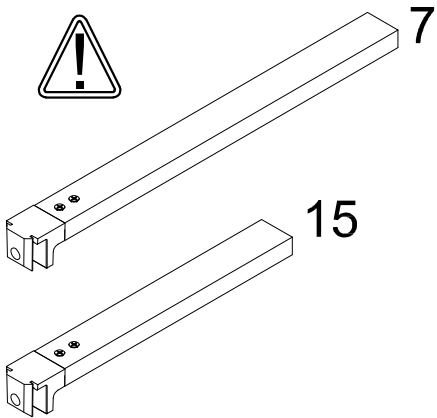

39

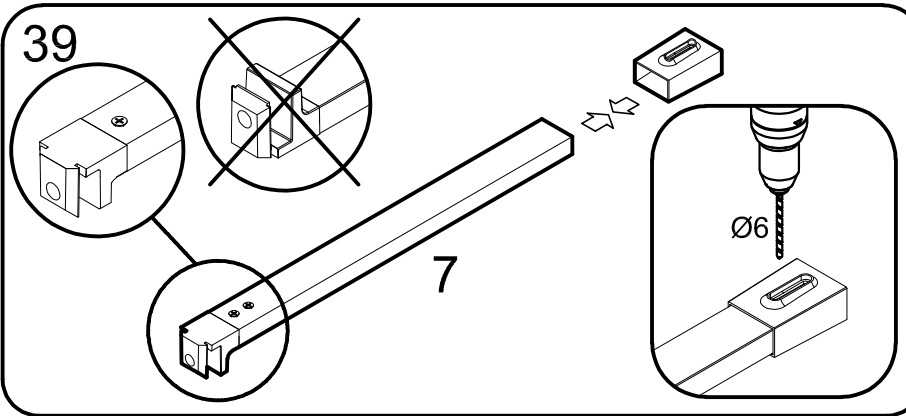

41

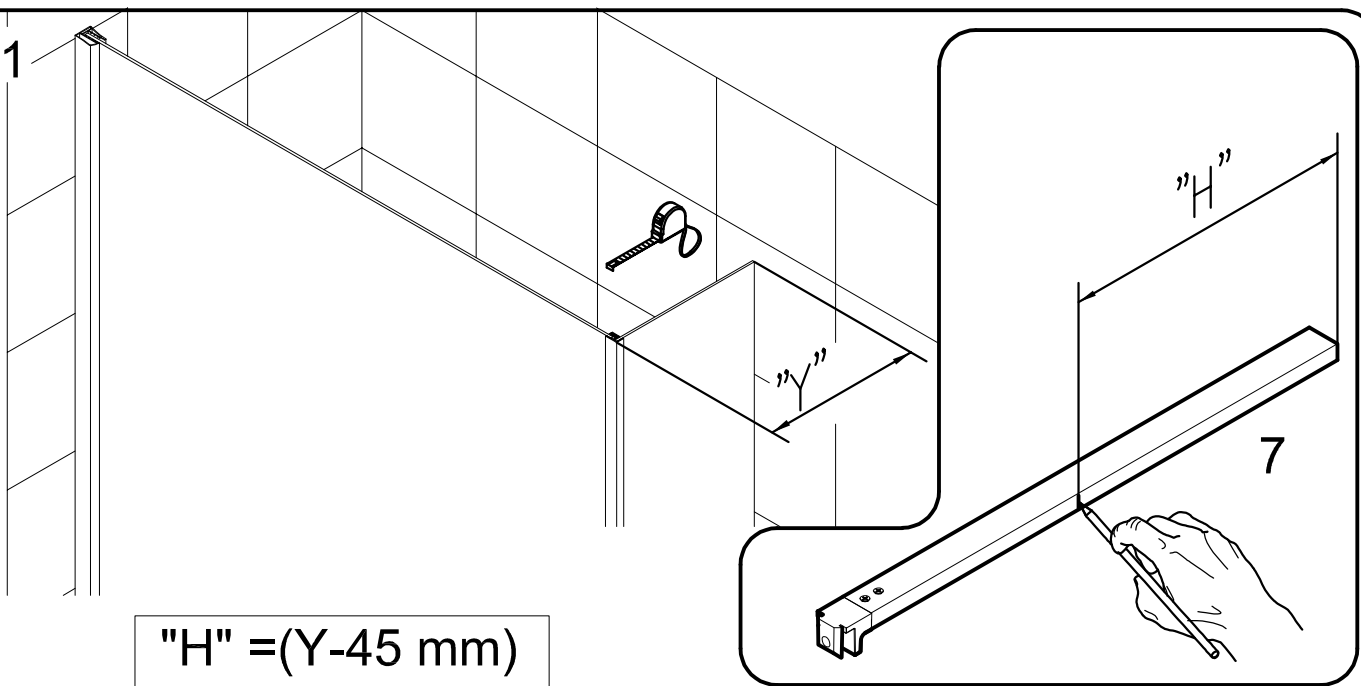

"H" = (Y - 45 mm)

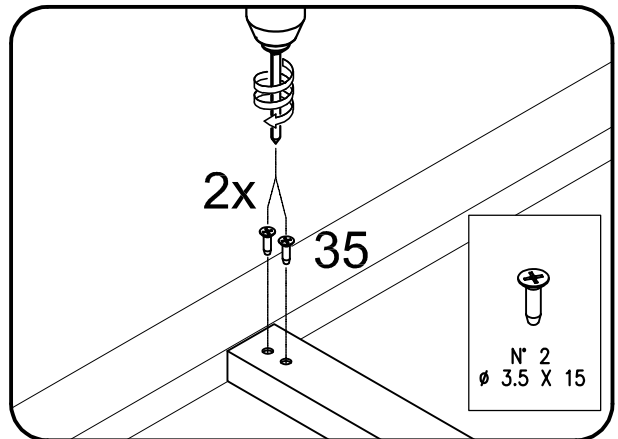
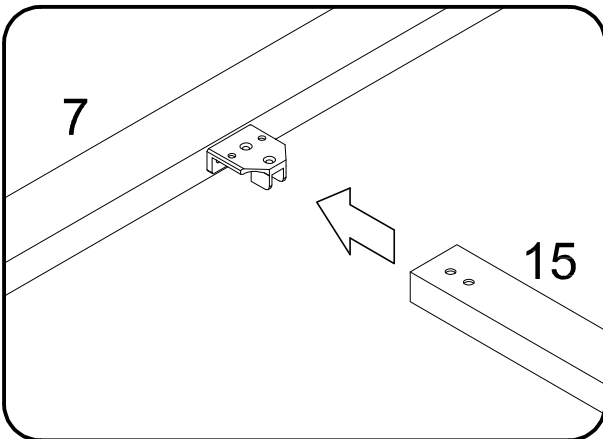
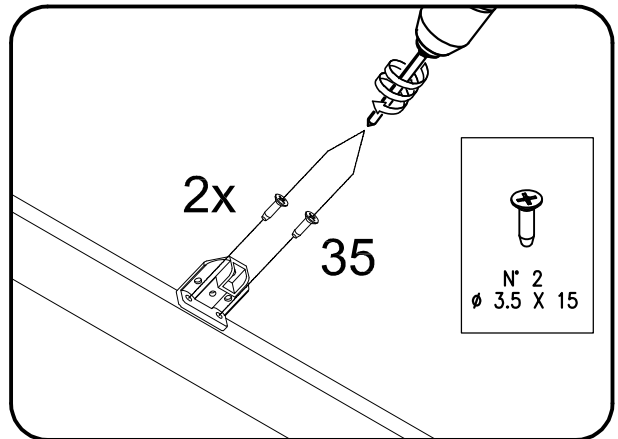
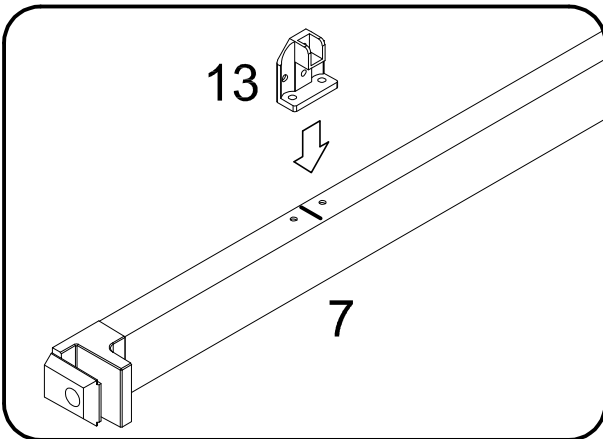
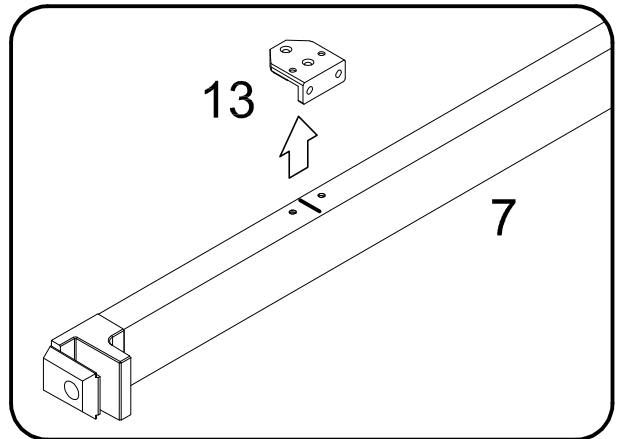
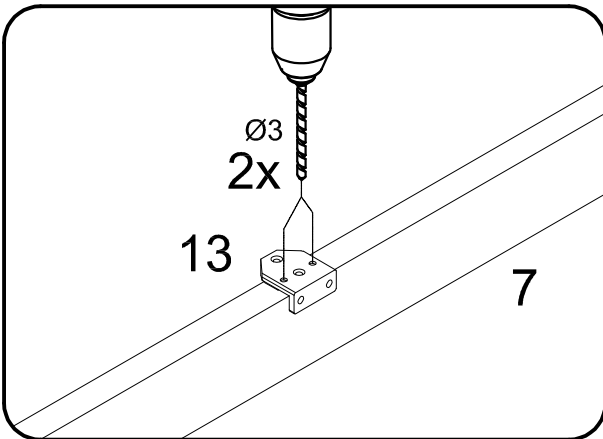
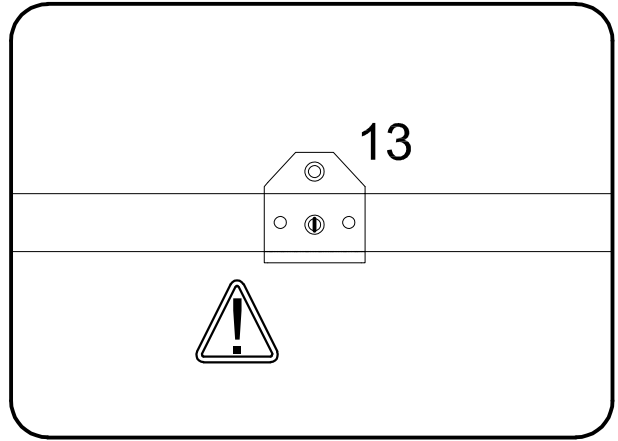
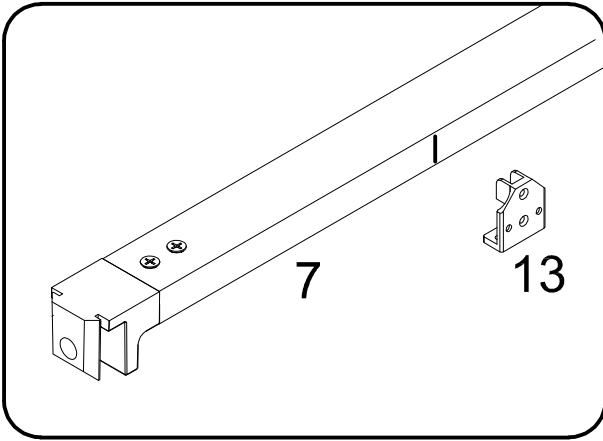

43

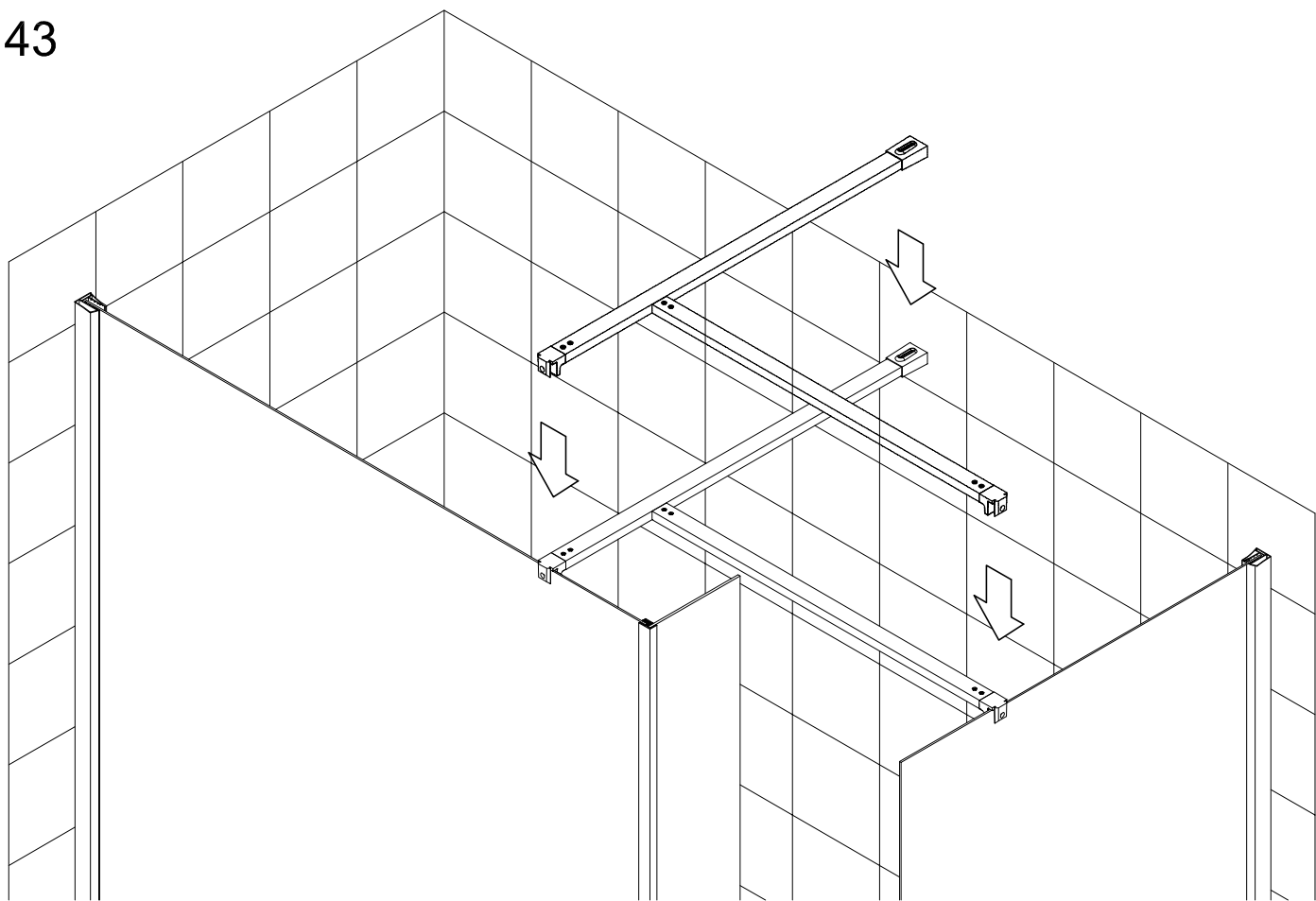

44

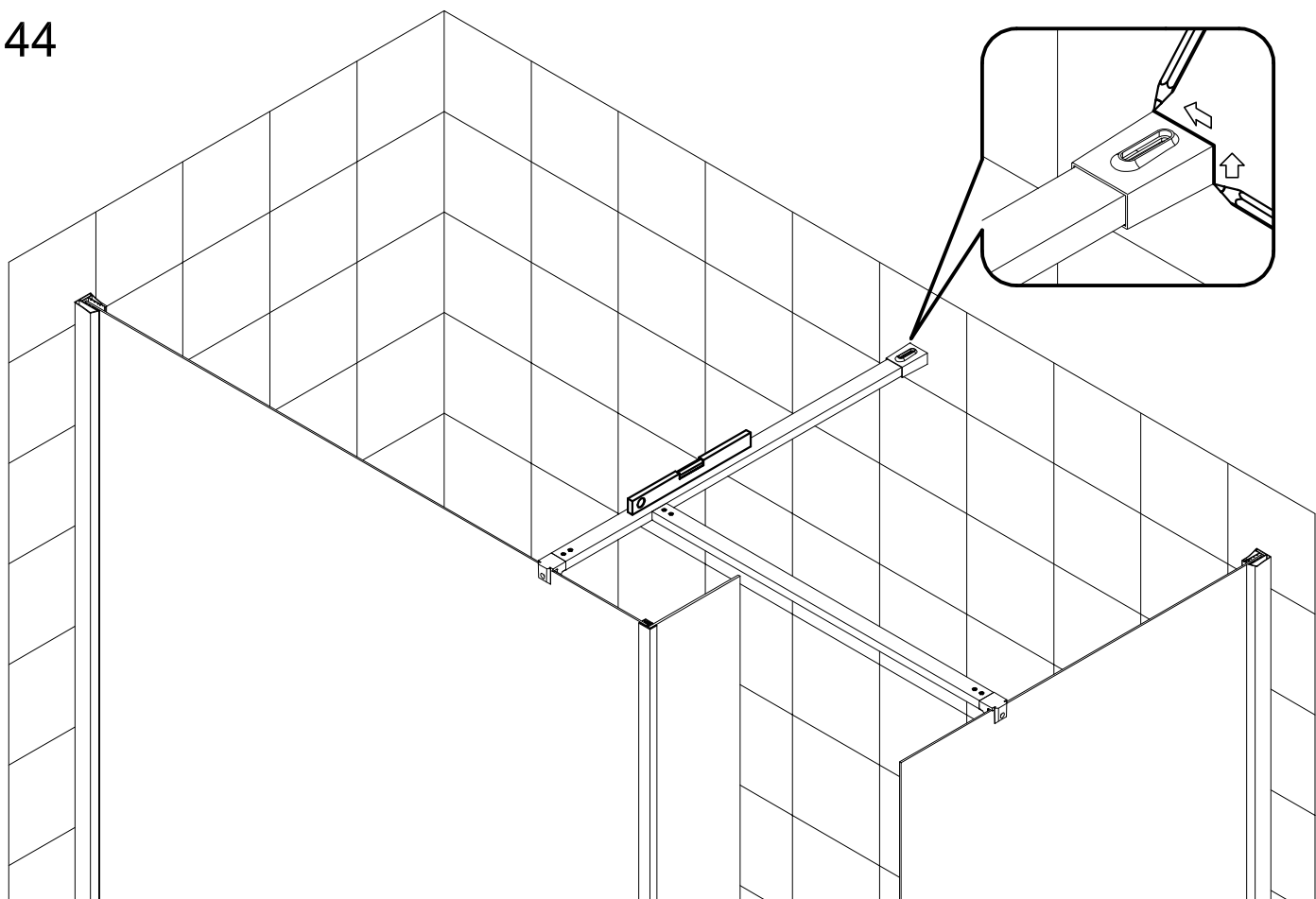

45

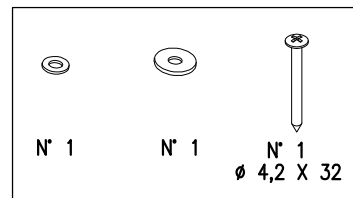
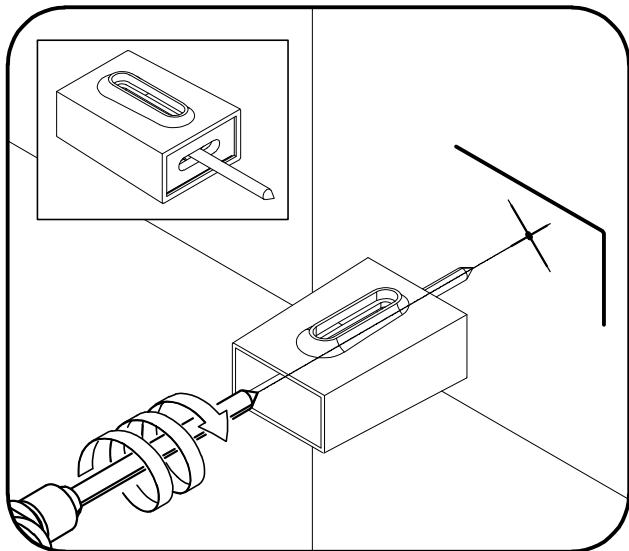
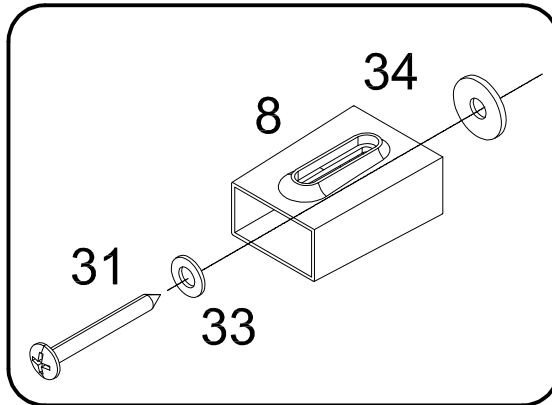
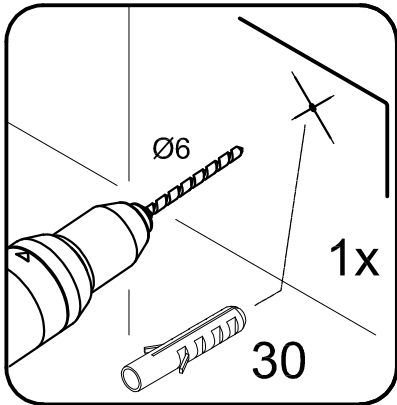
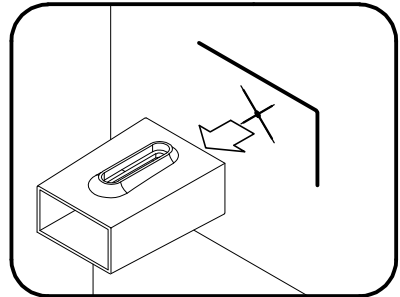
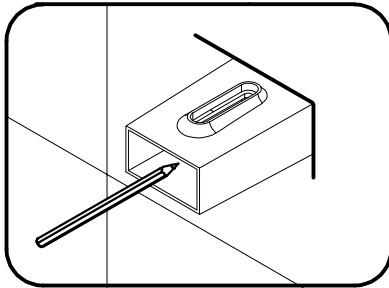
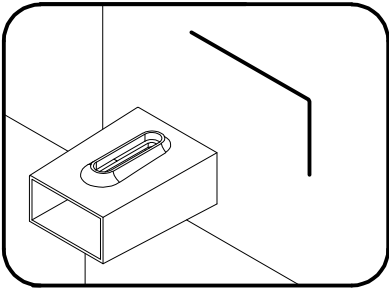
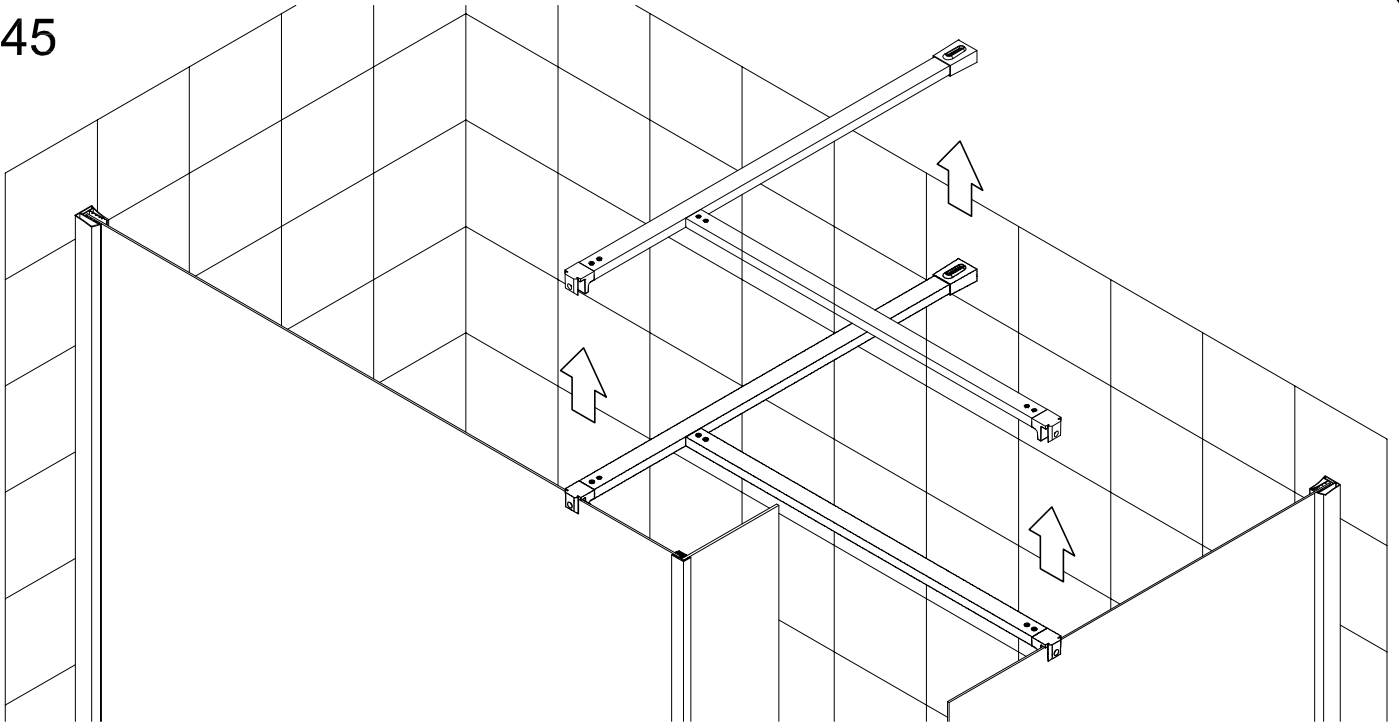

46

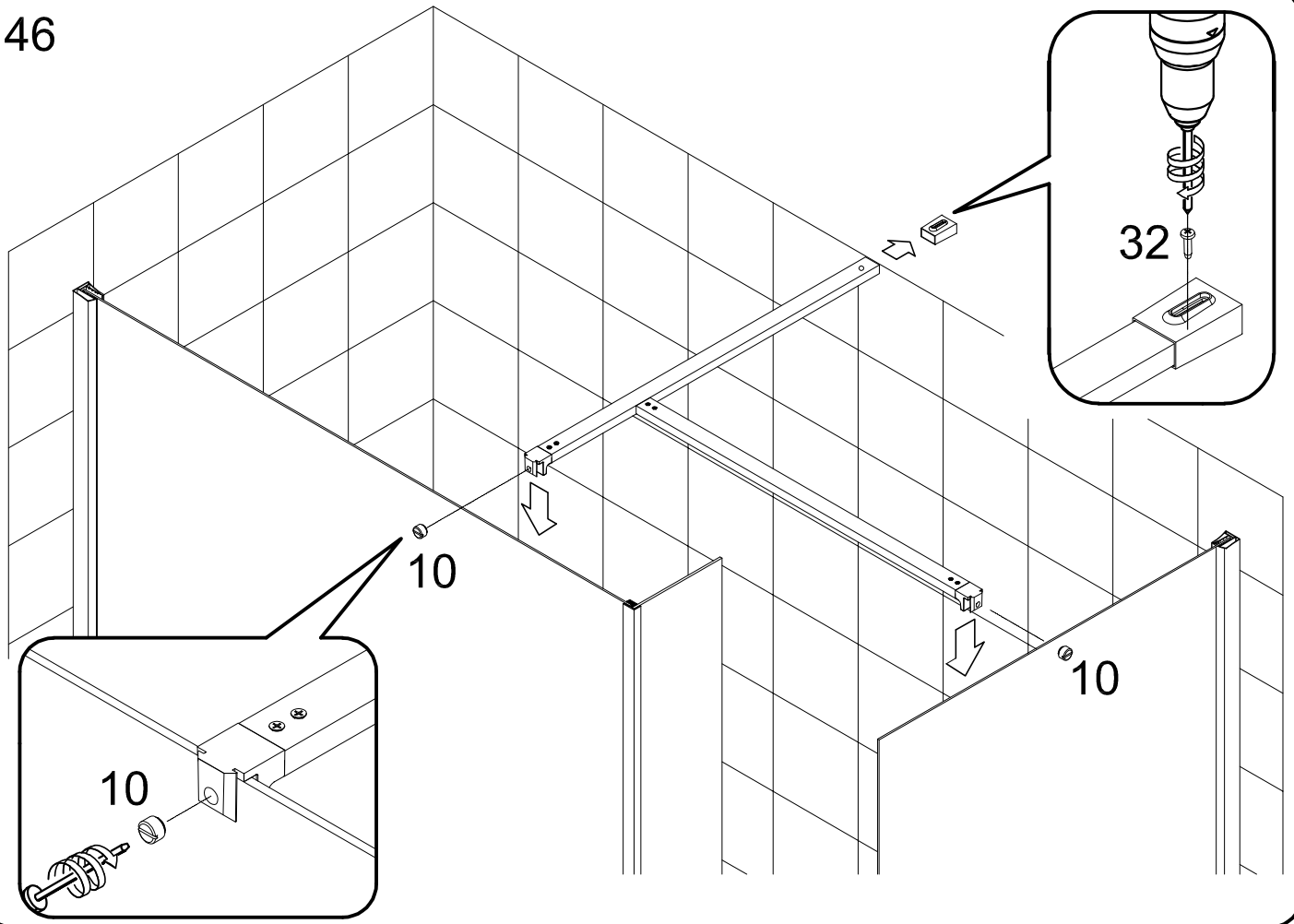

47

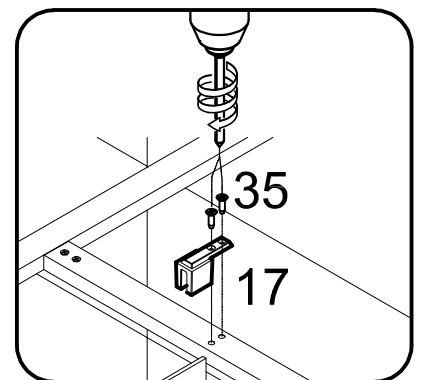
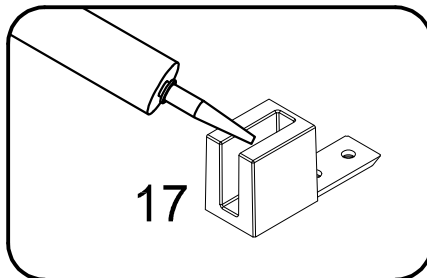
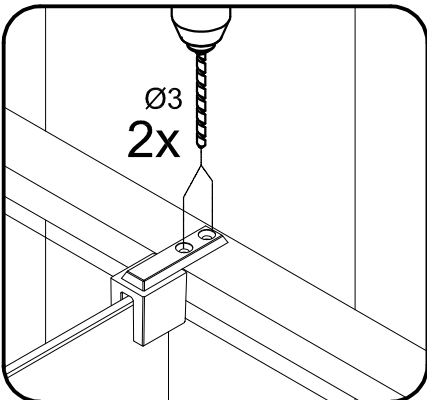
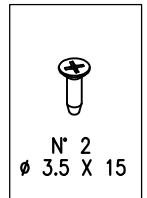
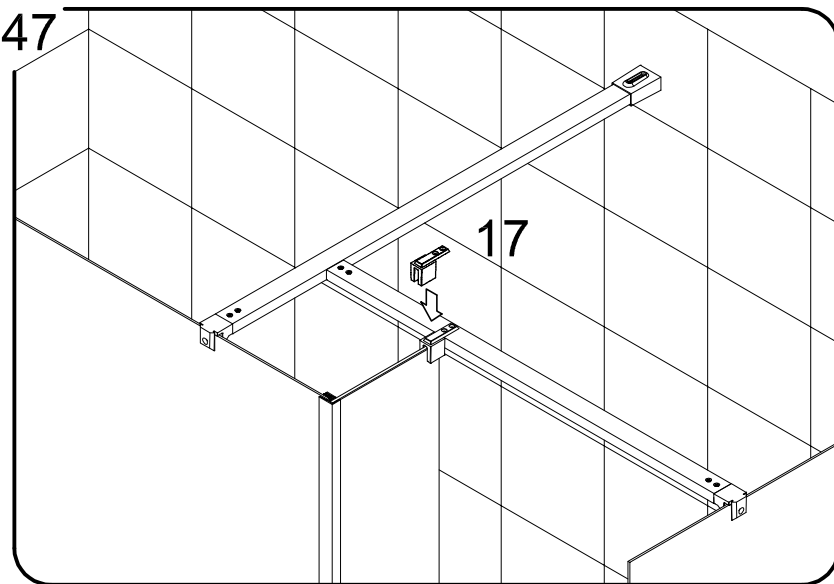

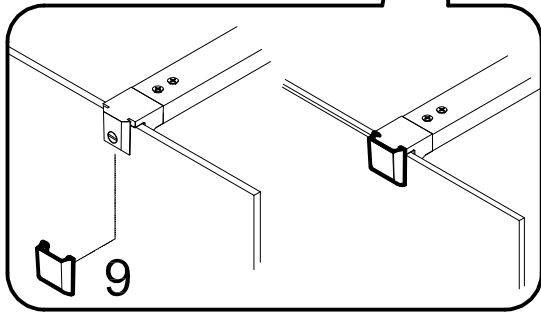
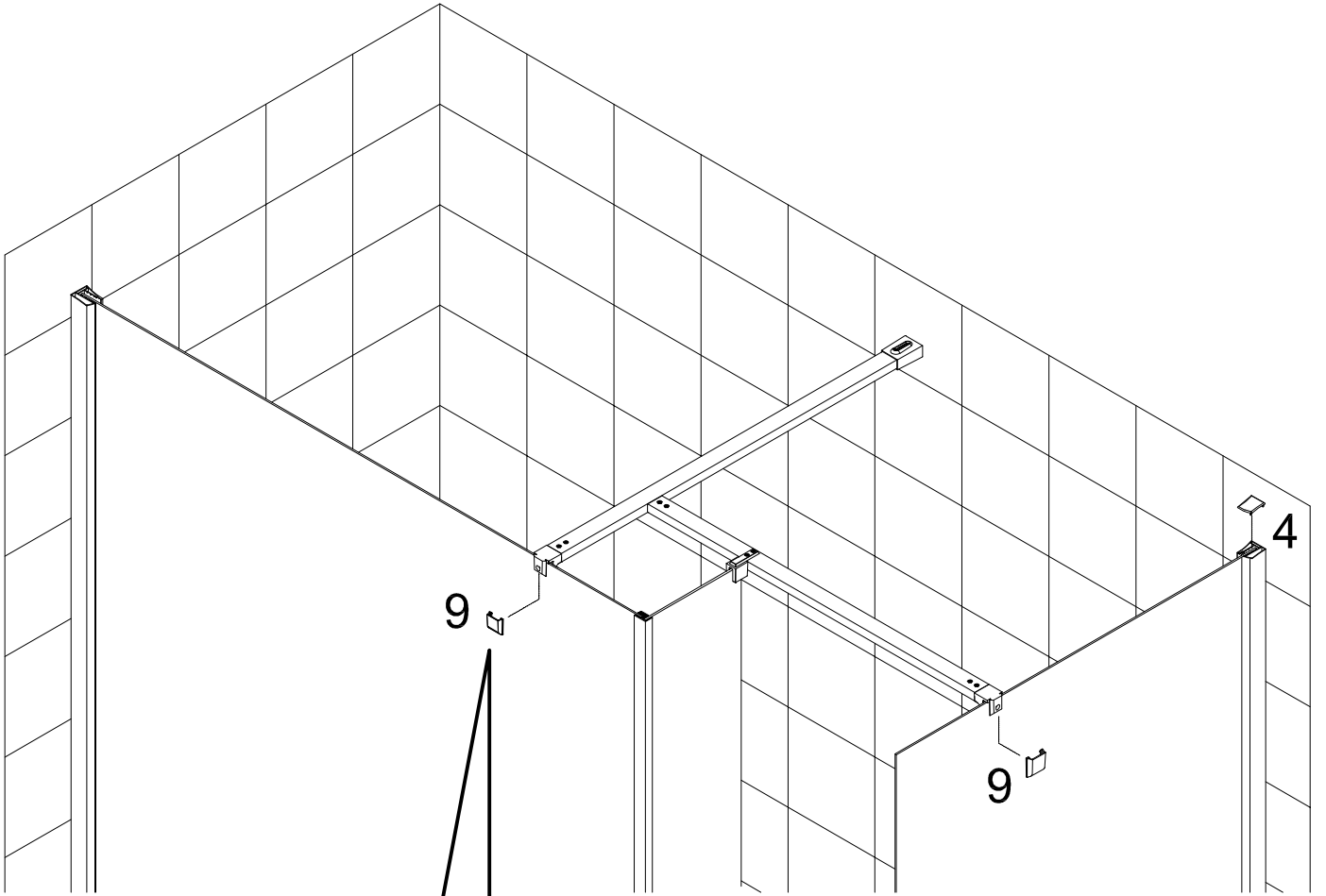



Pag. 1

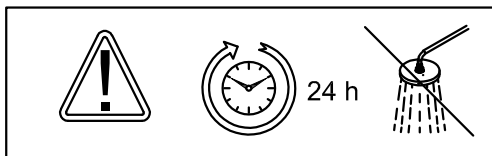
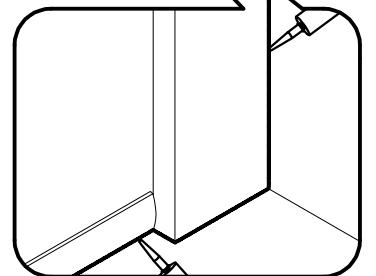
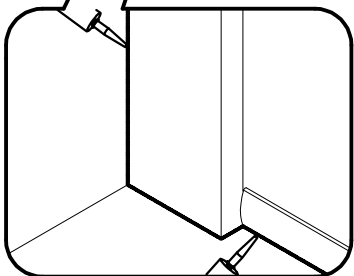
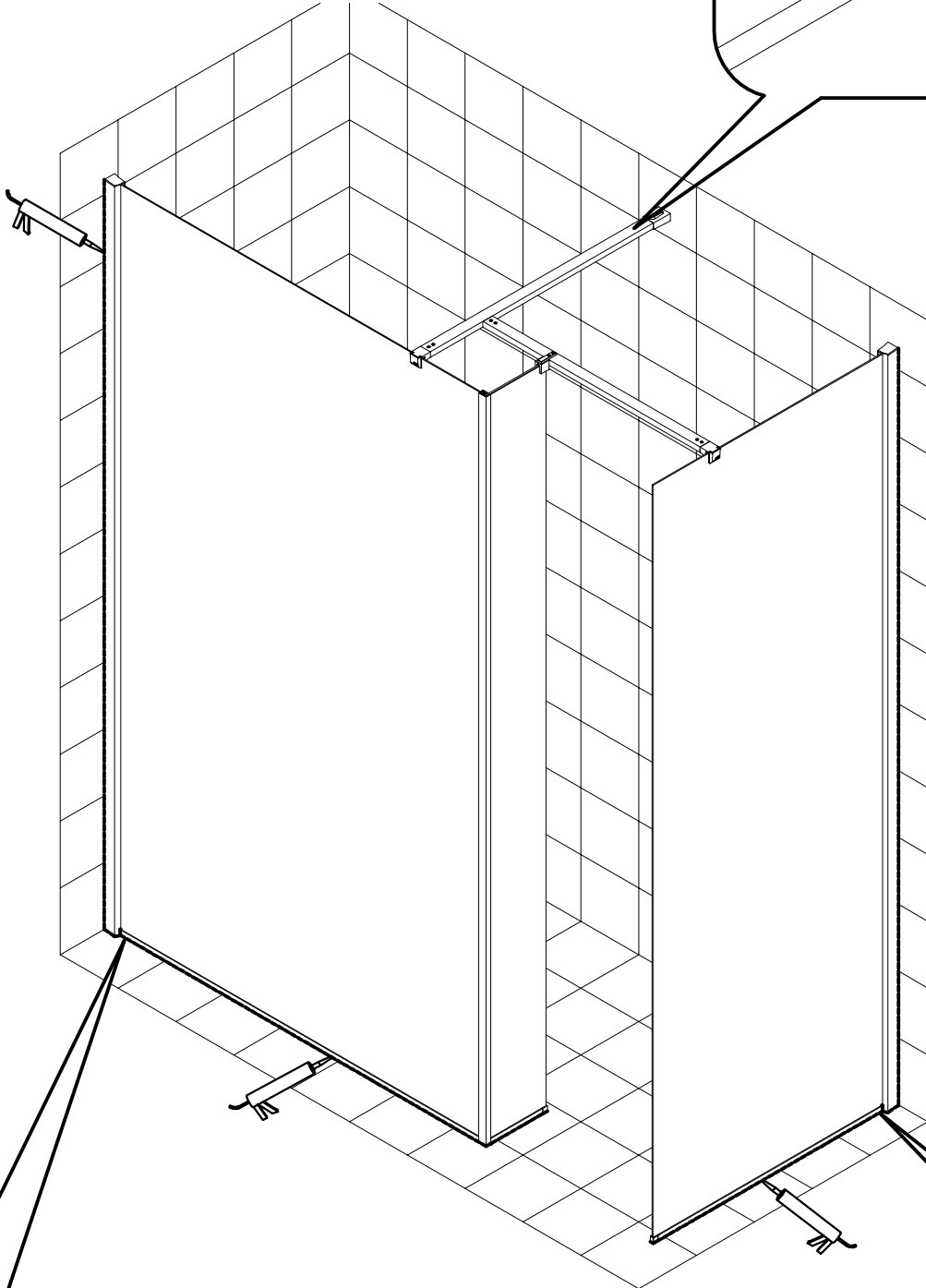
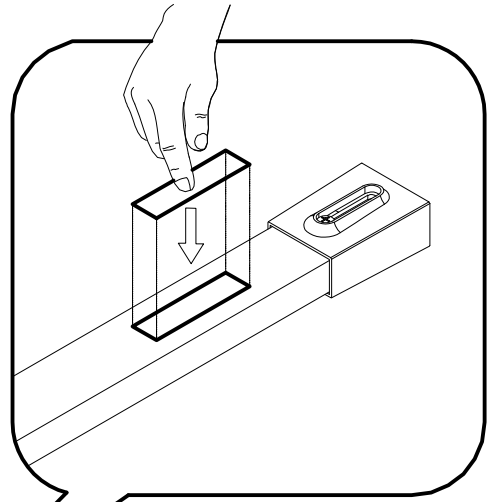
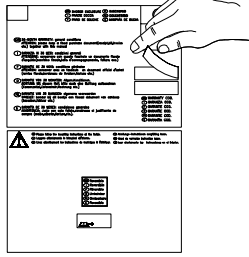

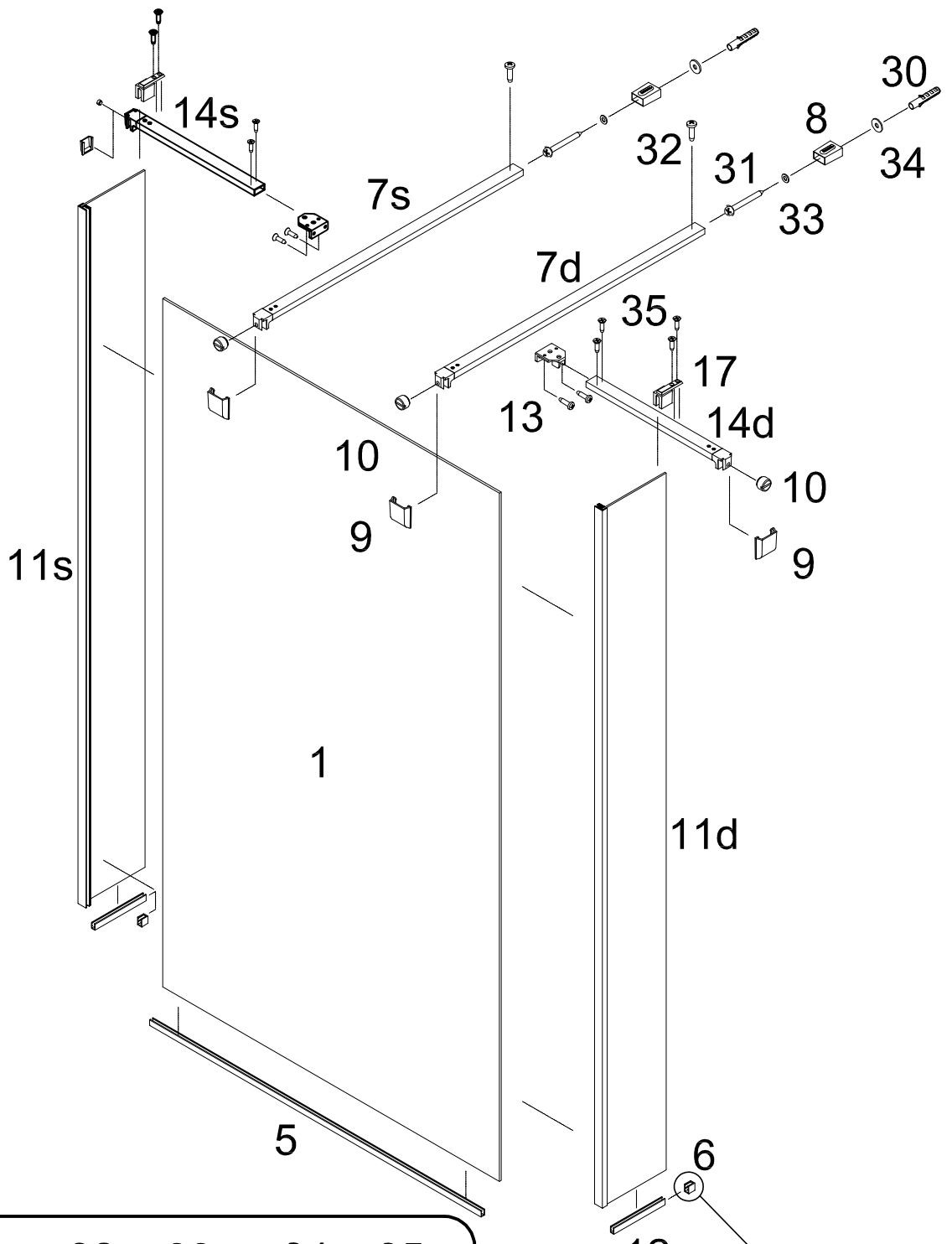

- | | | | | | |
|------------------|--------------------|--------------------|-----------|-----------|---------------------|
| 30 | 31 | 32 | 33 | 34 | 35 |
| | | | | | |
| N° 2
∅ 6 X 30 | N° 2
∅ 4,2 X 32 | N° 2
∅ 3,5 X 13 | N° 2 | N° 2 | N° 12
∅ 3,5 X 13 |

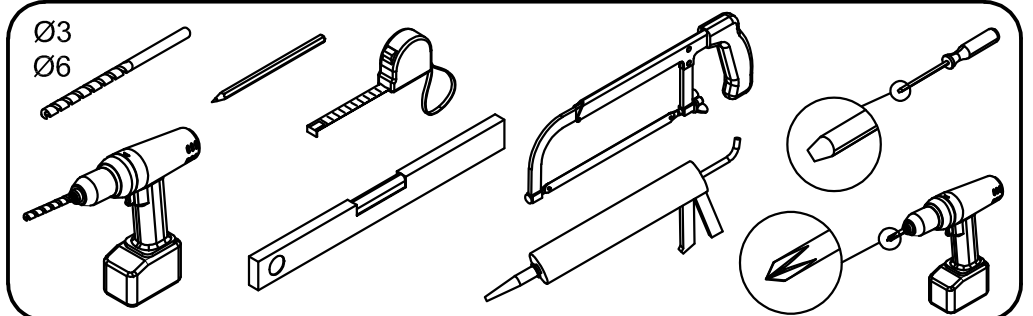
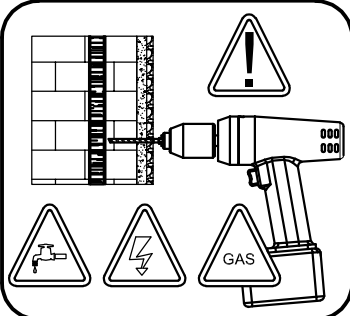

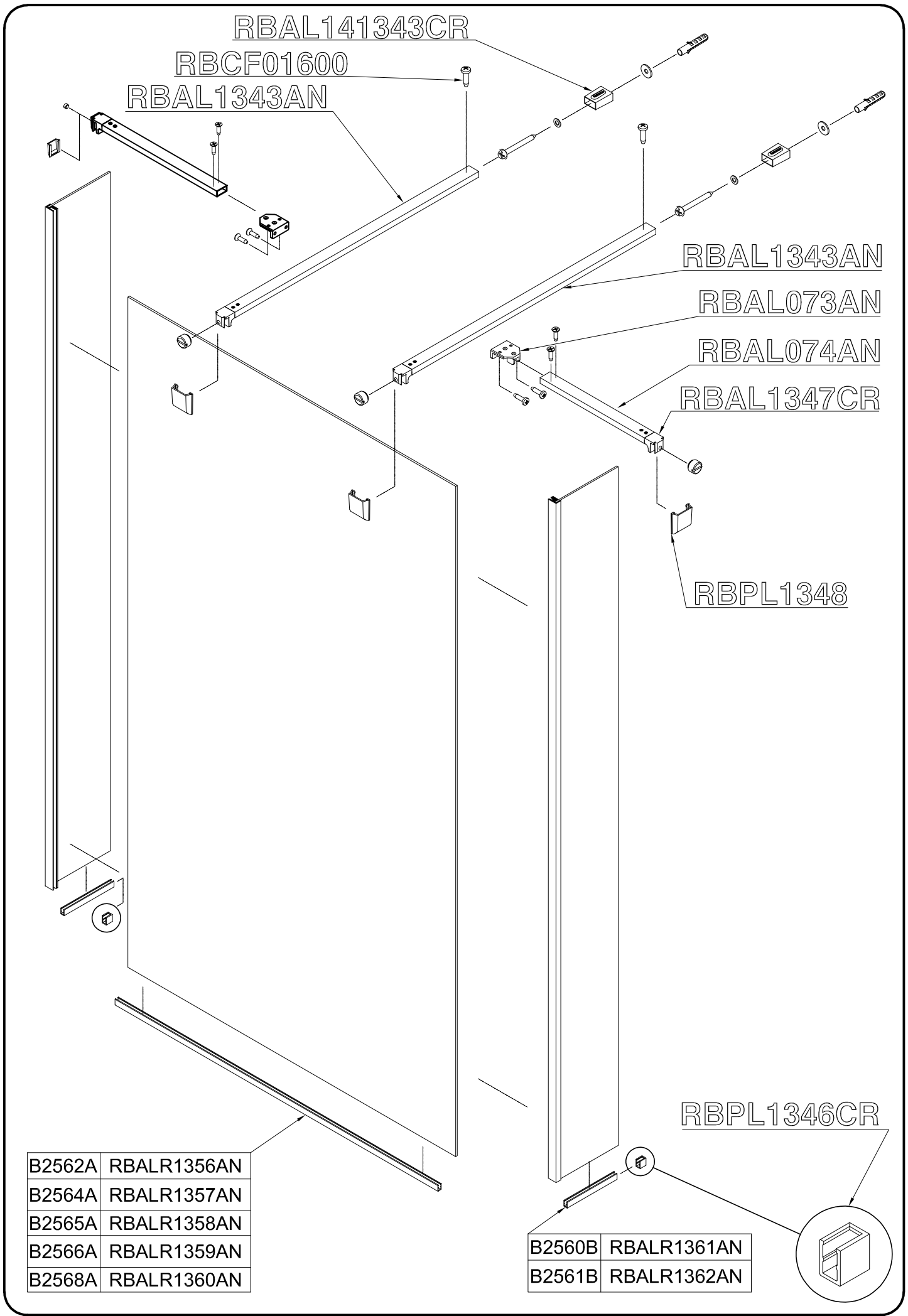

RBAL141343CR

RBCF01600

RBAL1343AN

RBAL1343AN

RBAL073AN

RBAL074AN

RBAL1347CR

RBPL1348

RBPL1346CR

B2562A	RBALR1356AN
B2564A	RBALR1357AN
B2565A	RBALR1358AN
B2566A	RBALR1359AN
B2568A	RBALR1360AN

B2560B	RBALR1361AN
B2561B	RBALR1362AN

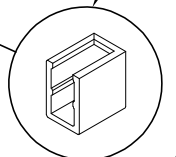

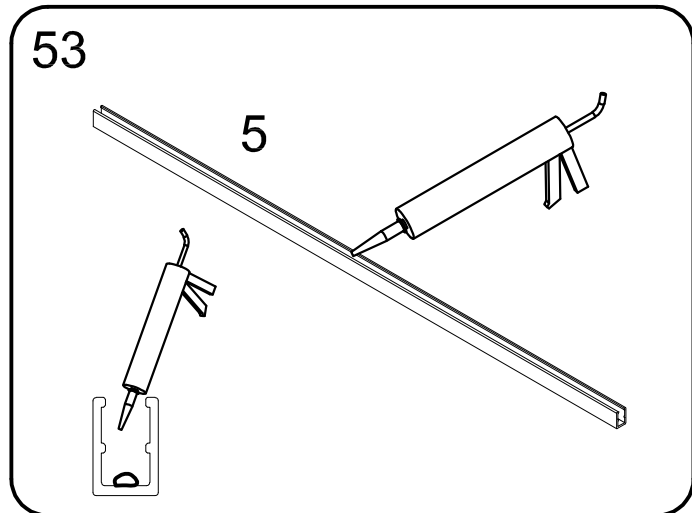
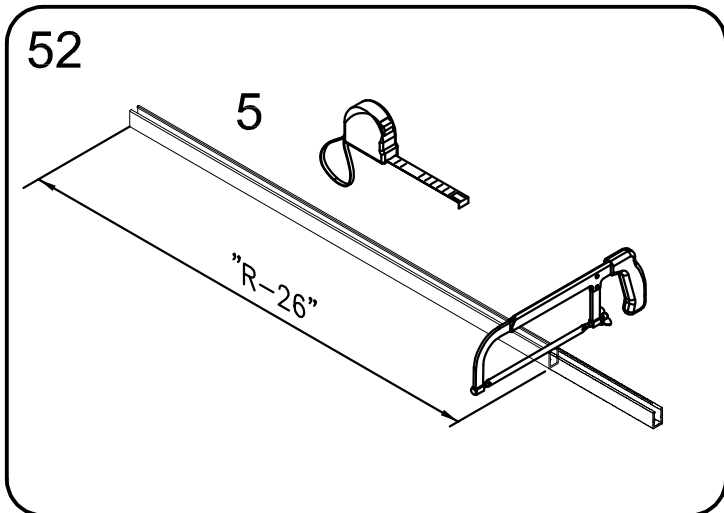
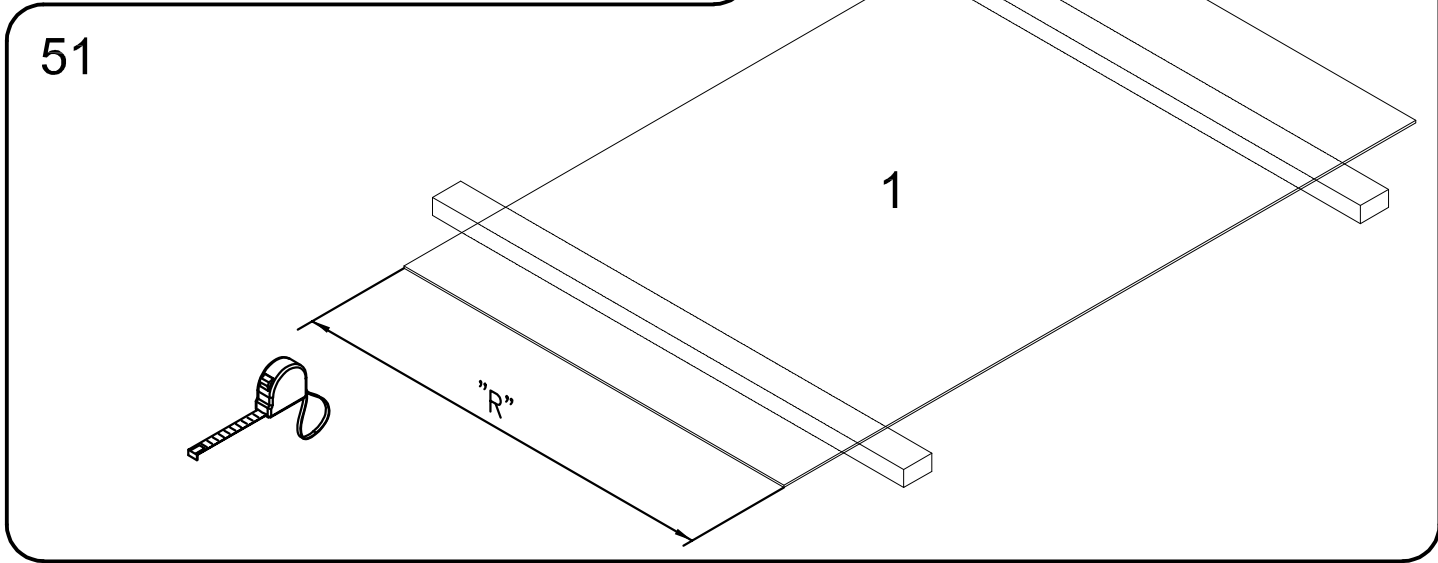
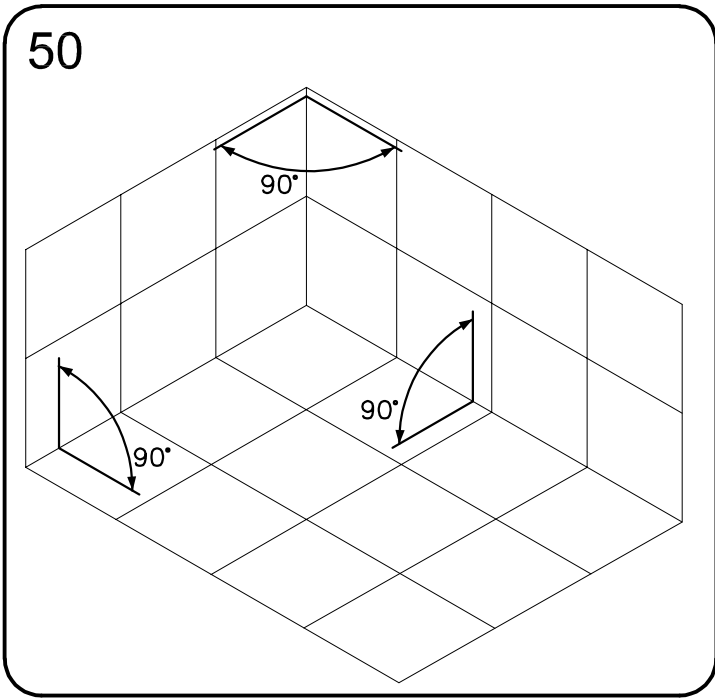
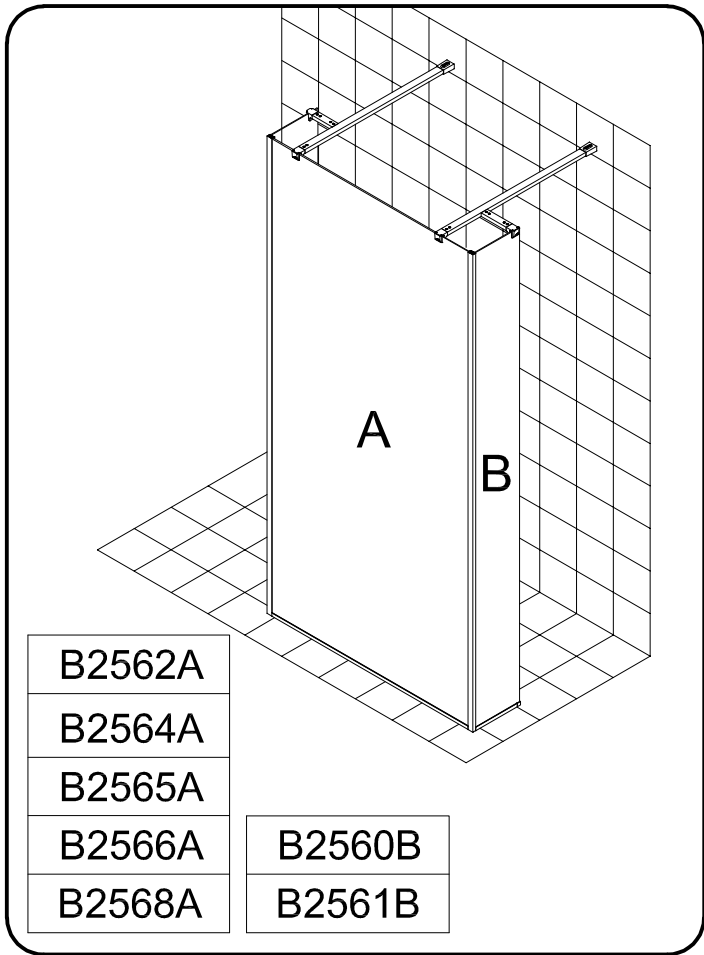

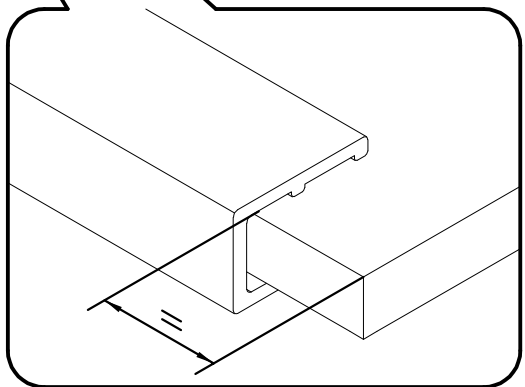
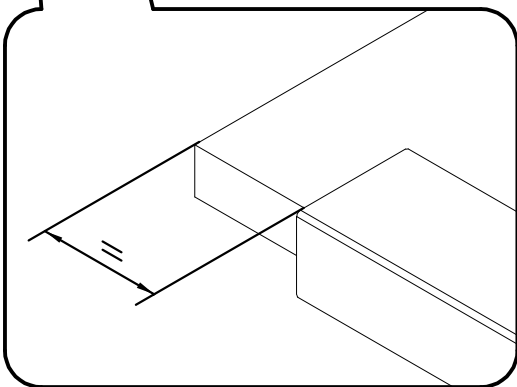
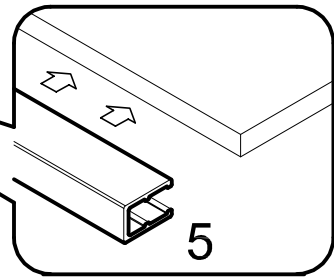
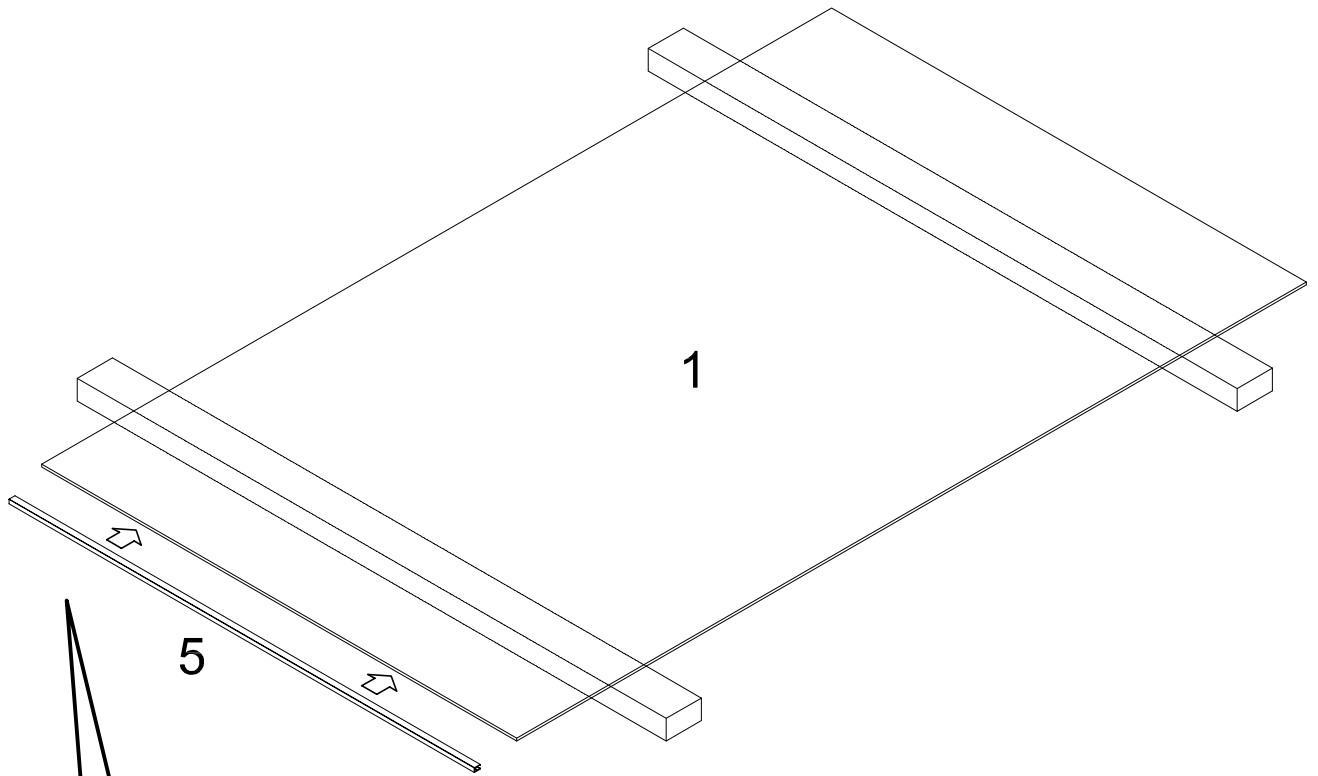

55

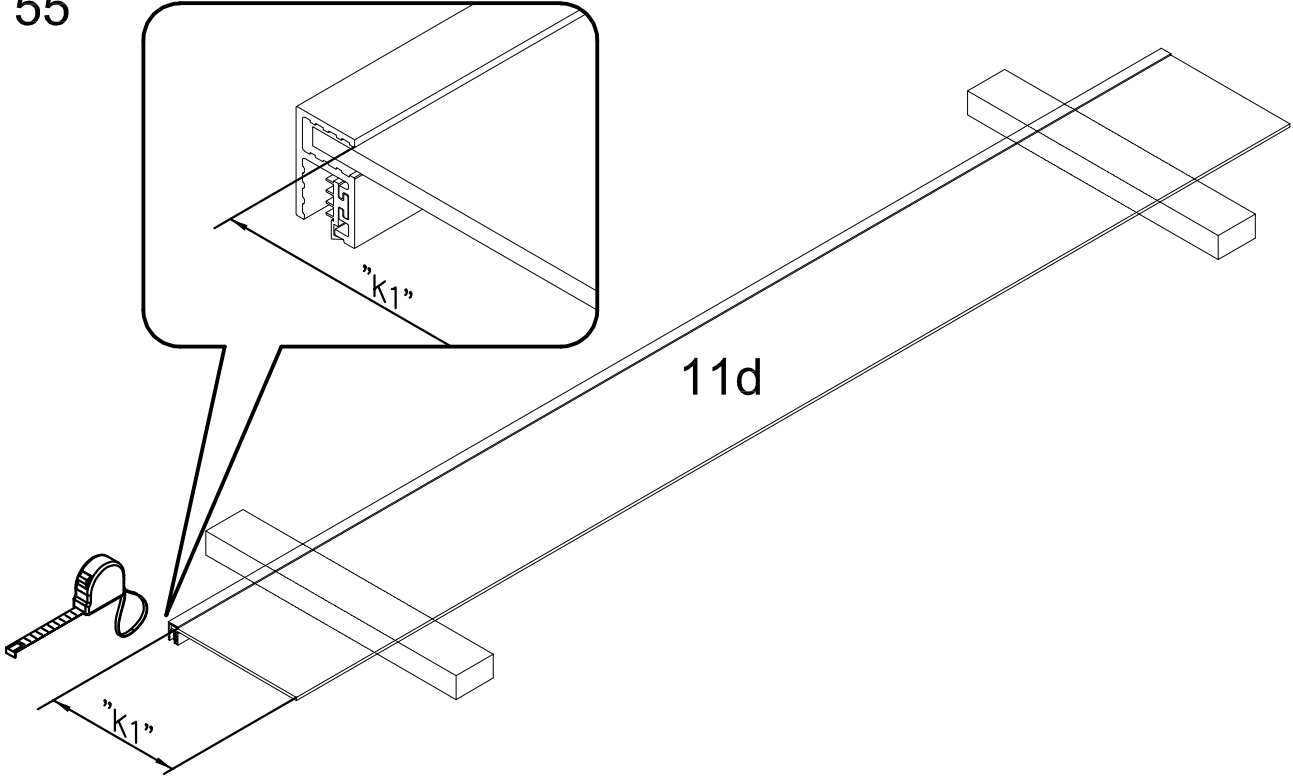

56

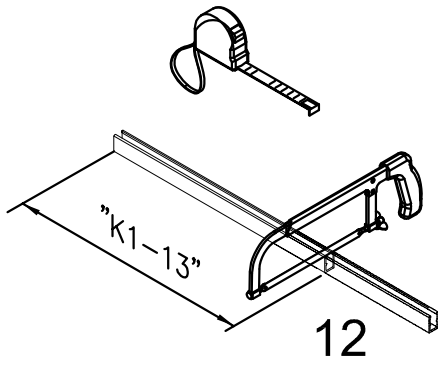

57

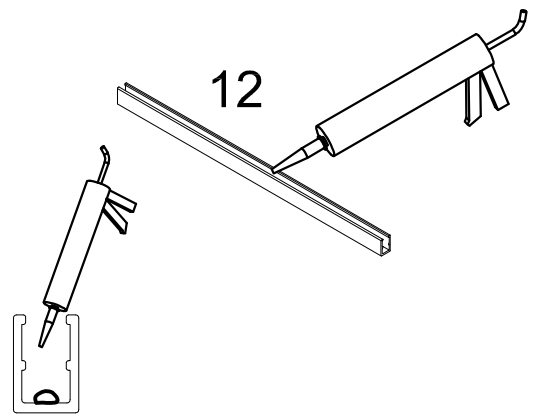

58

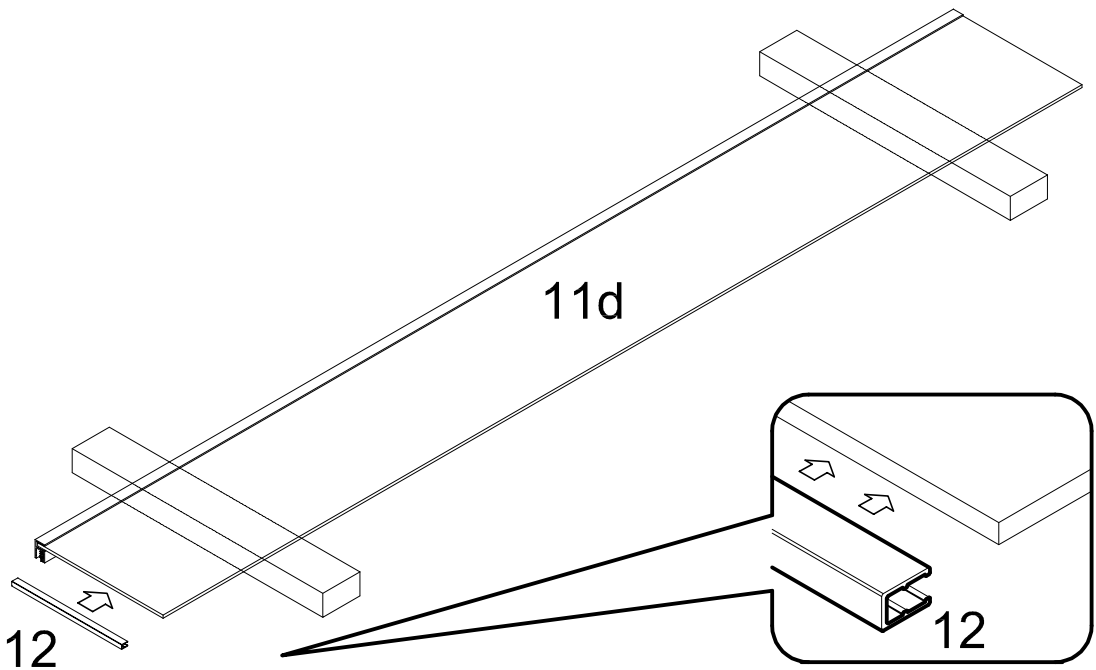

59

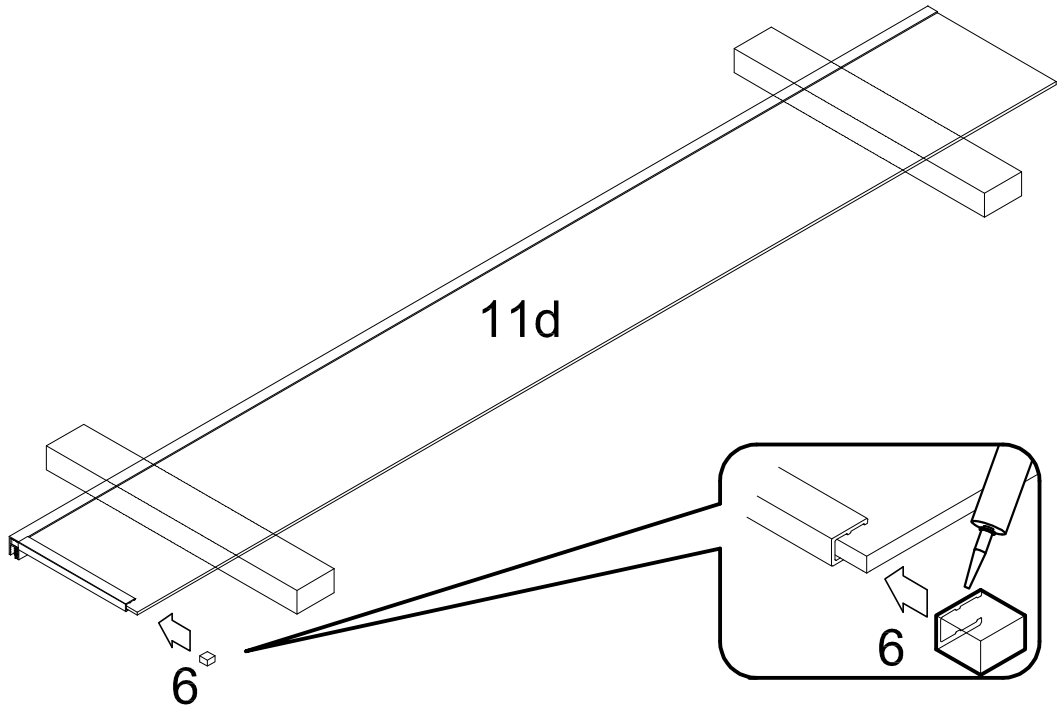

60

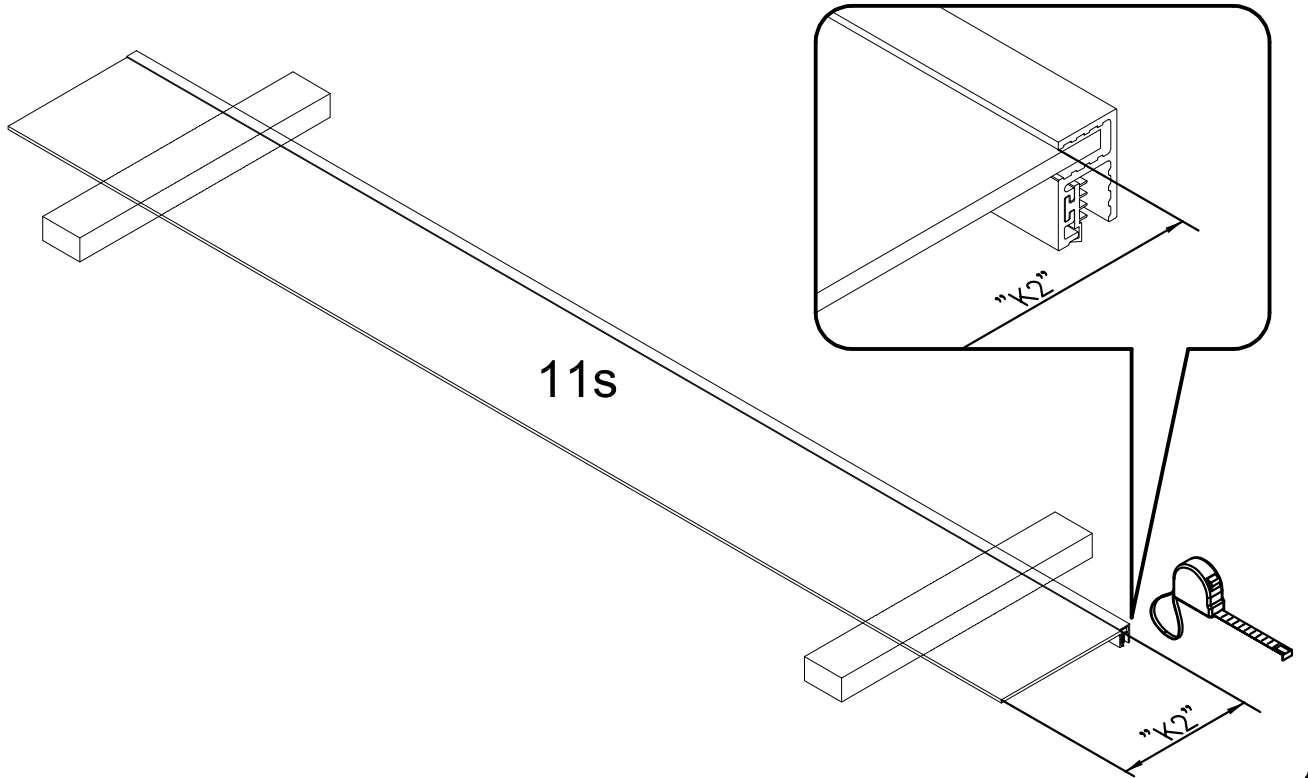

61

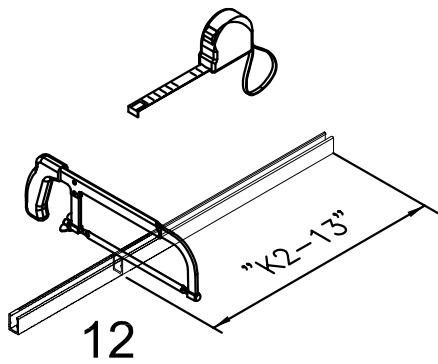

62

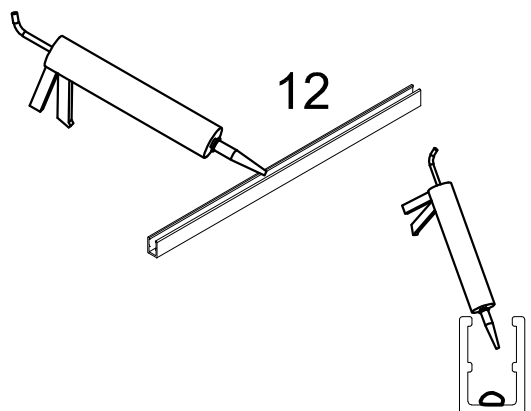

63

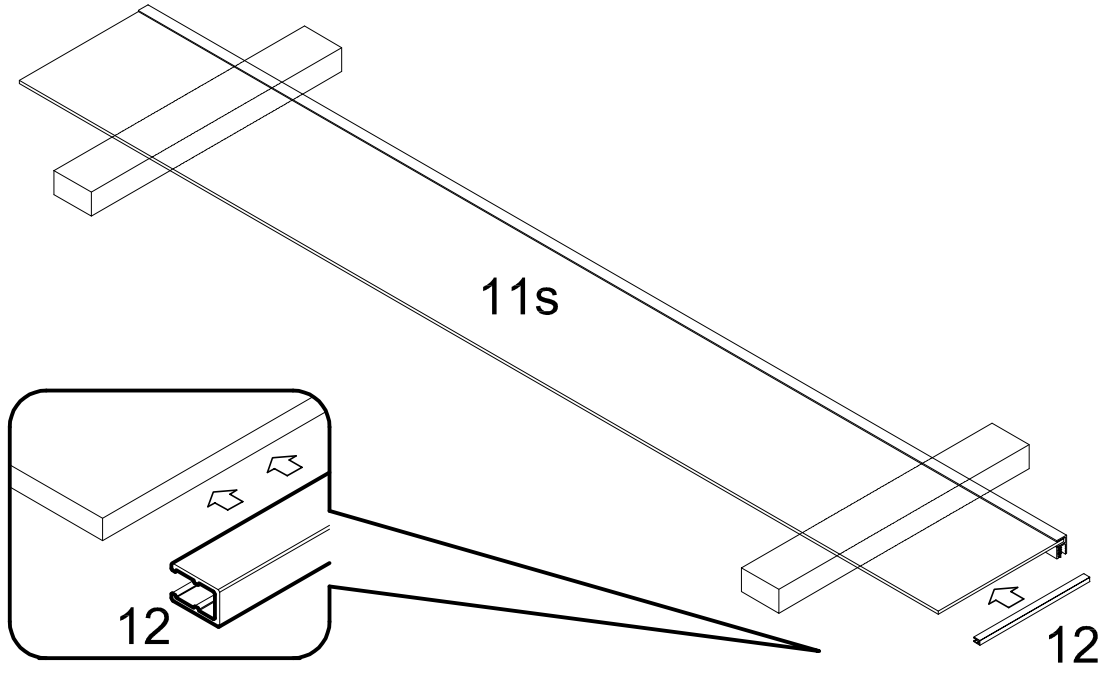

64

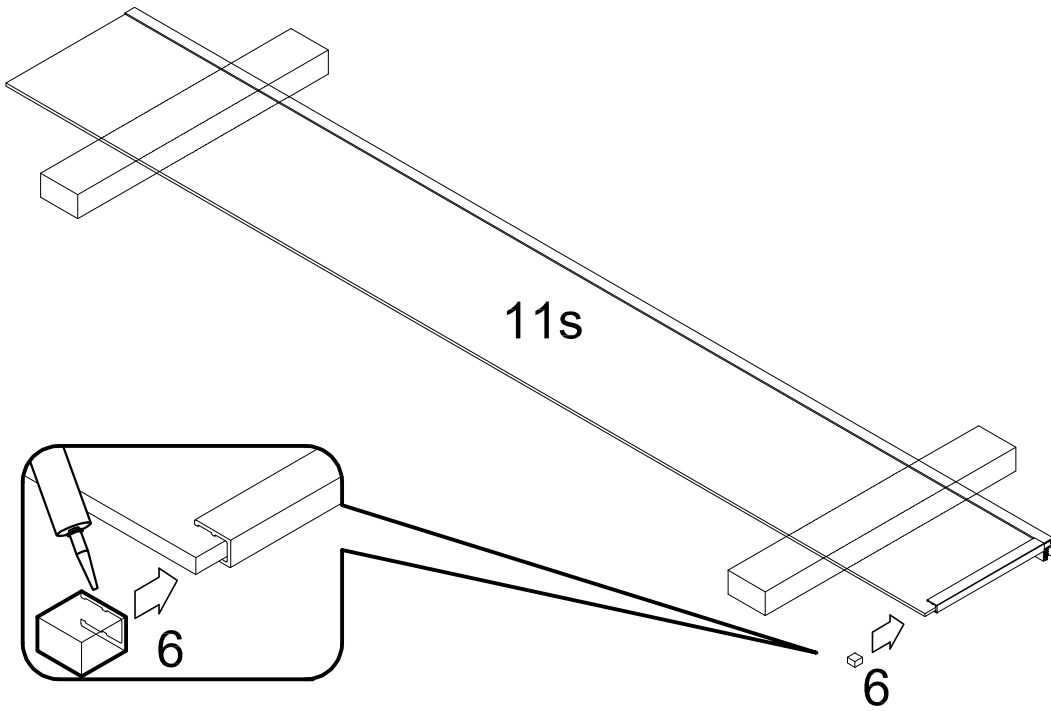

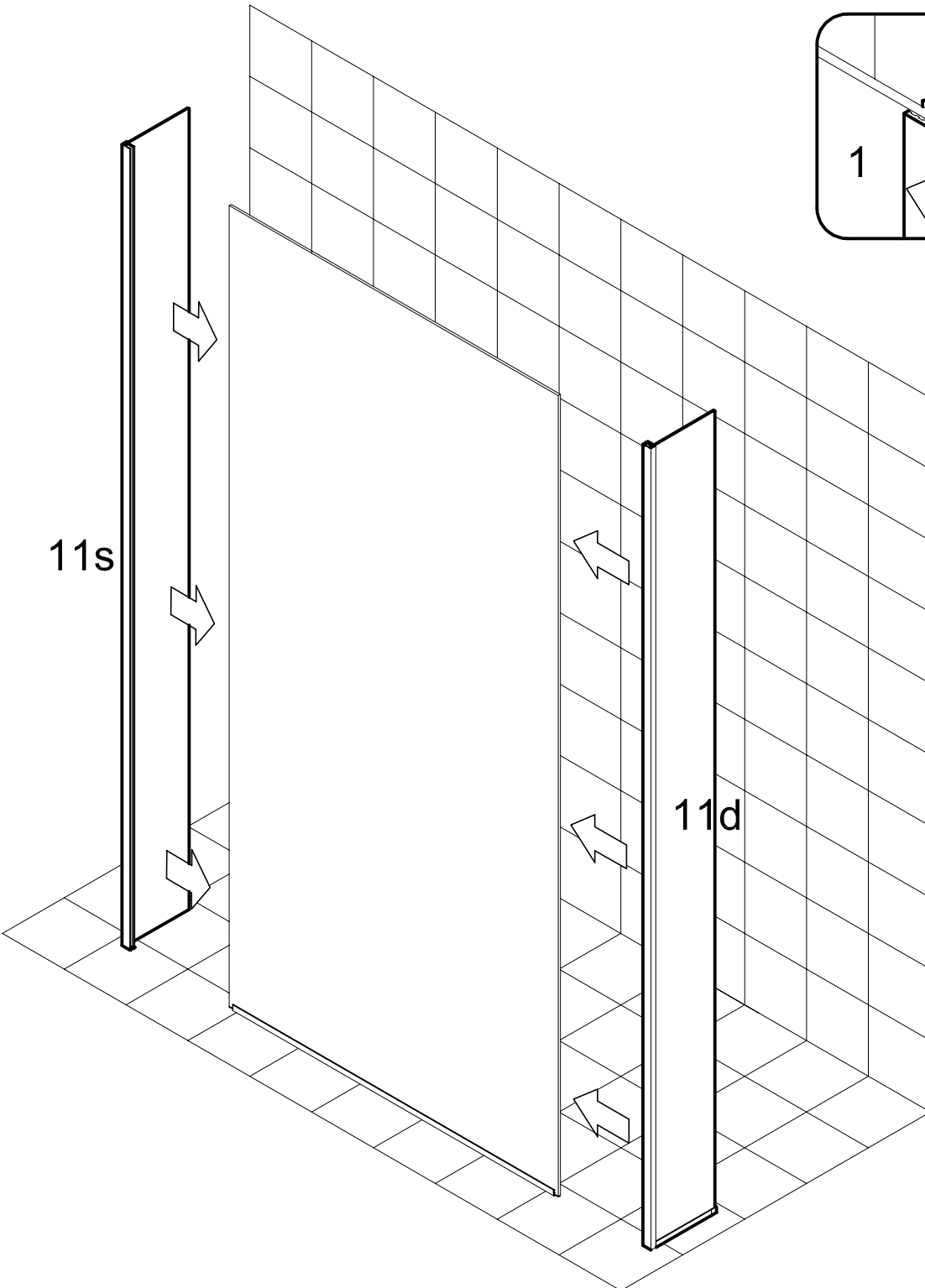
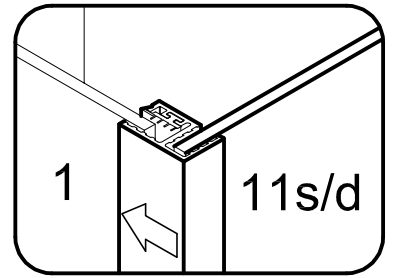
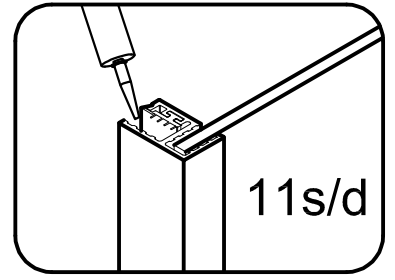

66

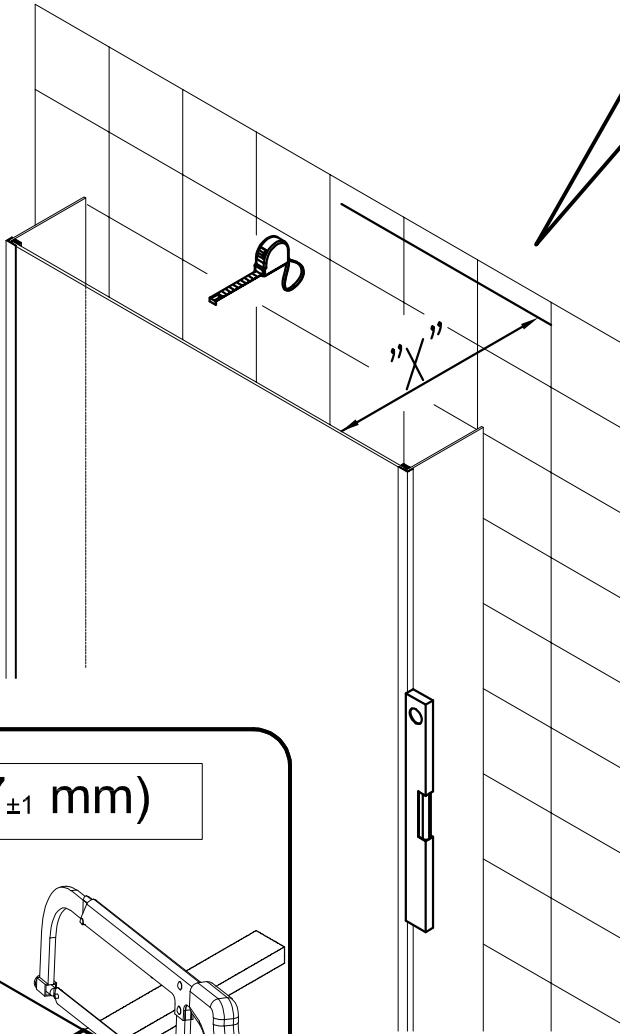

$$"Z" = (X - 17_{\pm 1} \text{ mm})$$

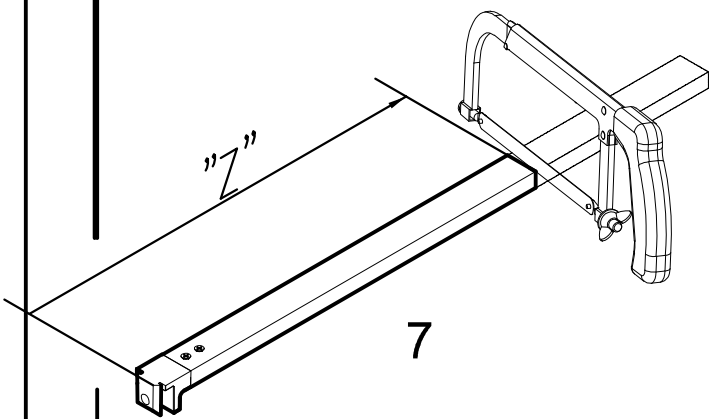

"X" max = 1200 mm

67

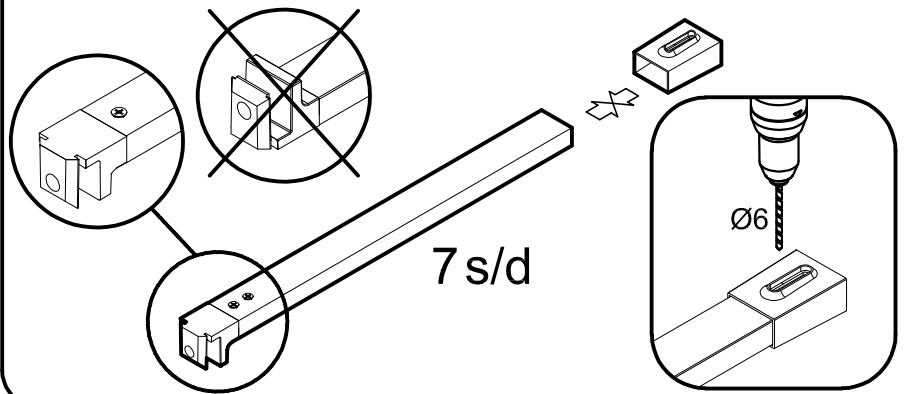
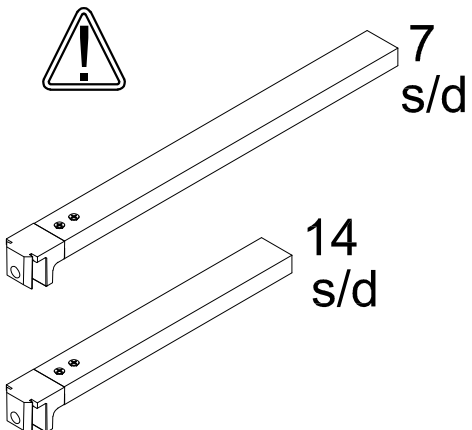

68

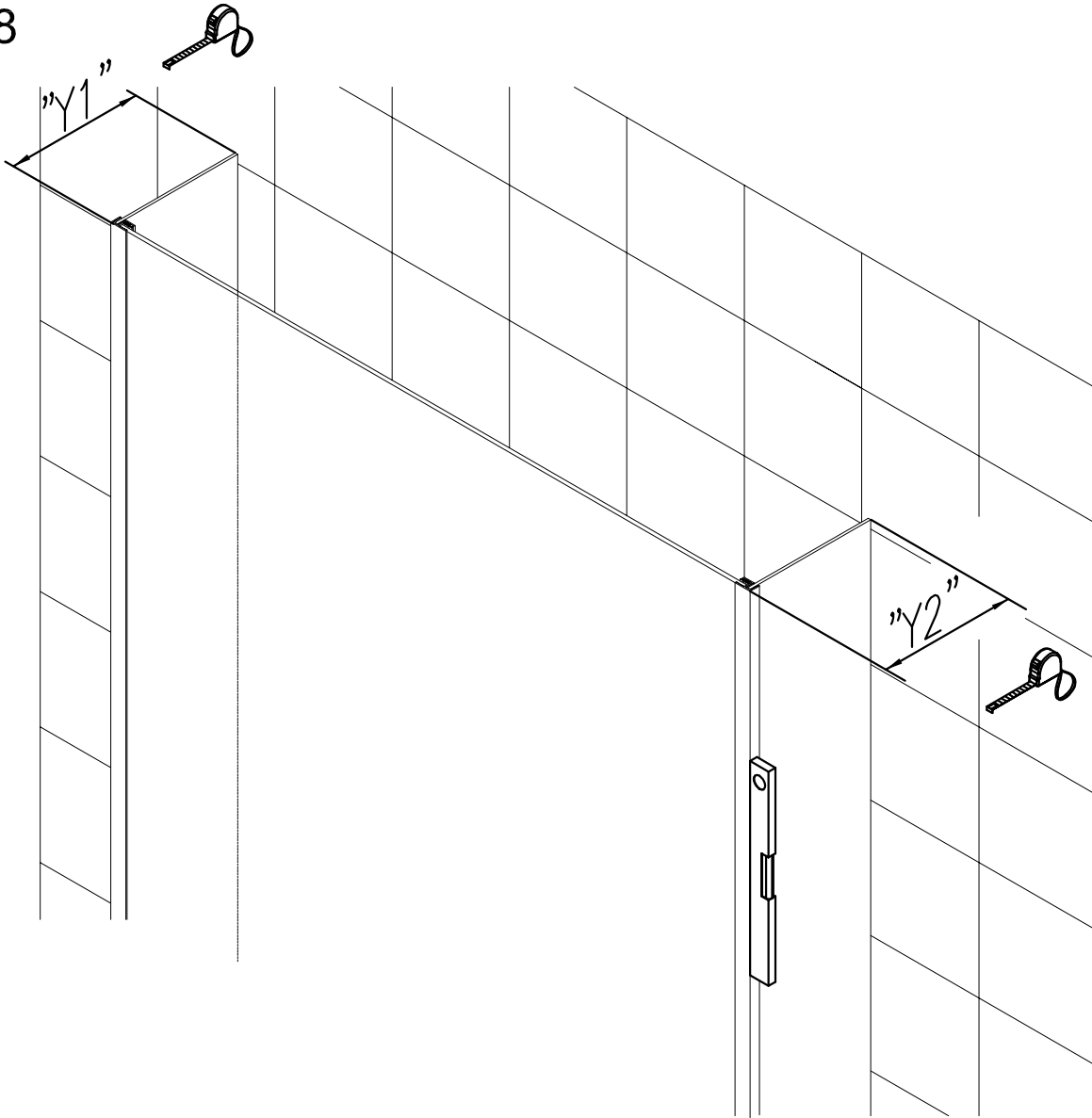

69

"H1" = (Y1 + 20 mm)

"H2" = (Y2 + 20 mm)

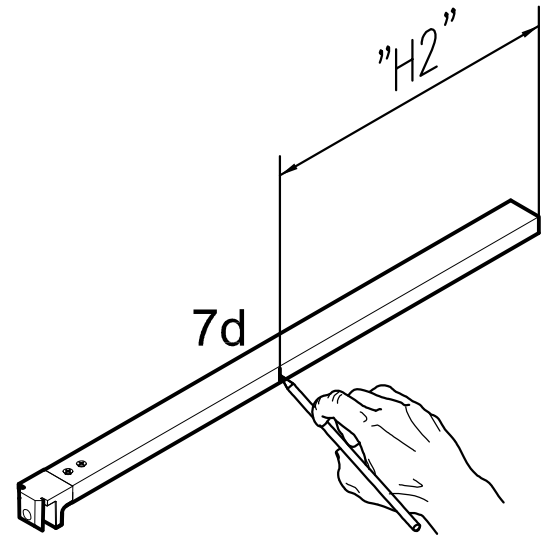
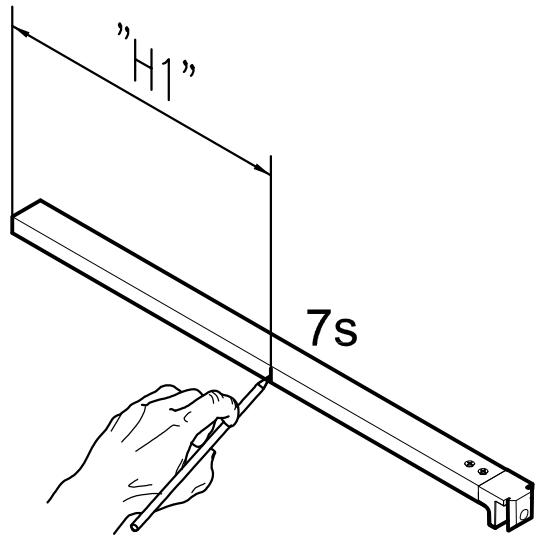

70

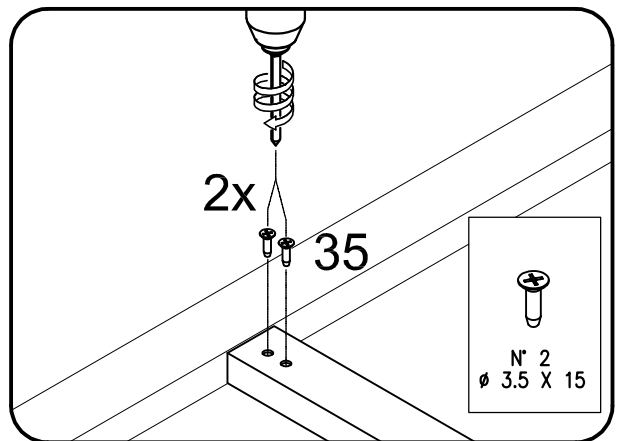
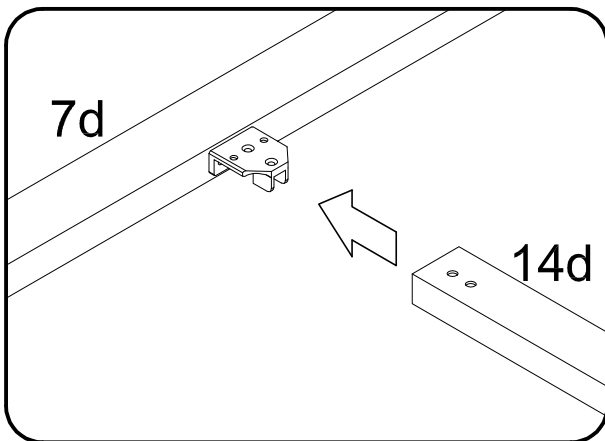
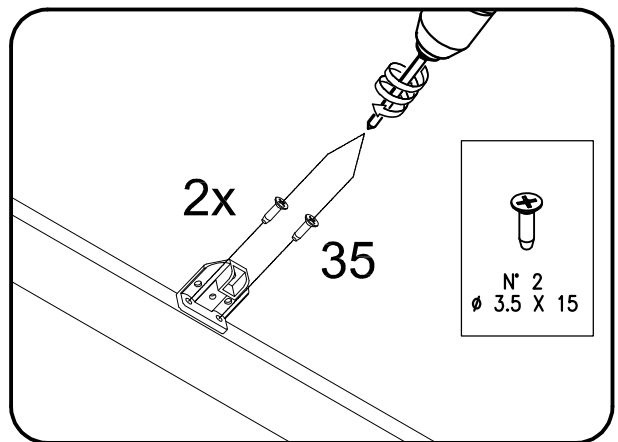
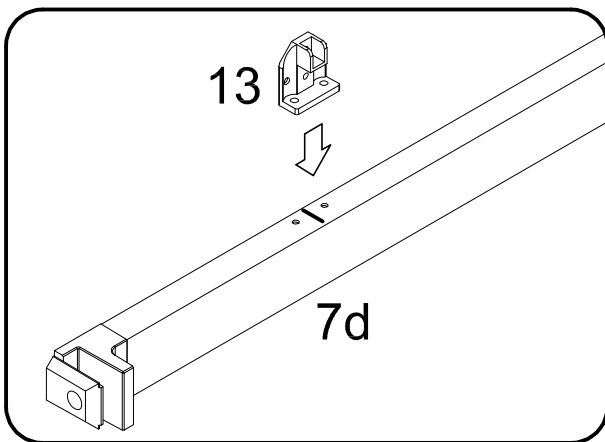
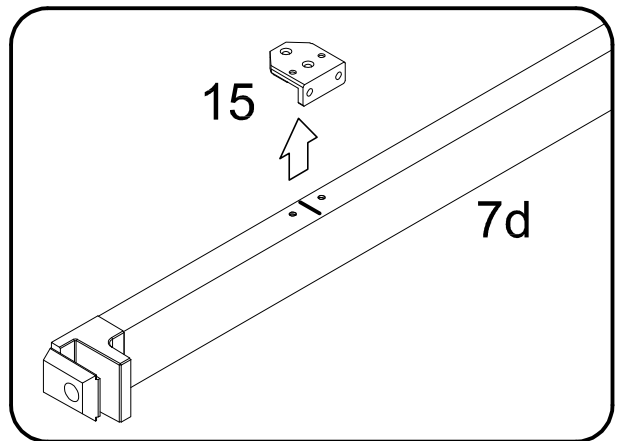
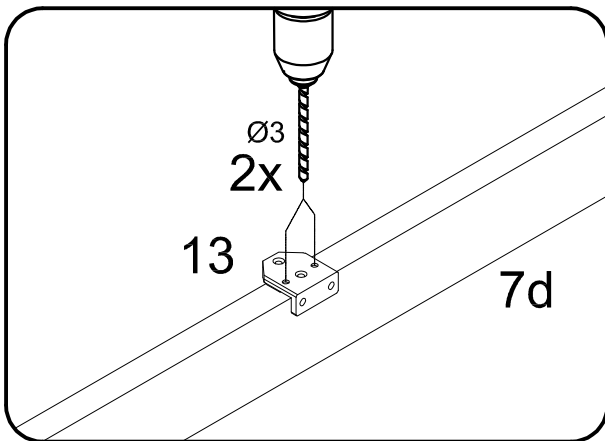
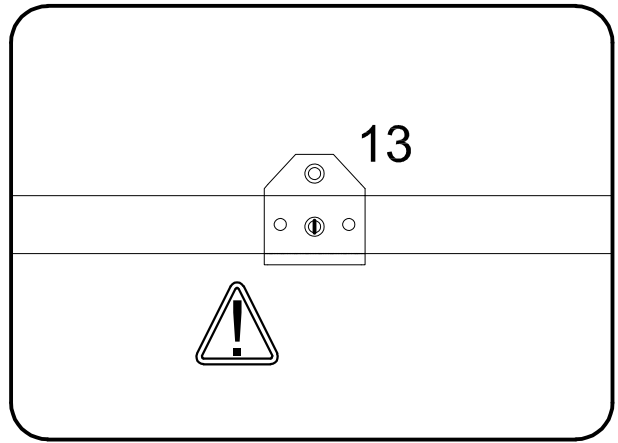
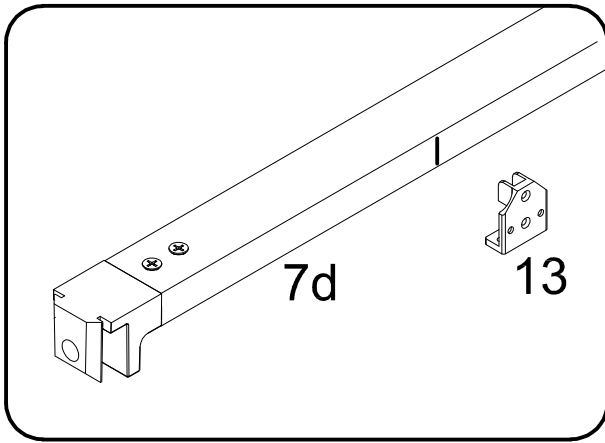

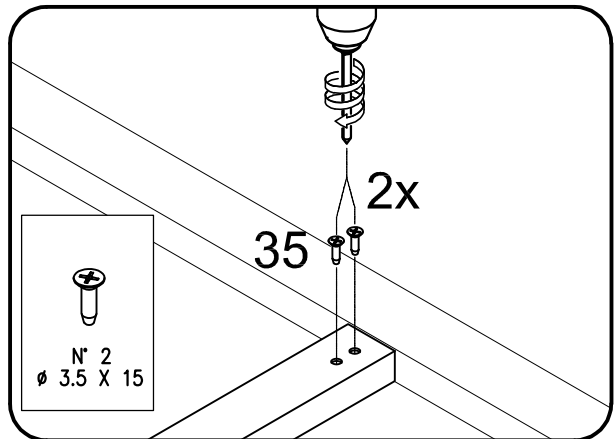
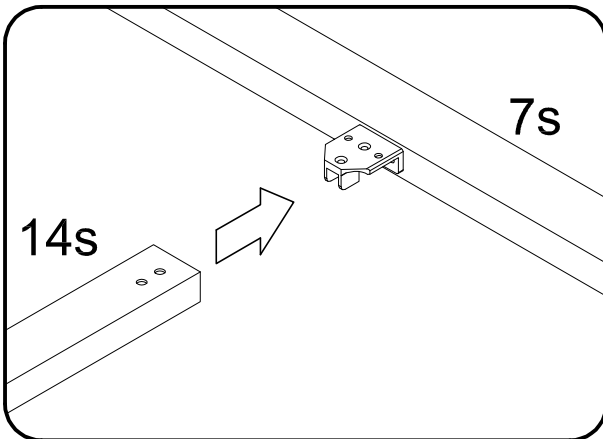
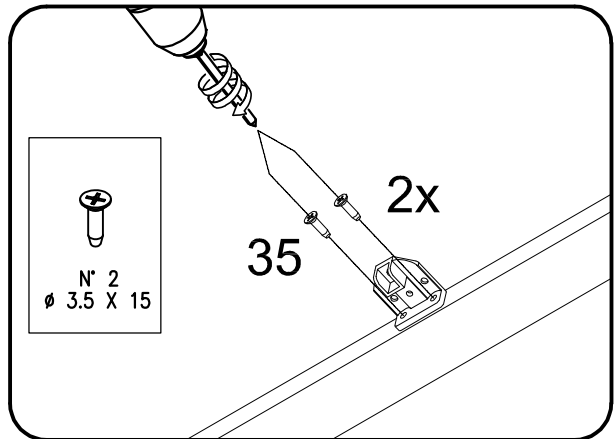
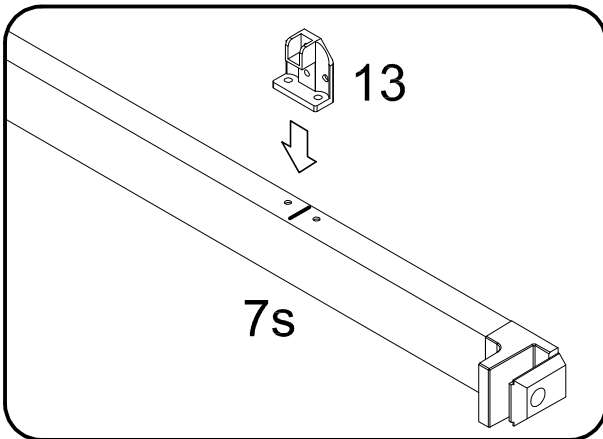
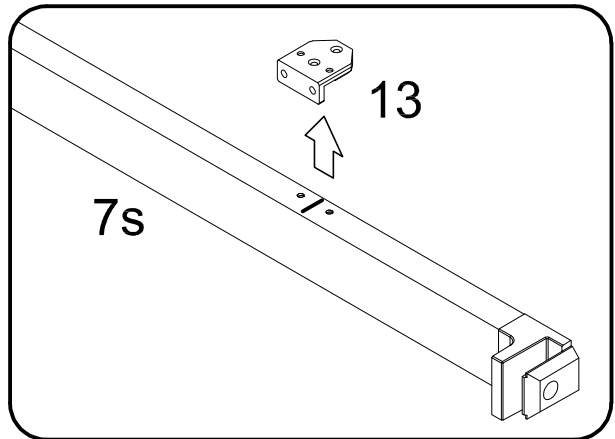
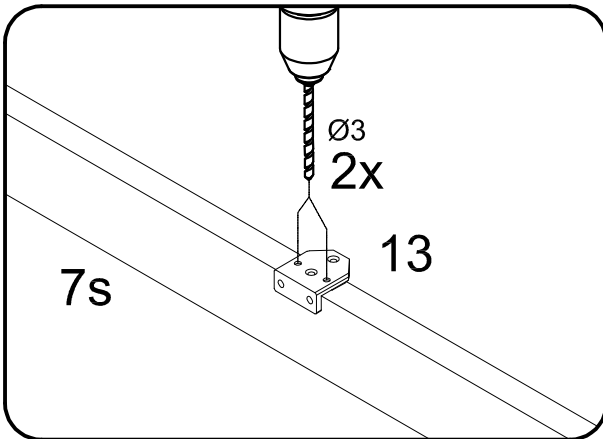
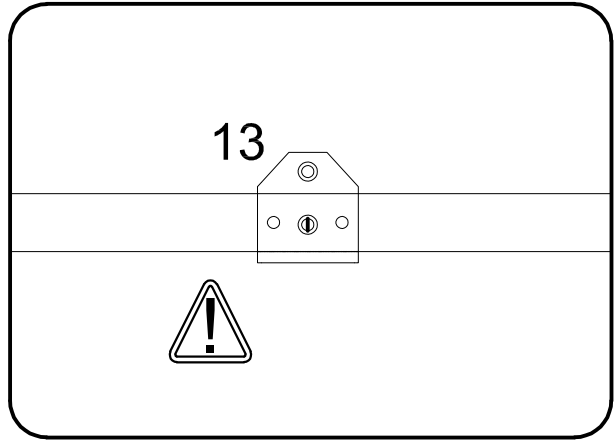
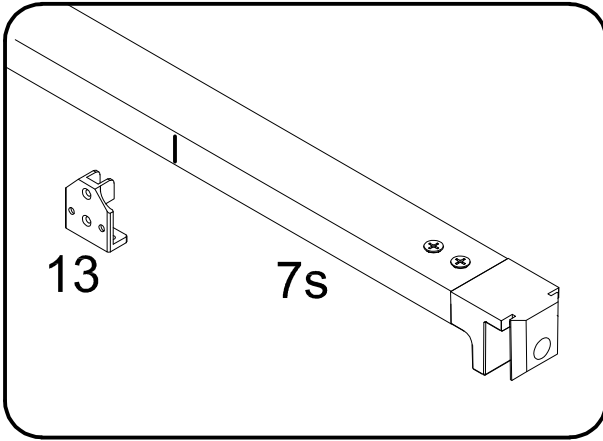

72

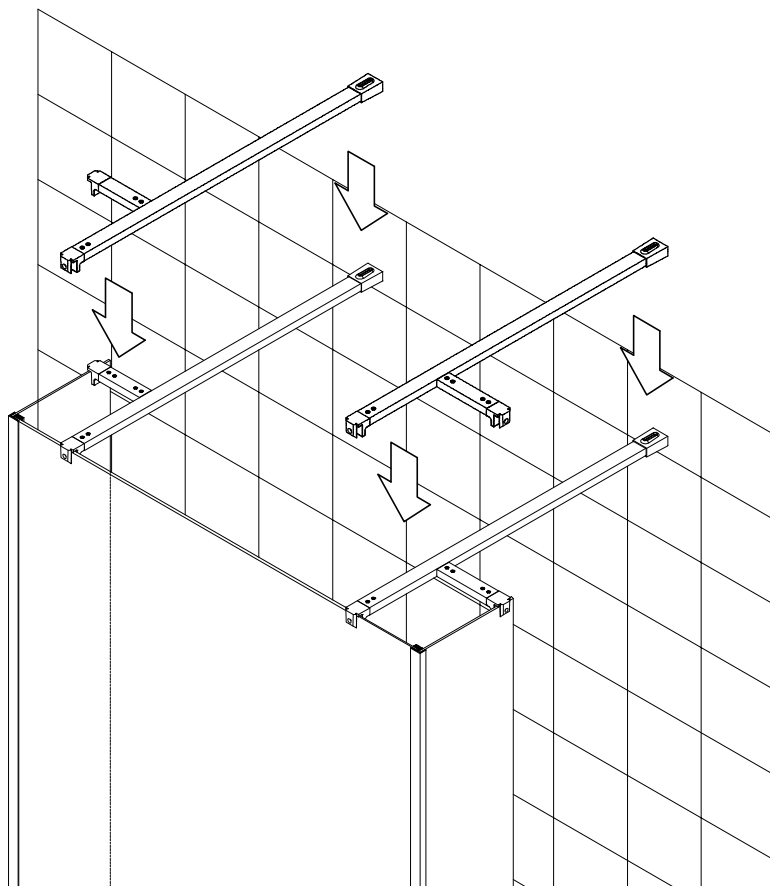

73

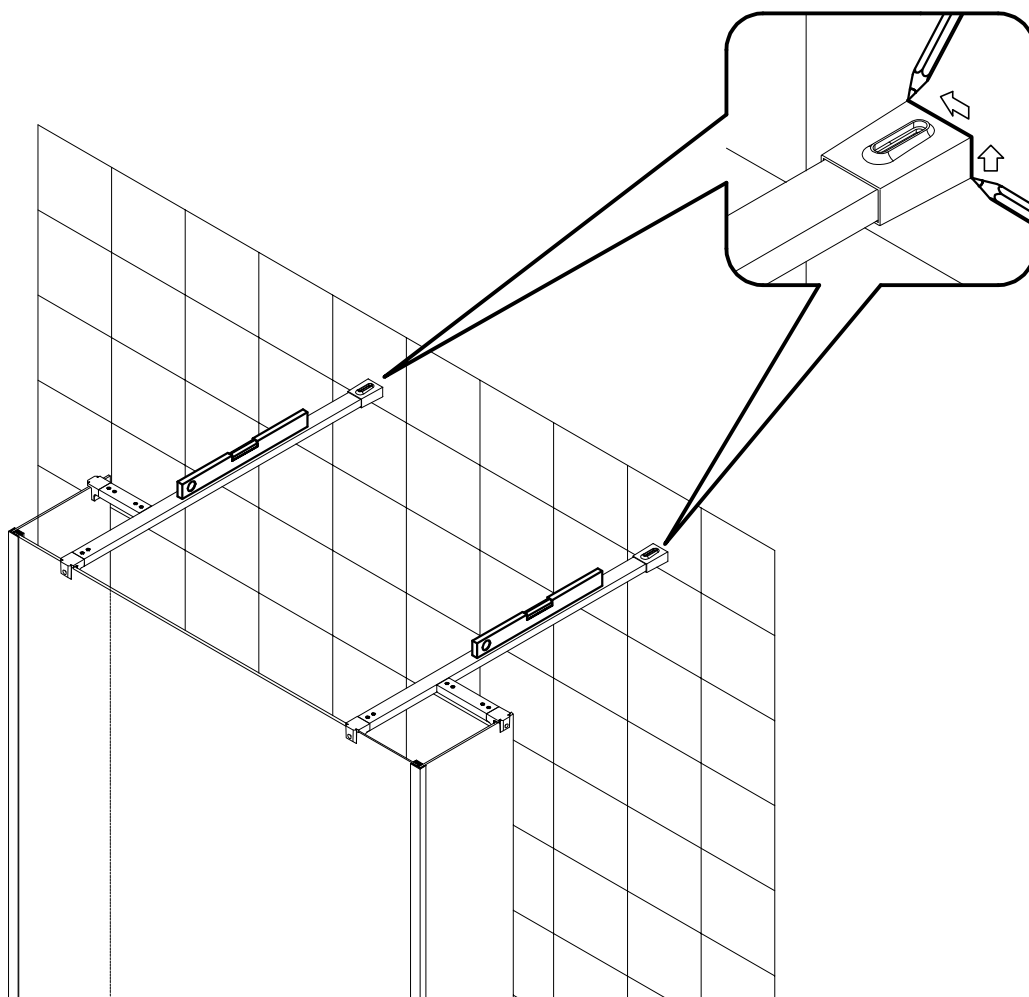

74

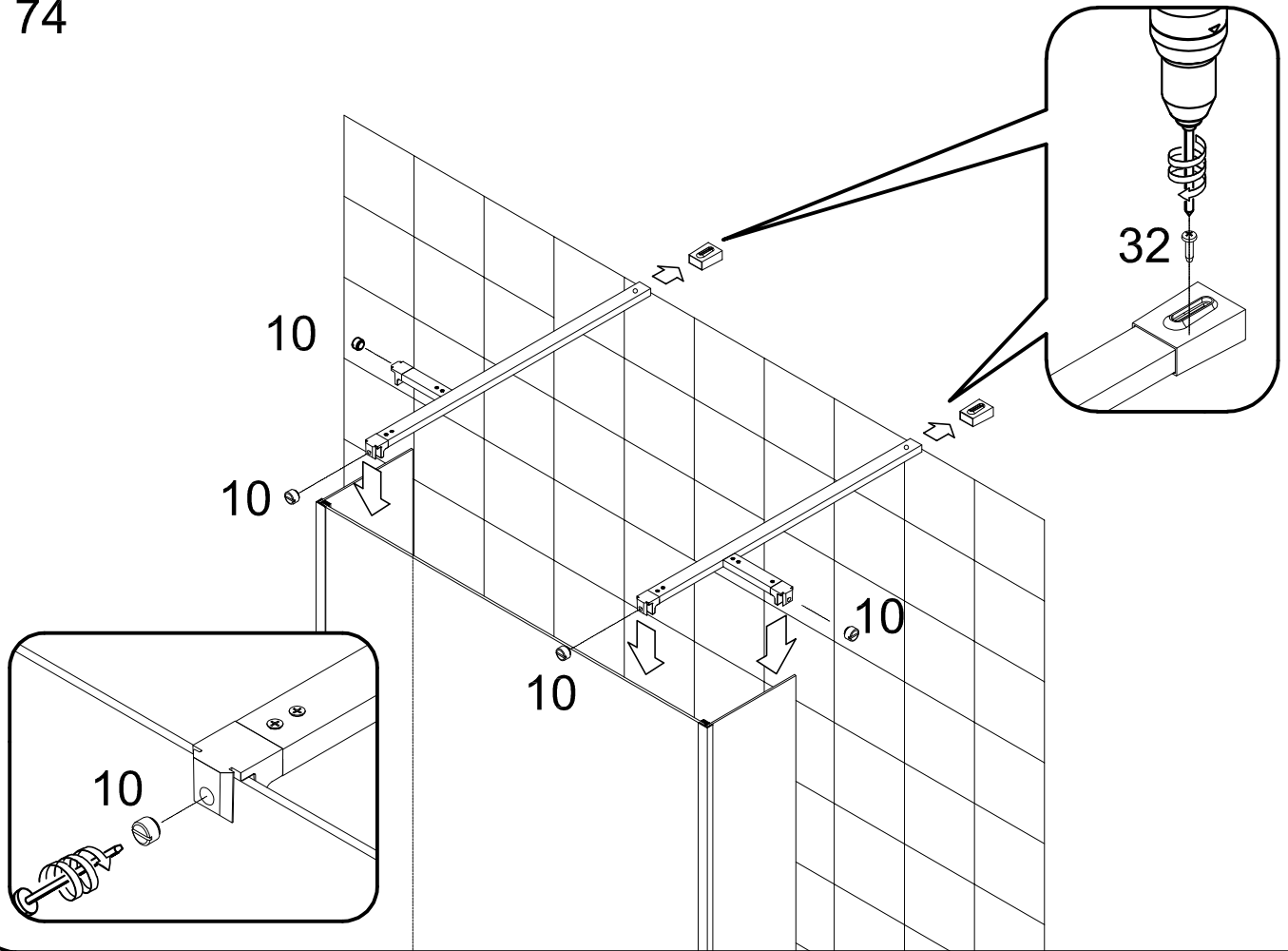

75

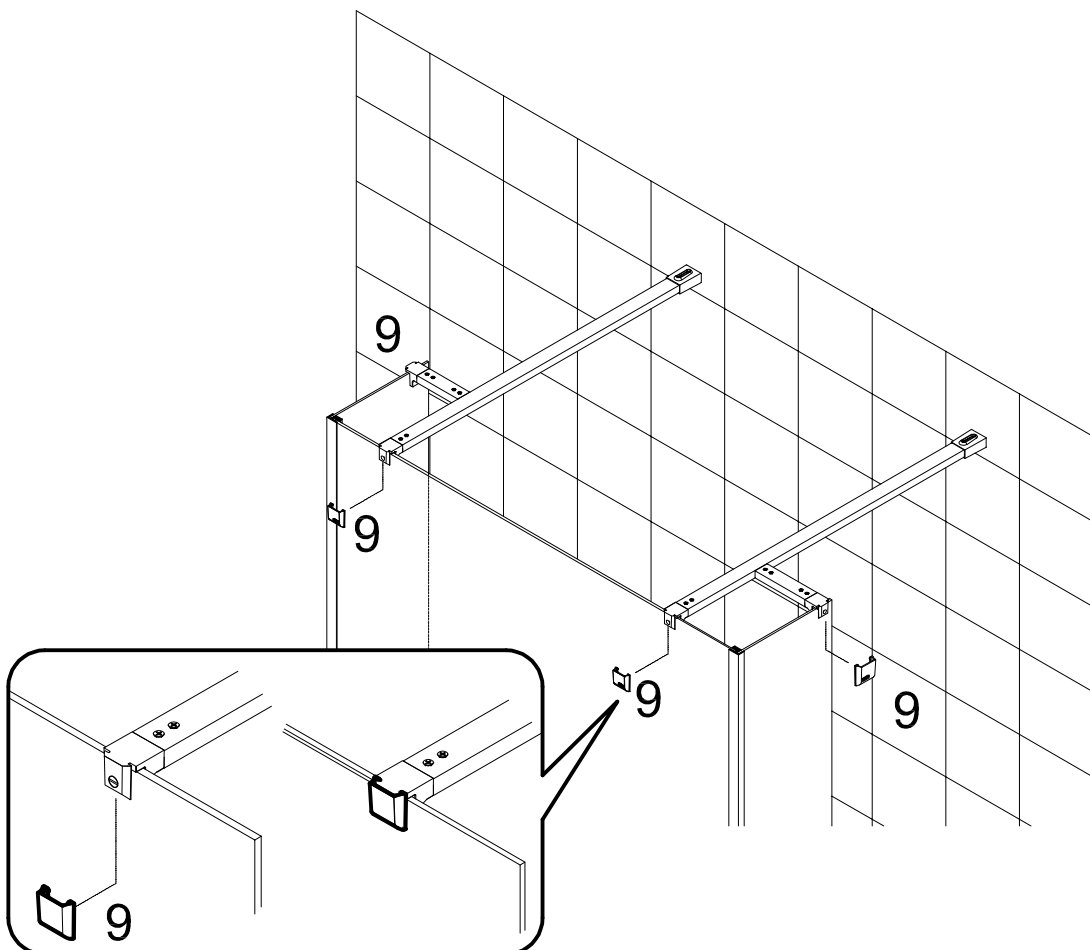



Pag. 1

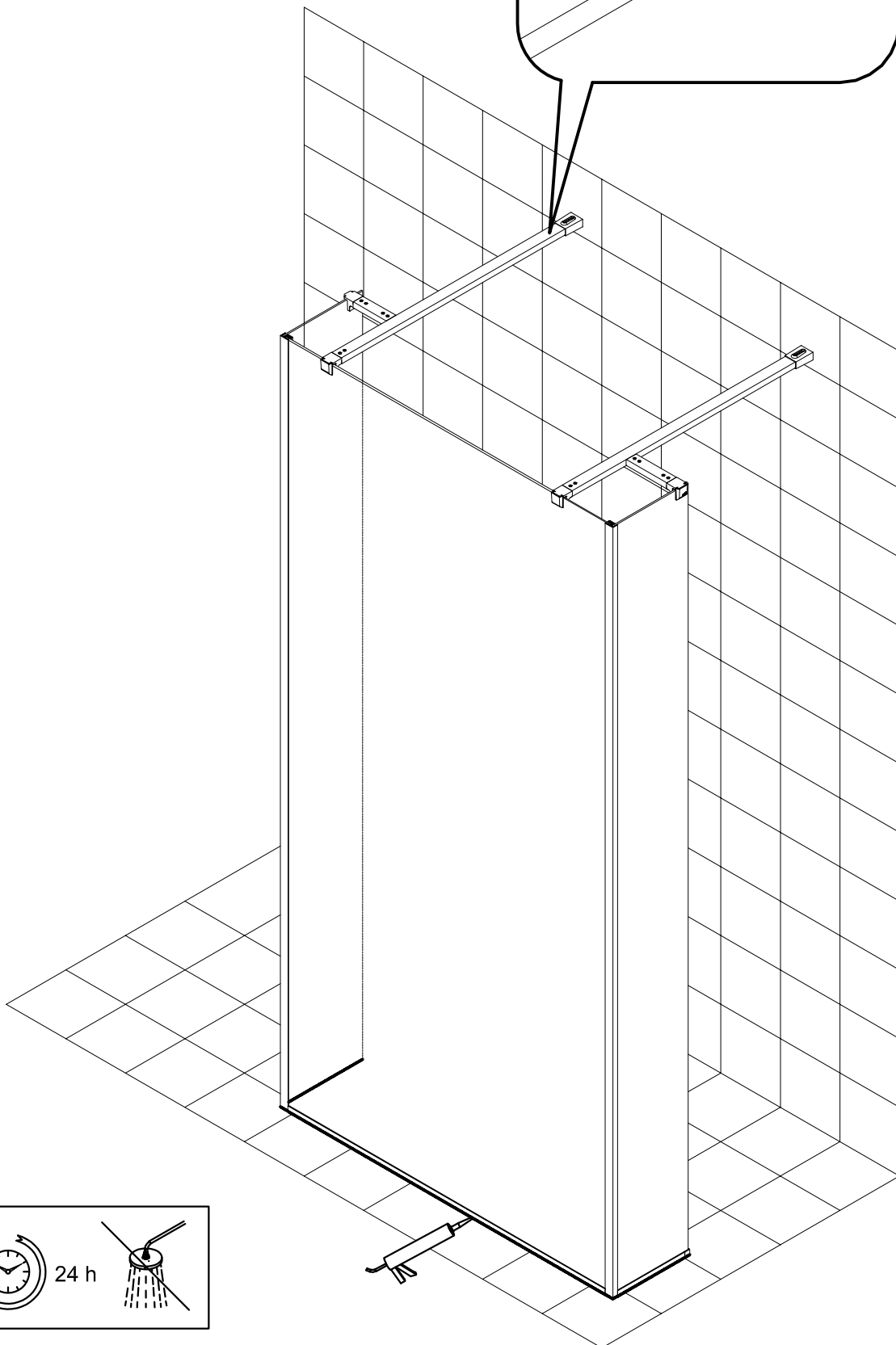
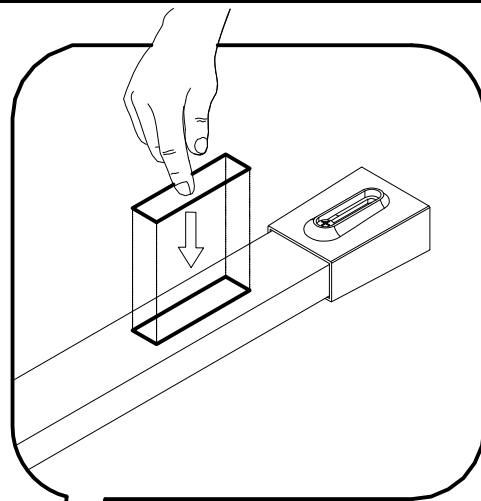
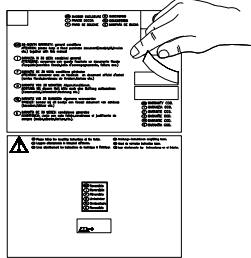

24 h



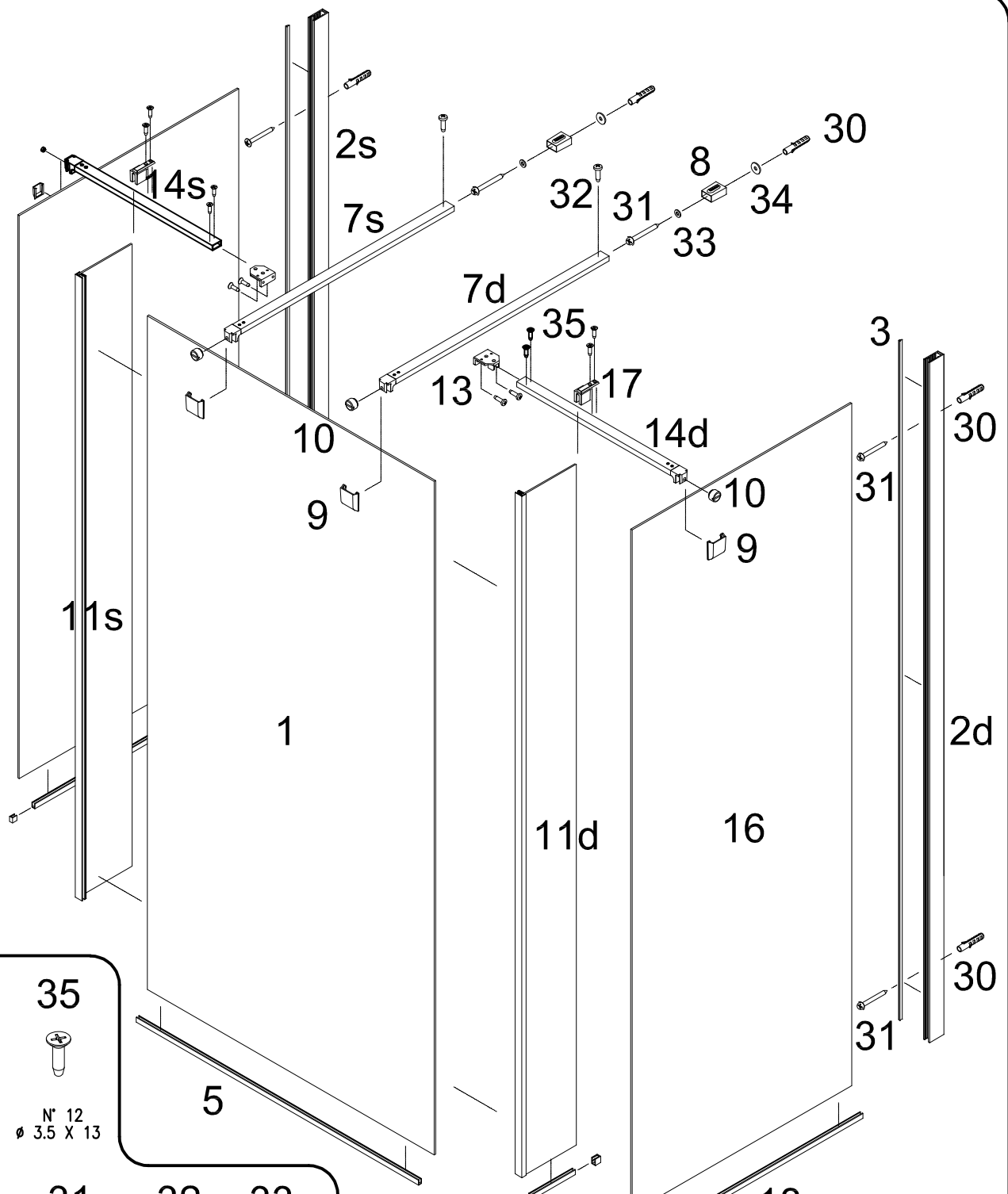

- | | | | |
|-----------------------------------|--------------------------------------|-------------------------------------|-----------------------|
| 34

N° 2 | 35

N° 12
Ø 3.5 X 13 | | |
| 30

N° 2
Ø 6 X 30 | 31

N° 2
Ø 4,2 X 32 | 32

N° 2
Ø 3.5 X 13 | 33

N° 2 |

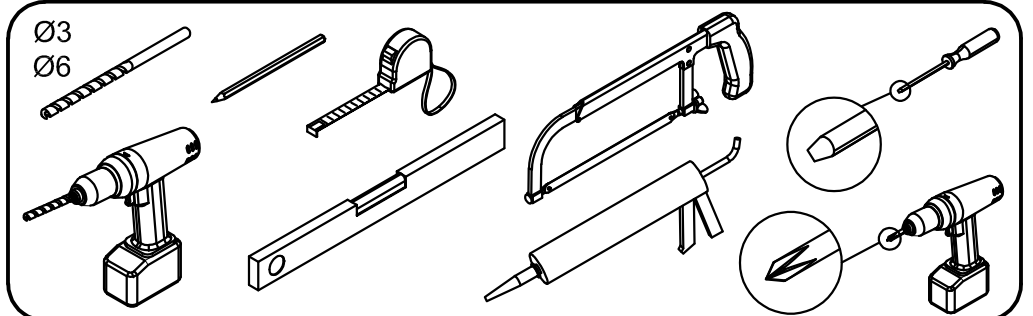
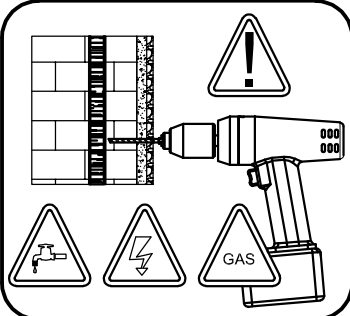

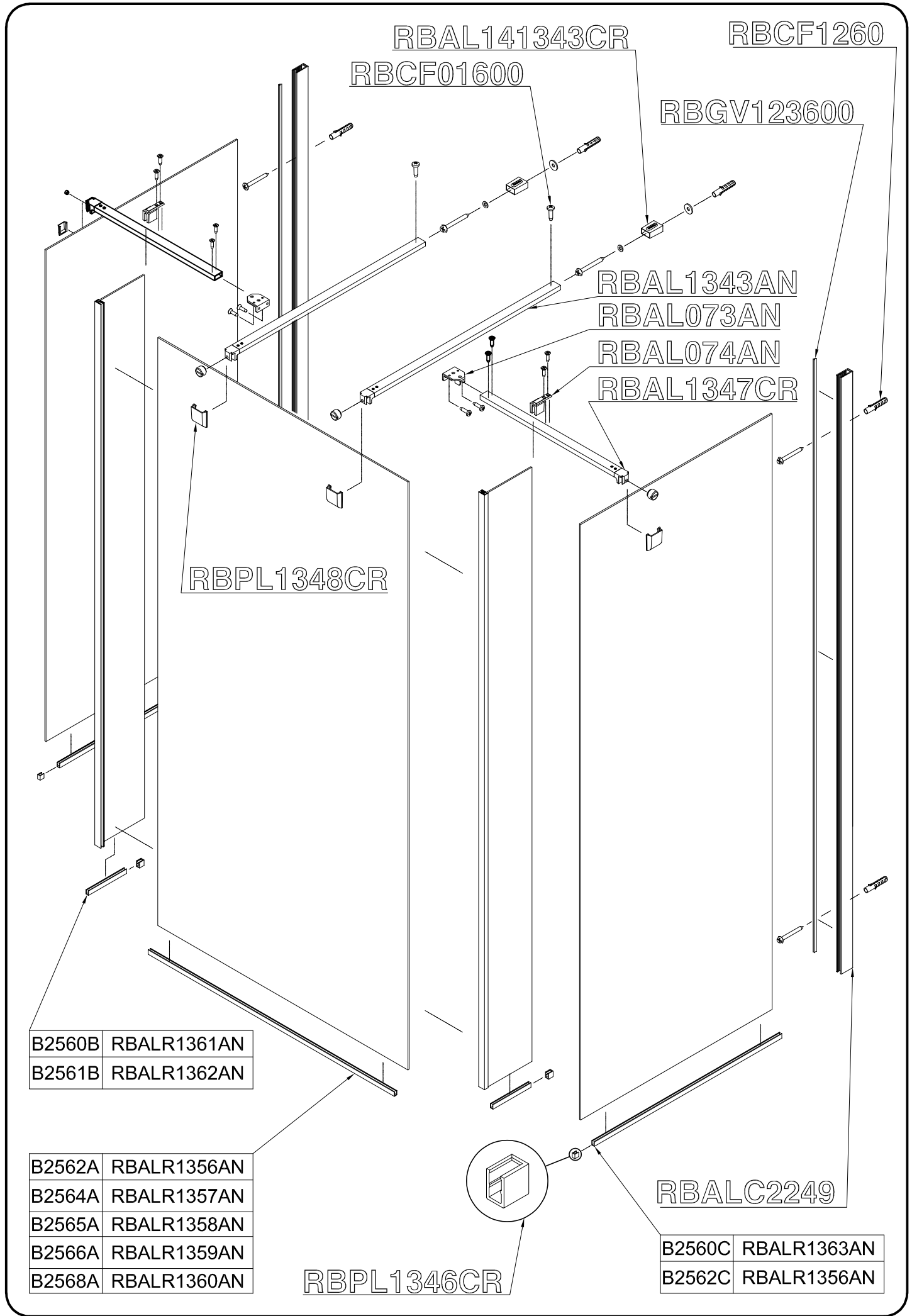

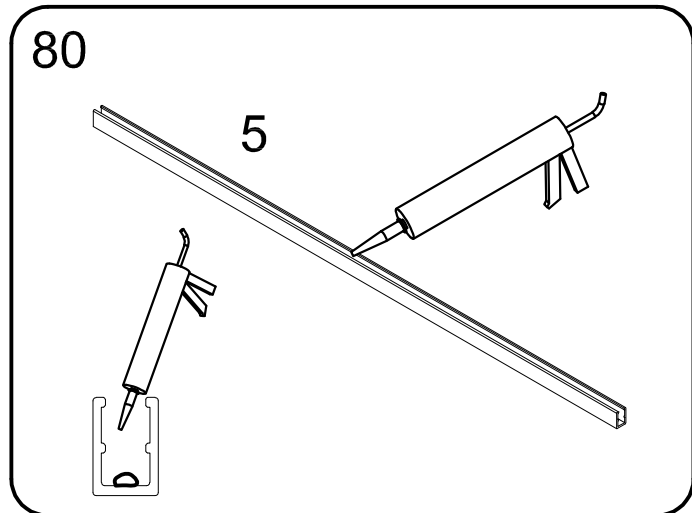
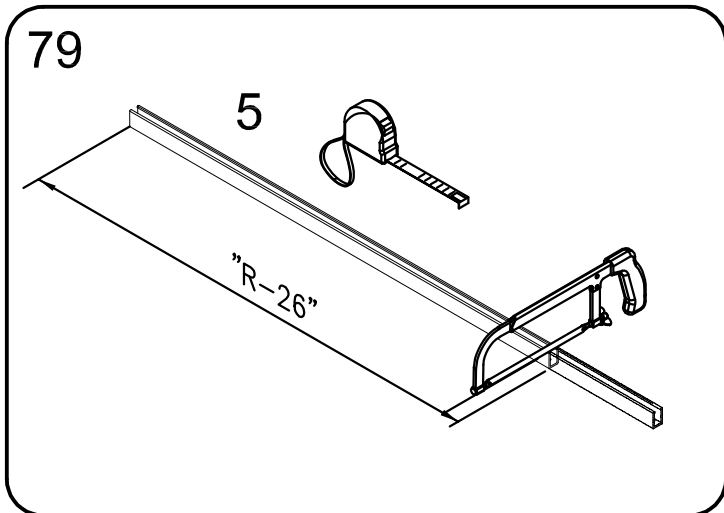
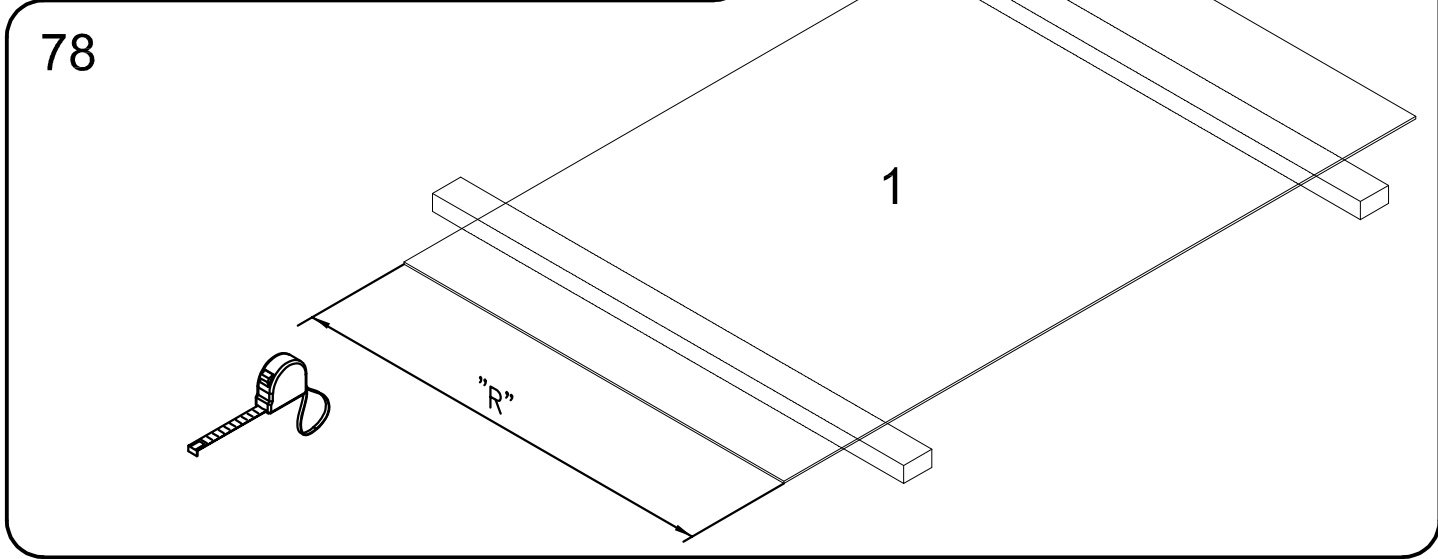
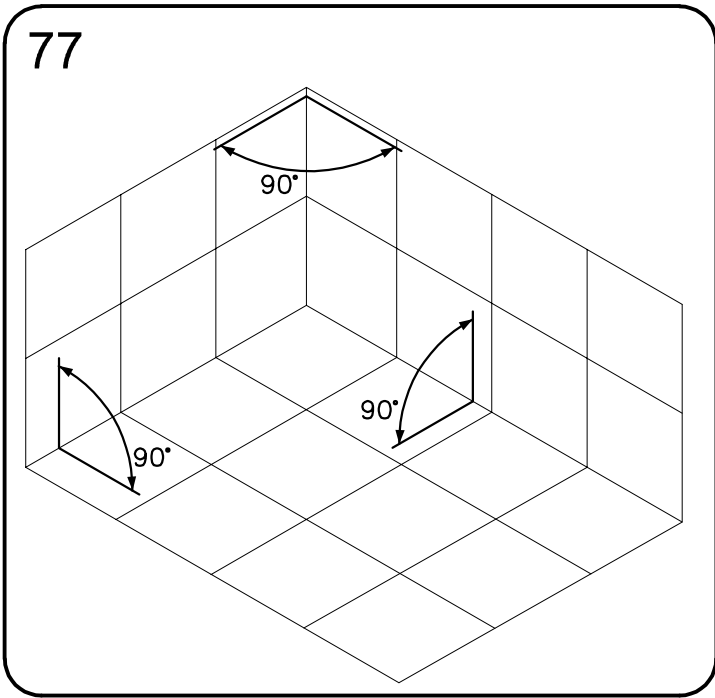
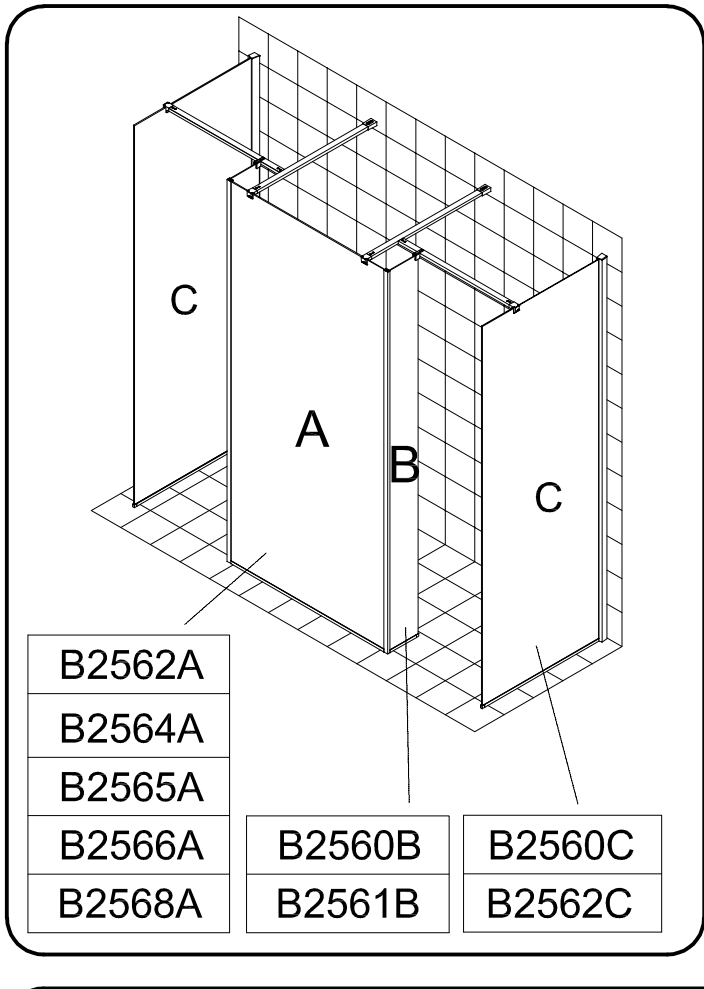

81

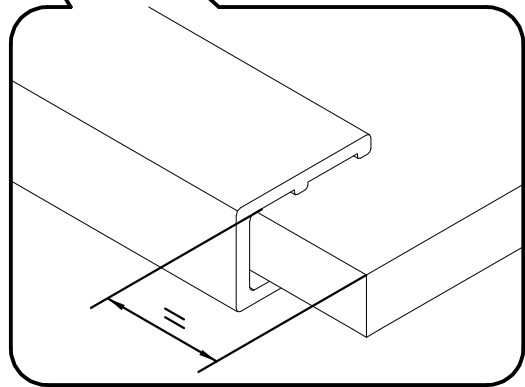
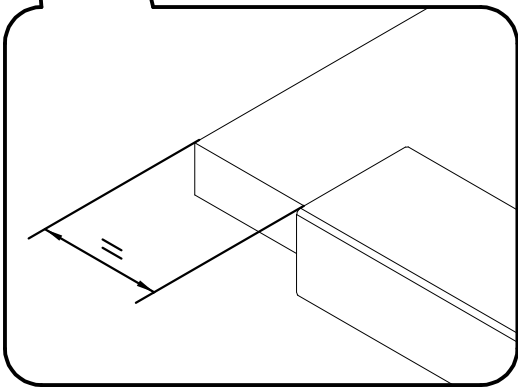
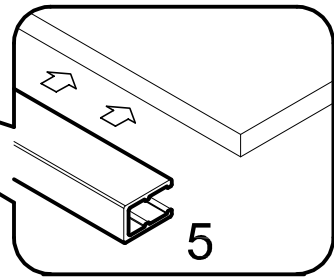
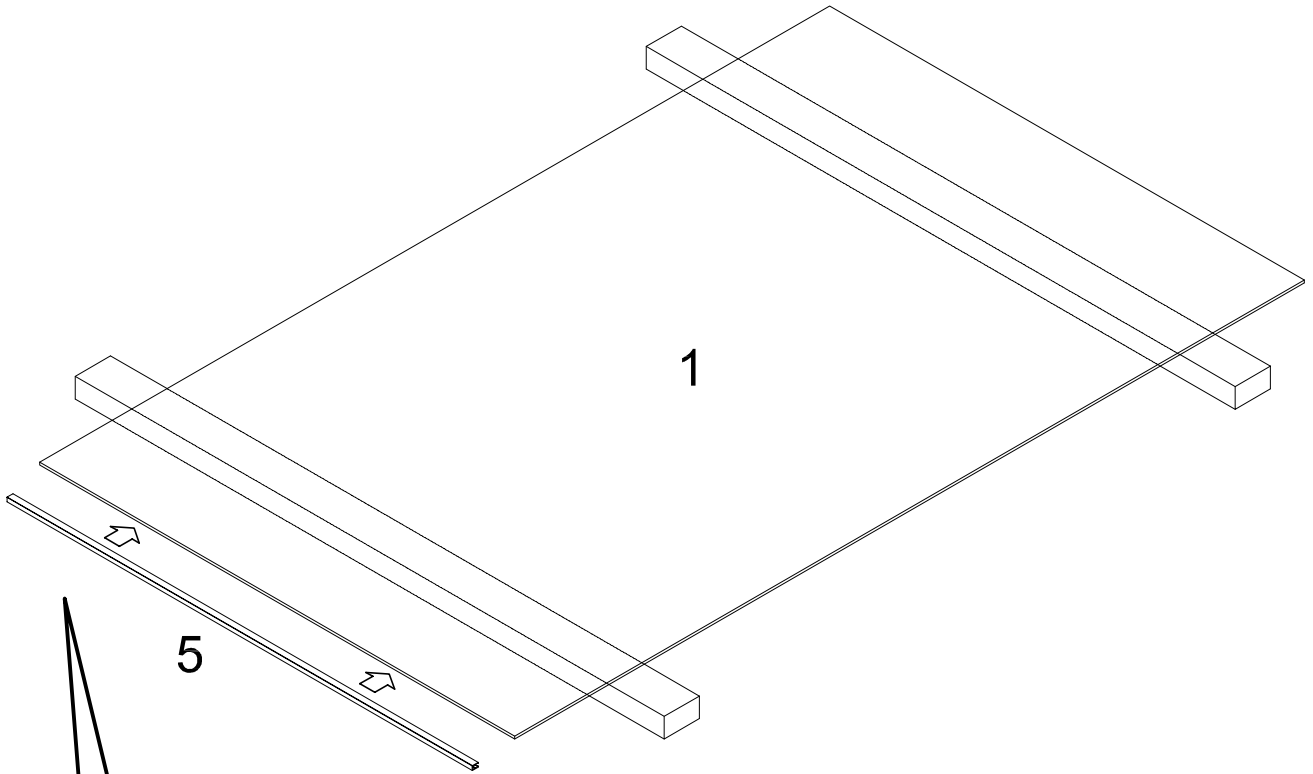

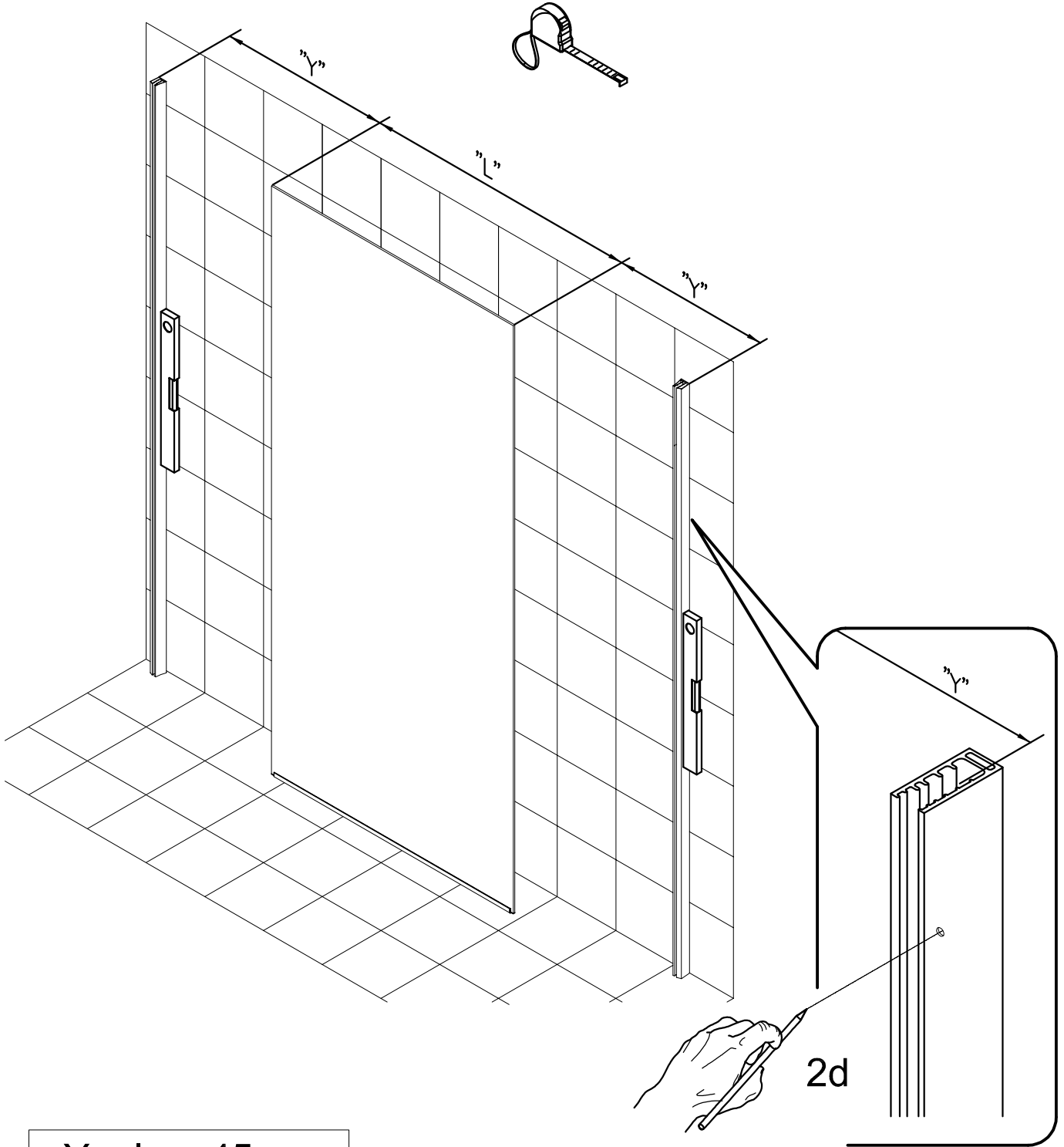

Y min = 45 cm
Y max = 65 cm

83

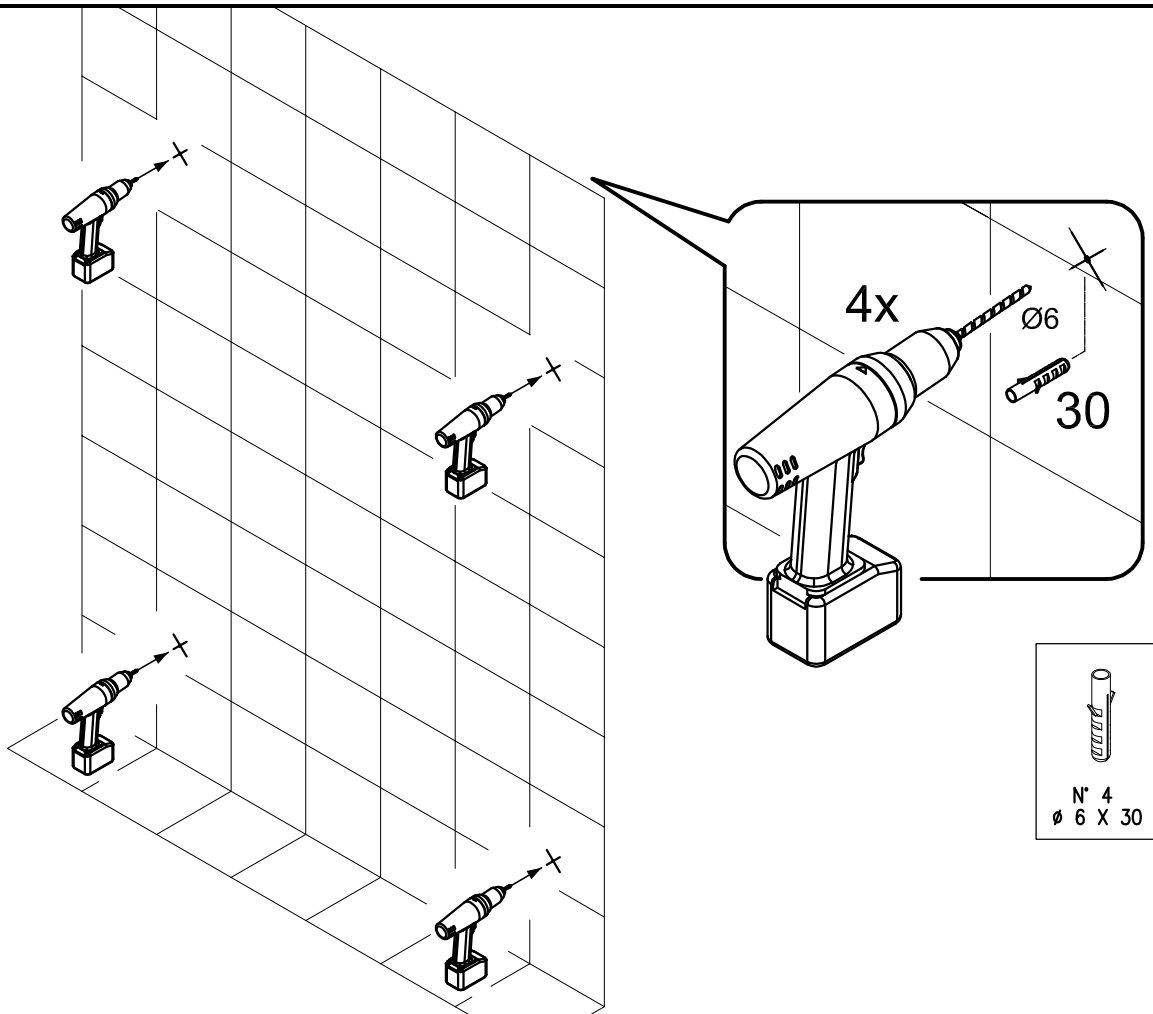

84

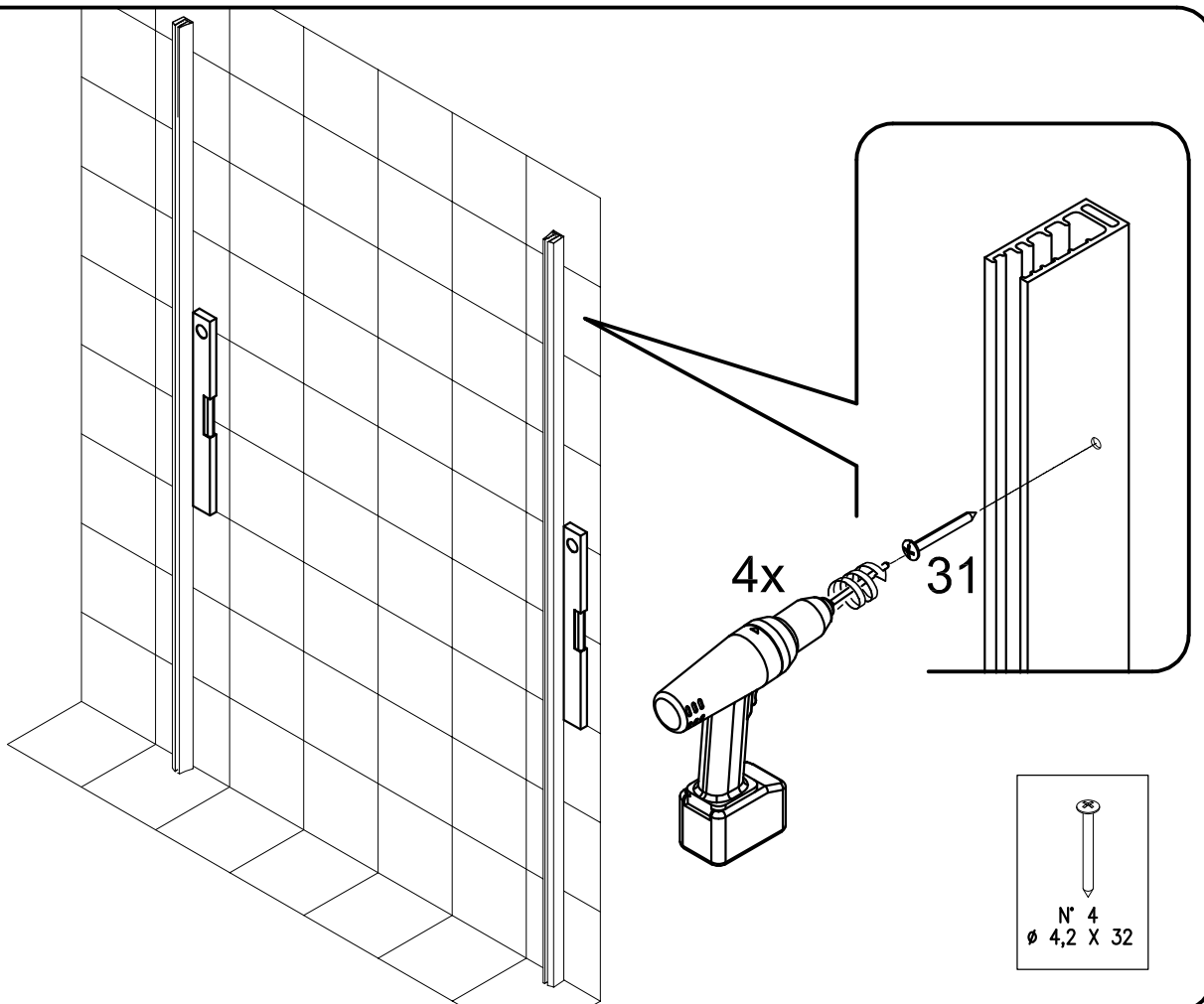

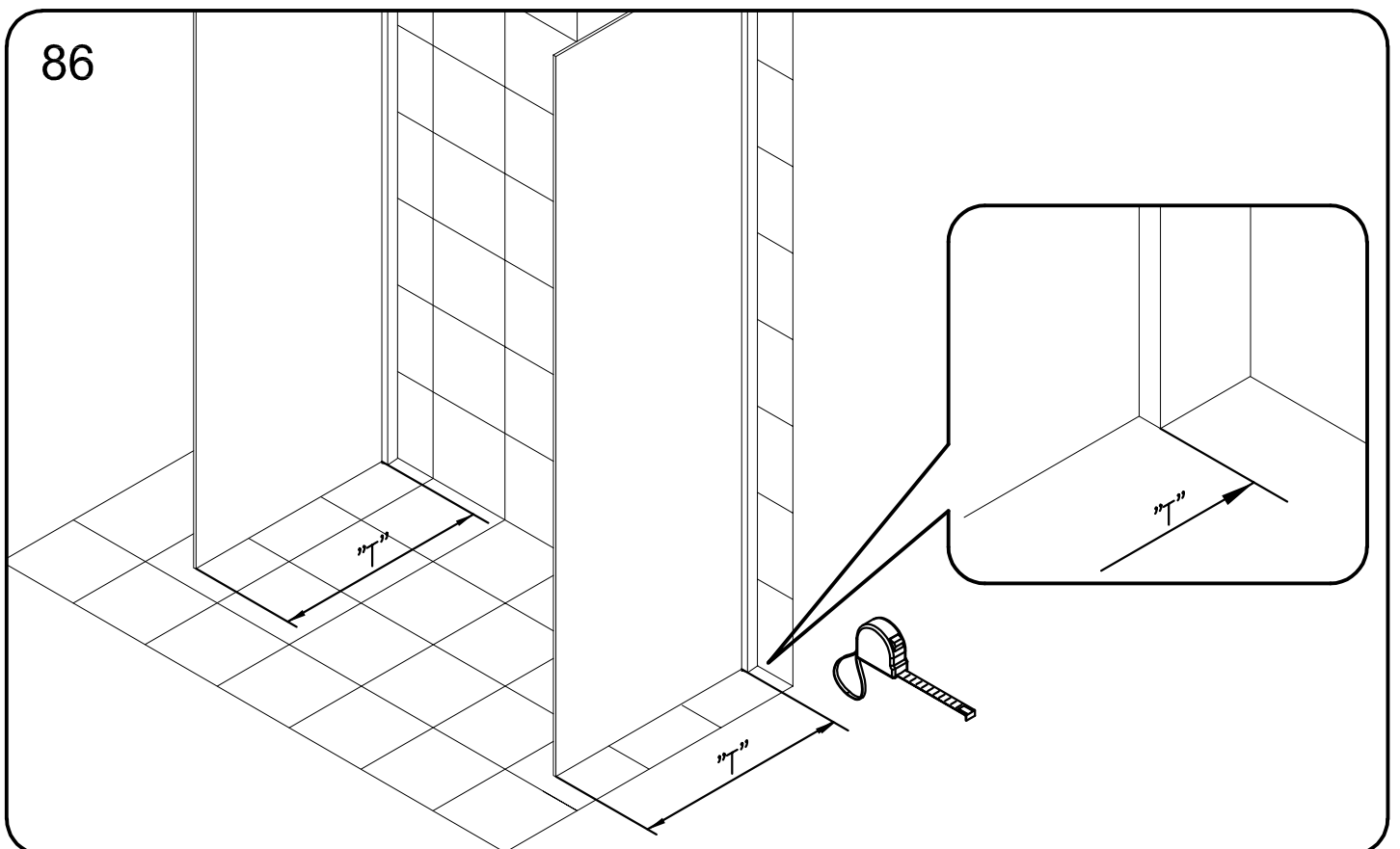
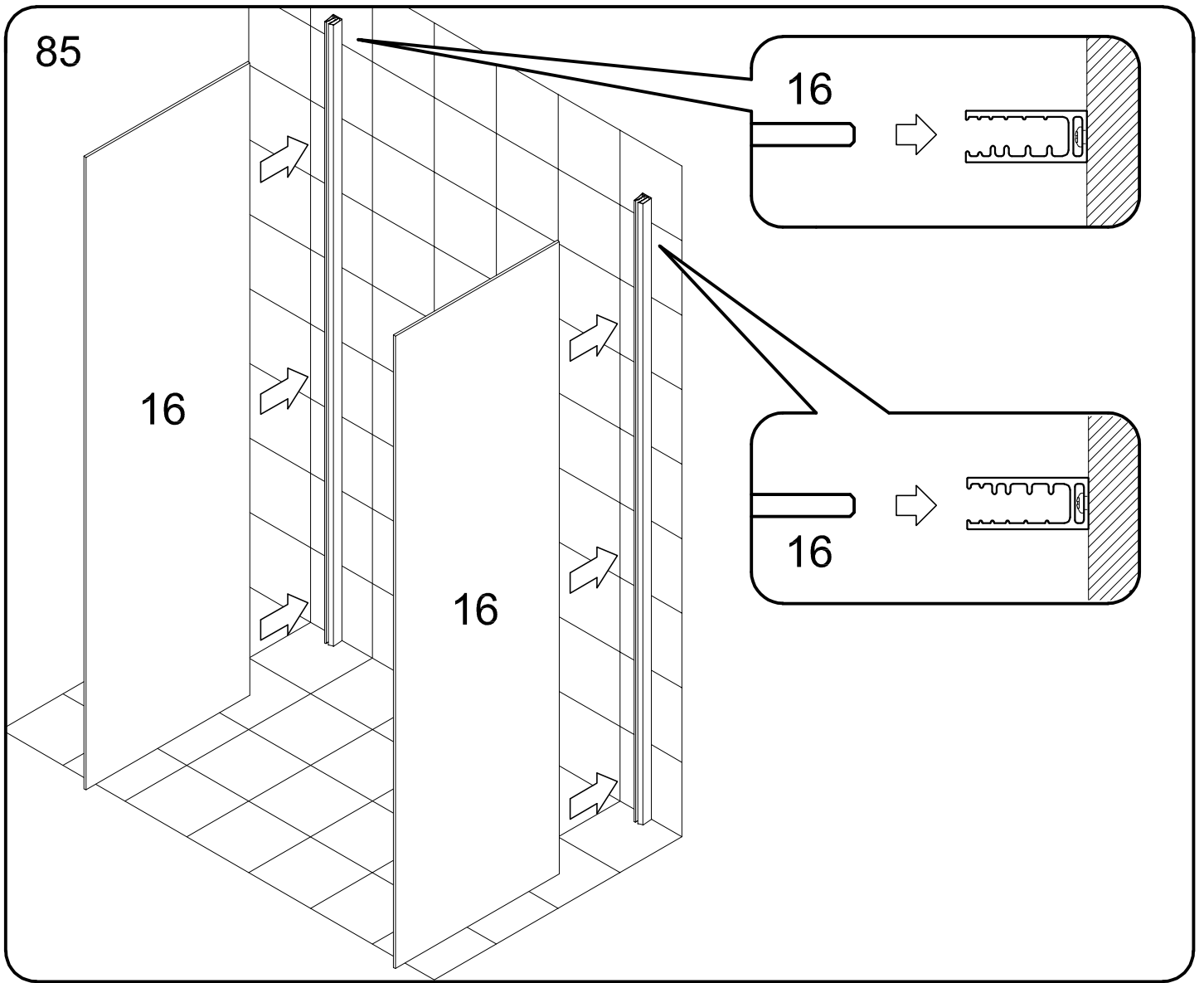

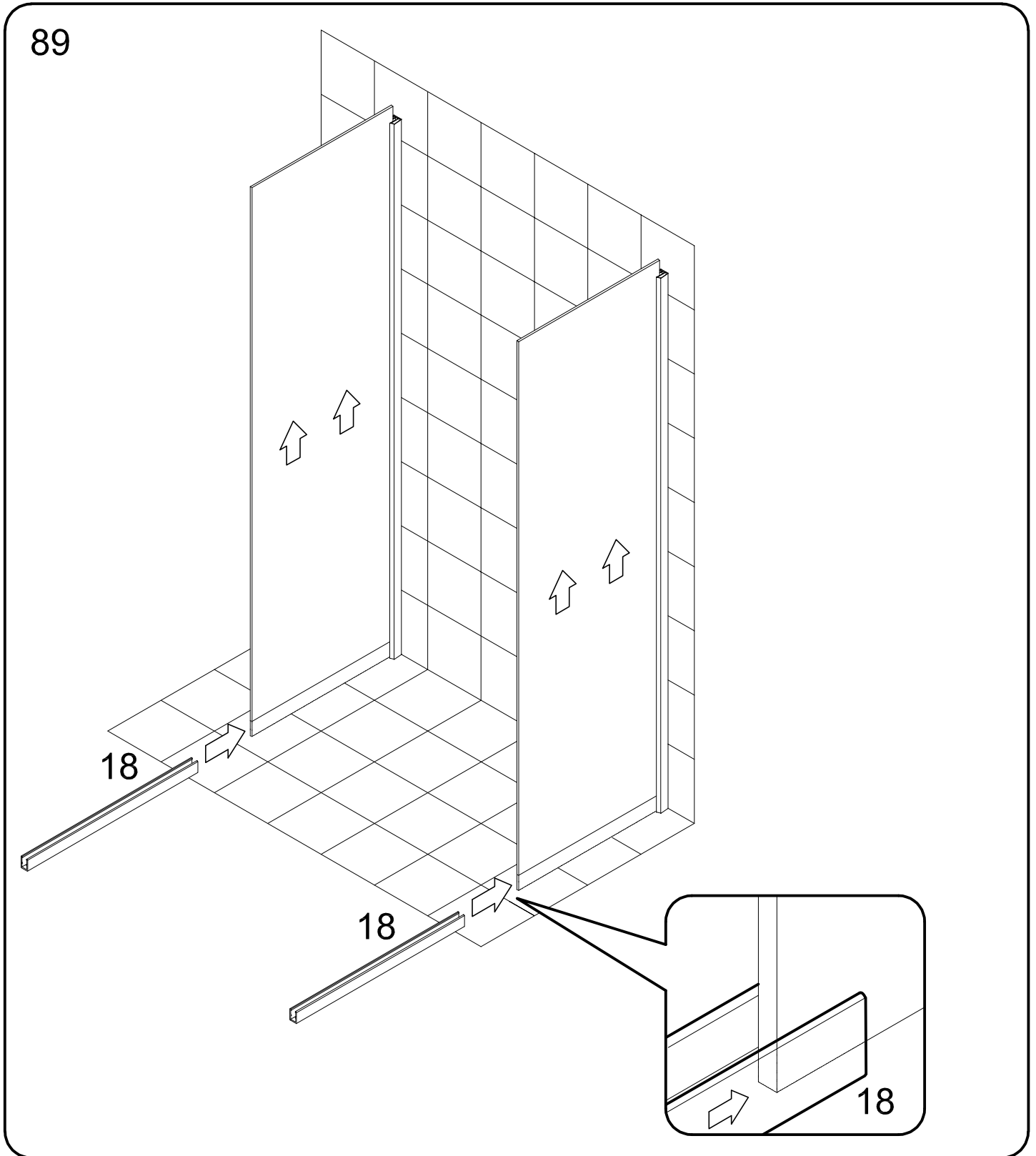
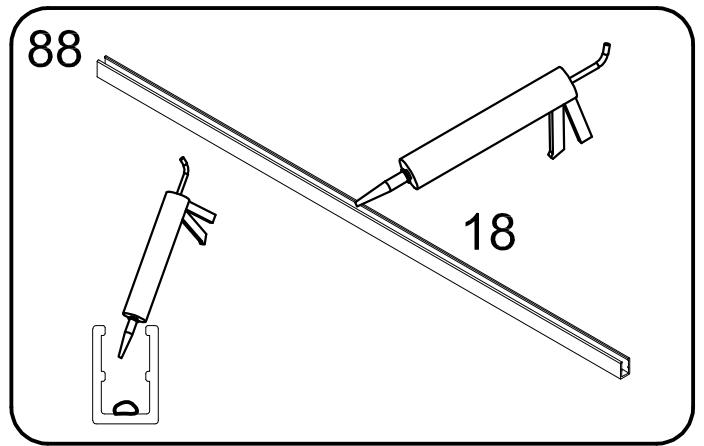
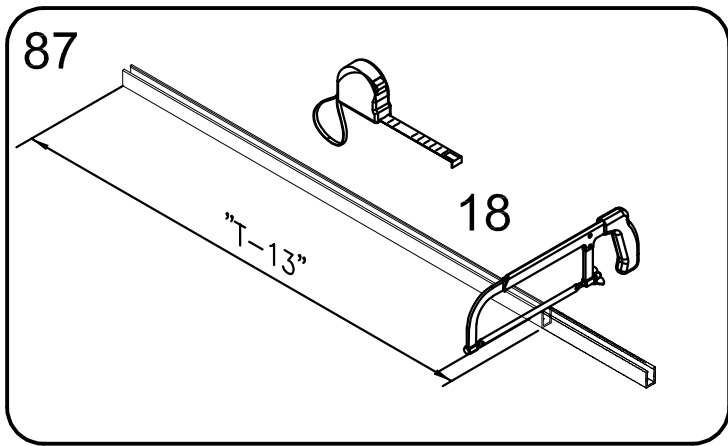

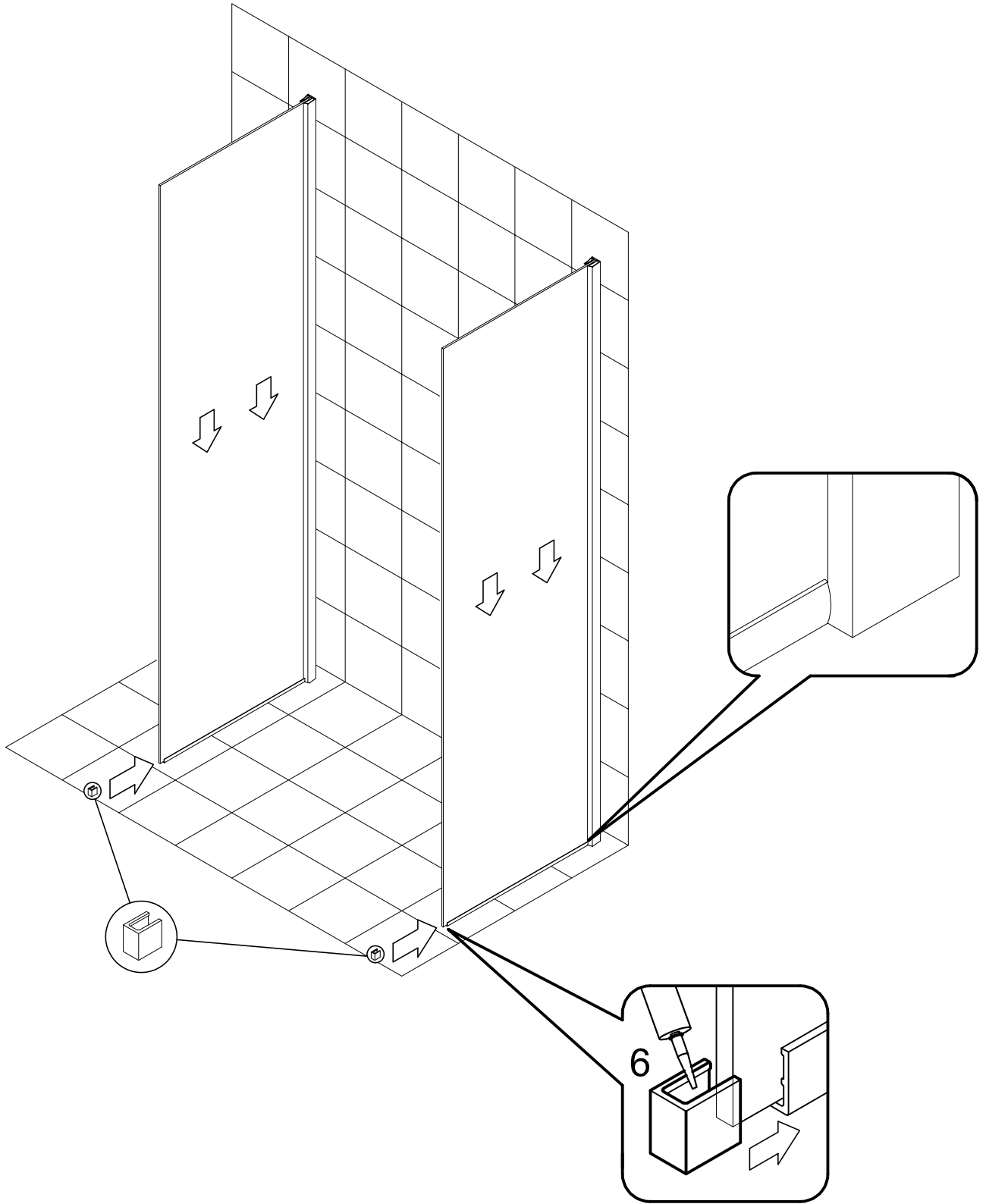

91

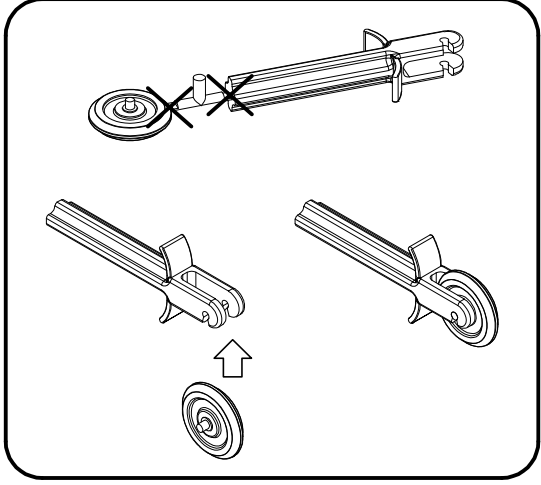
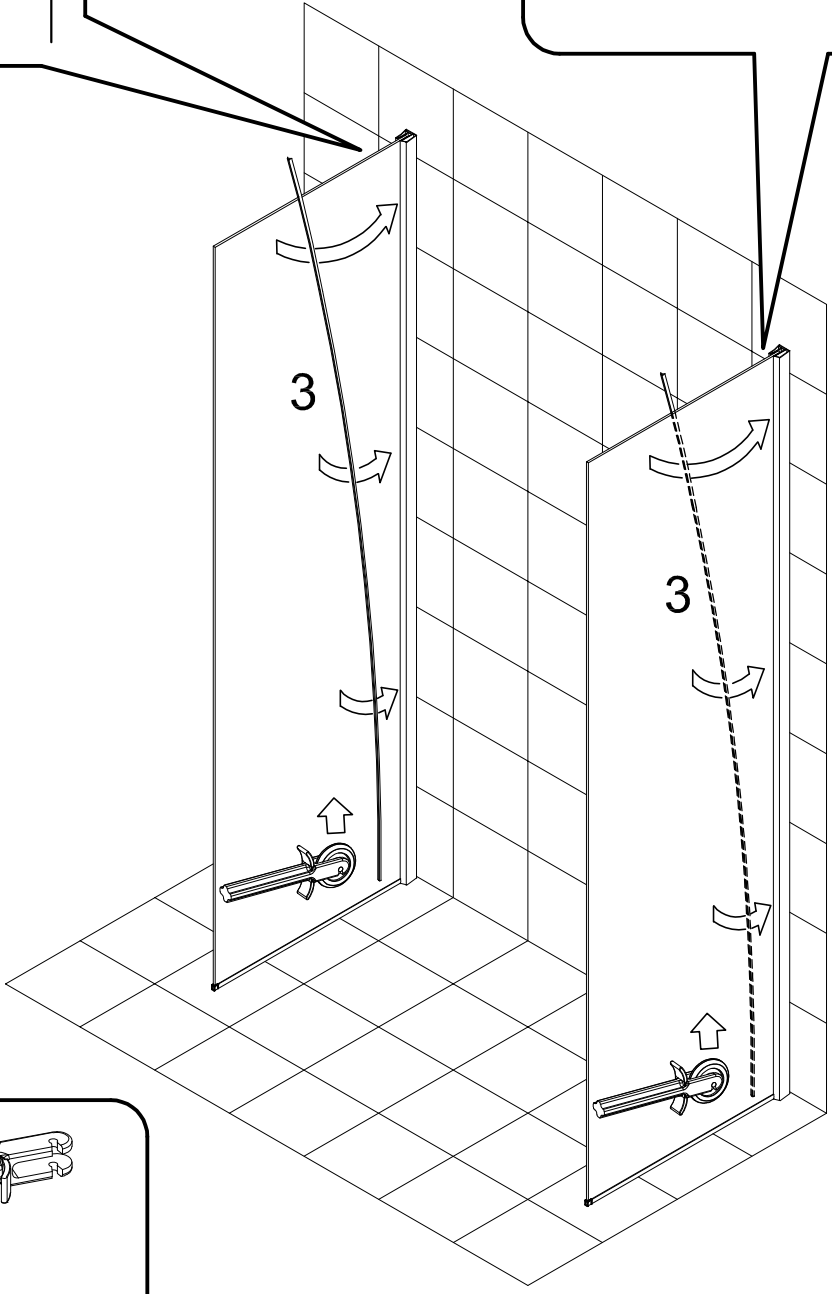
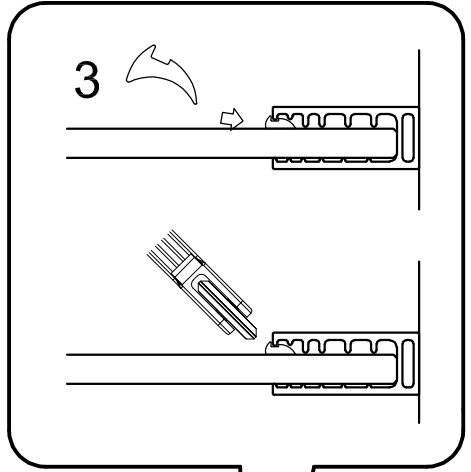
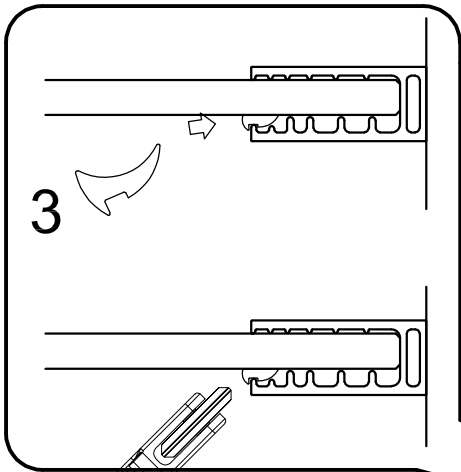

92

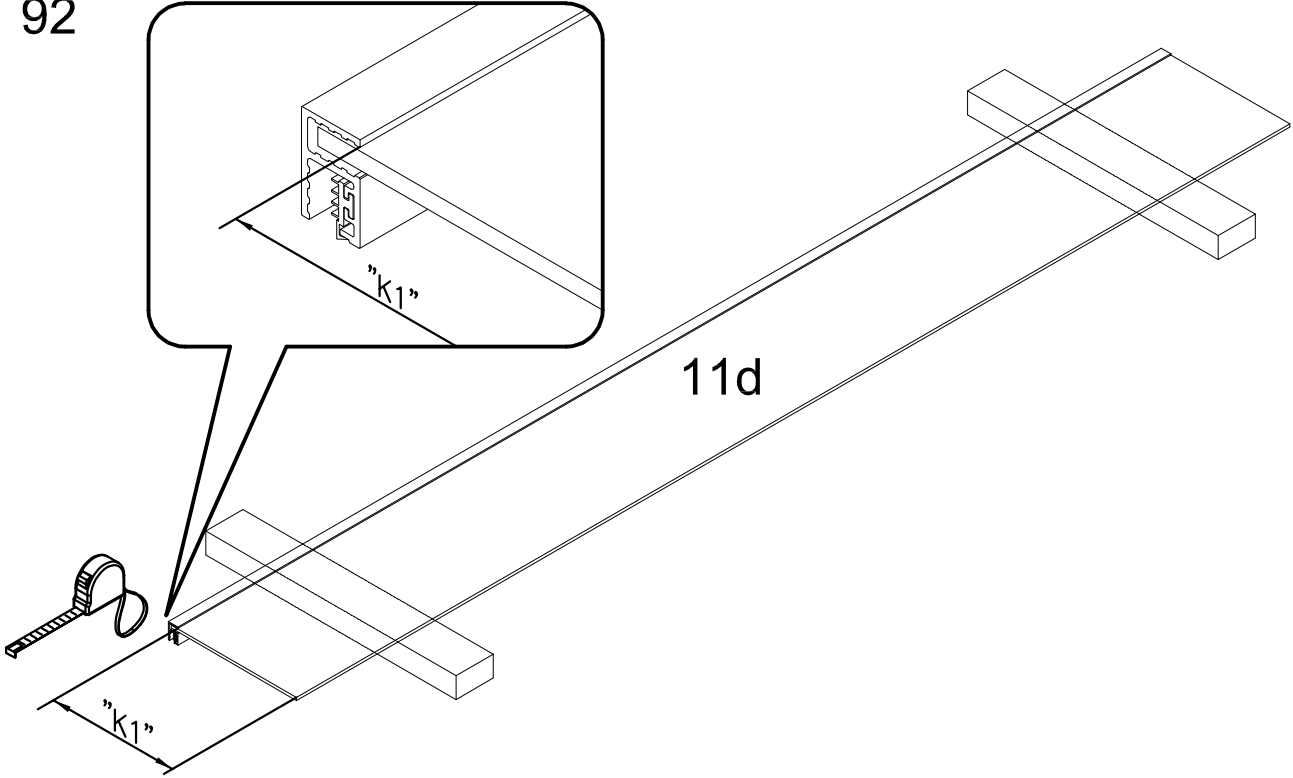

93

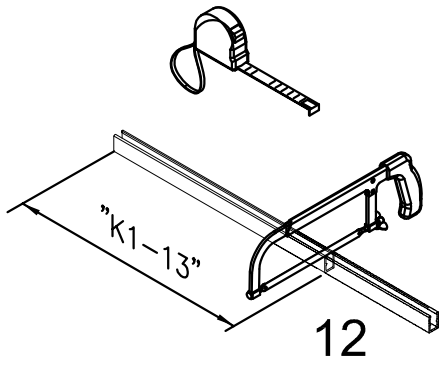

94

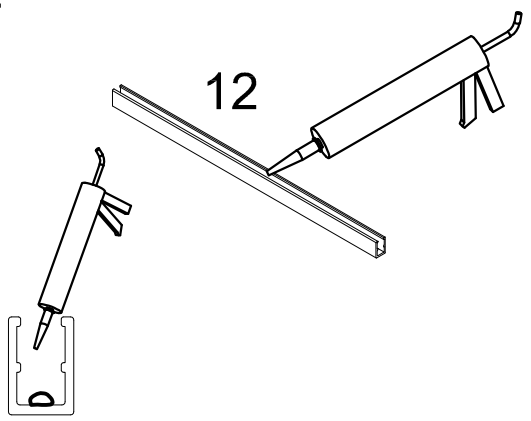

95

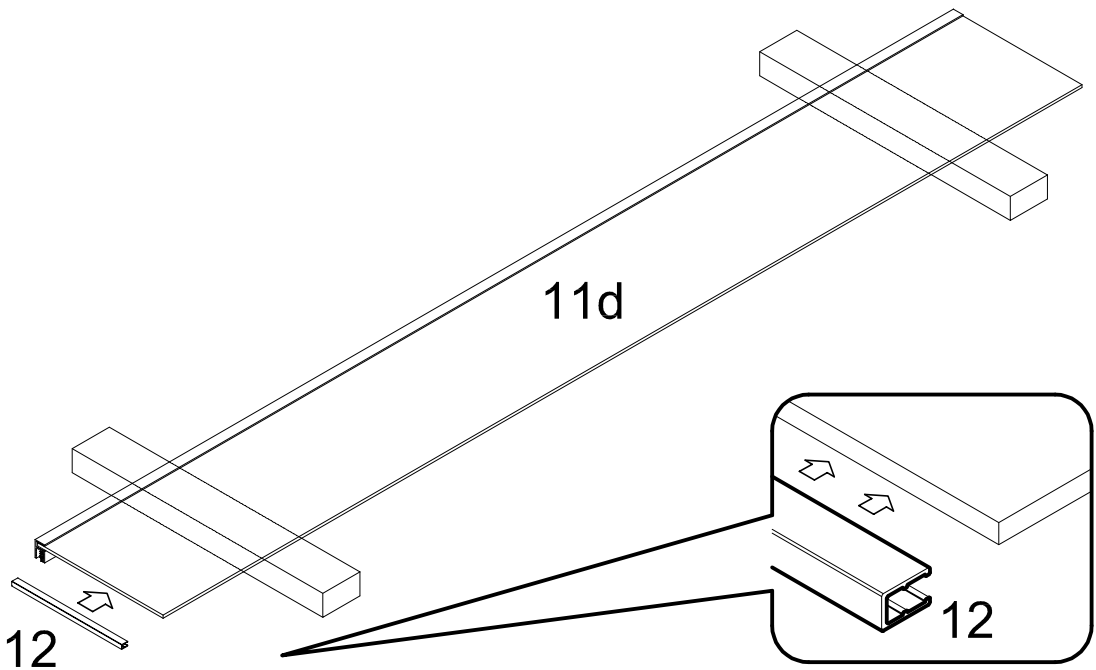

96

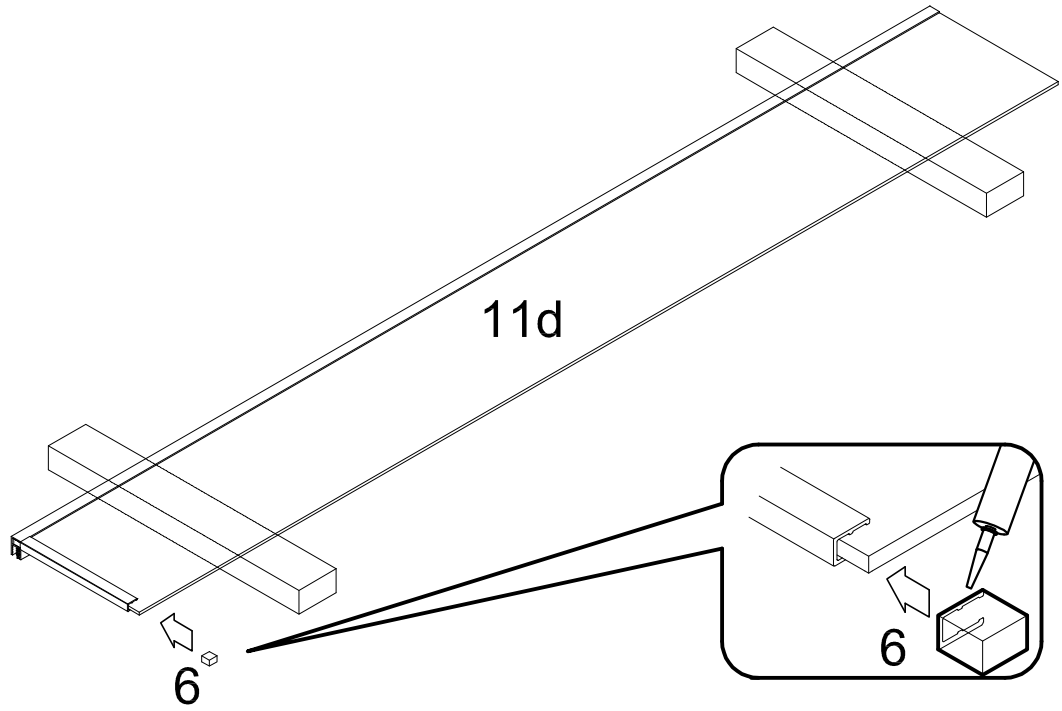

97

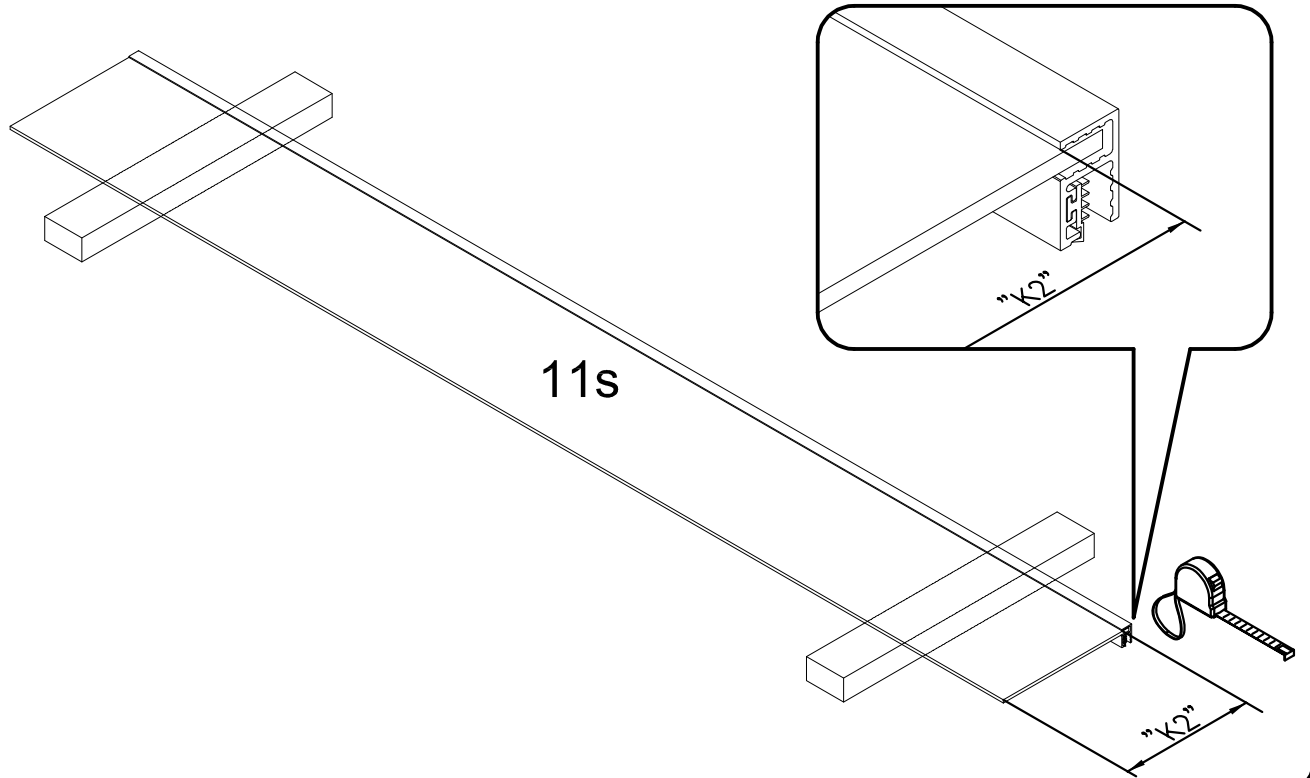

98

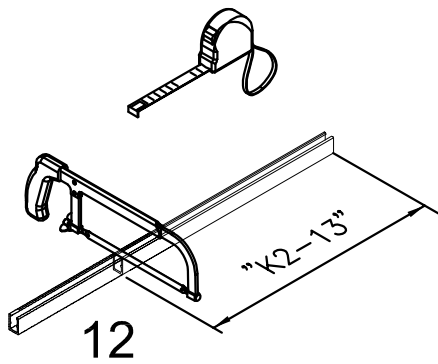

99

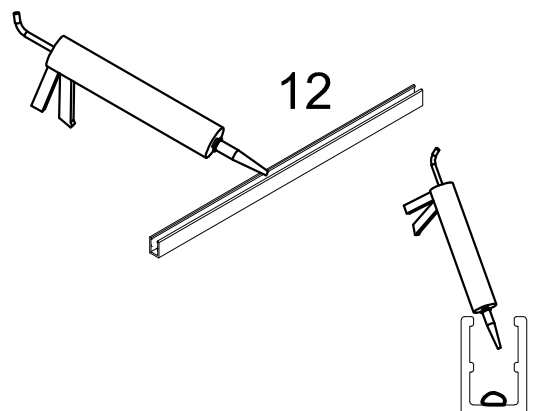

100

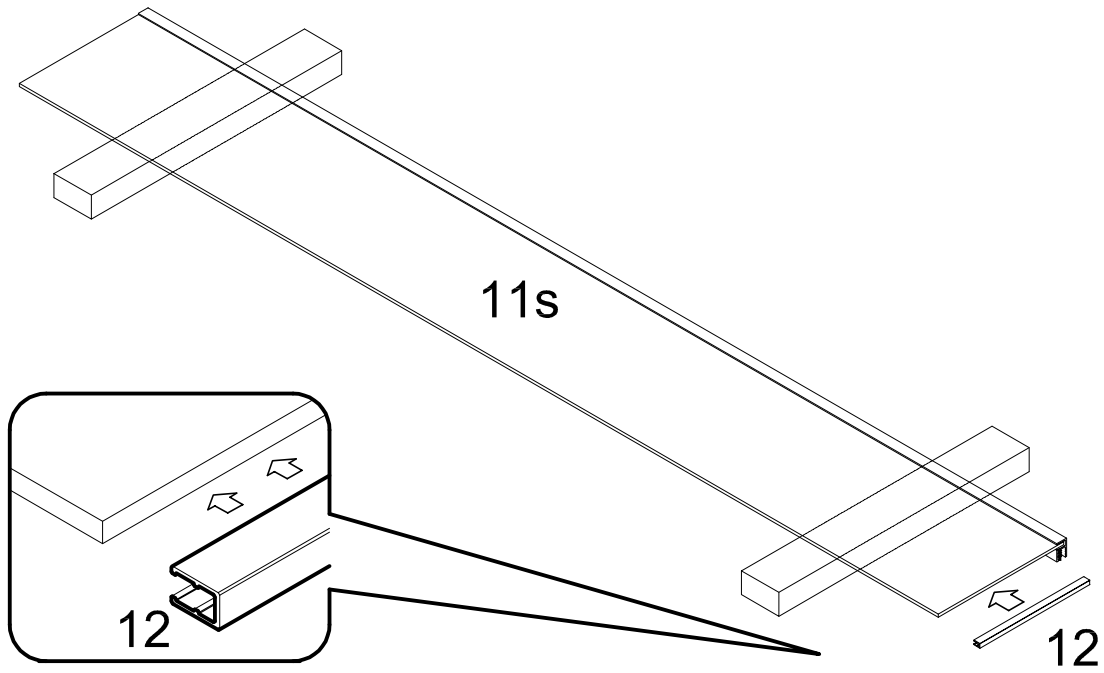

101

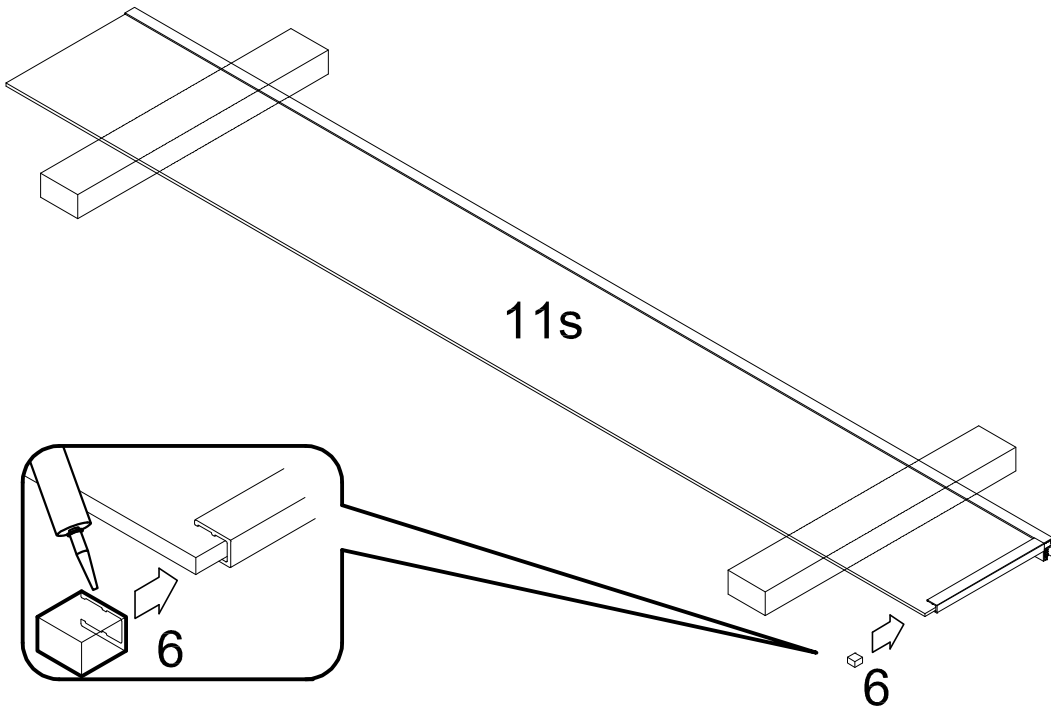

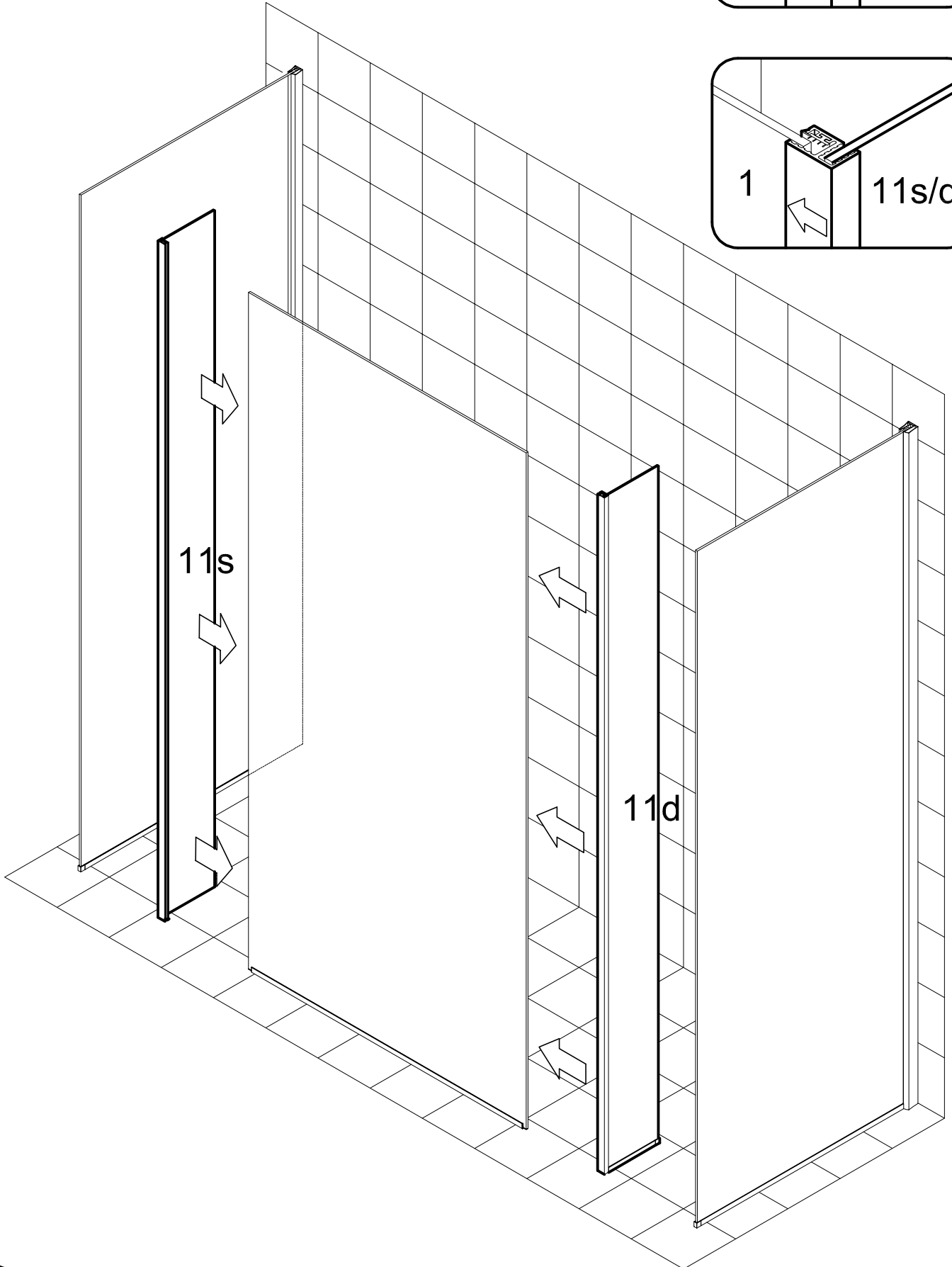
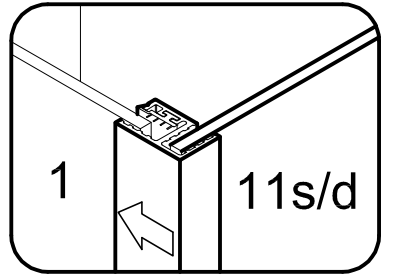
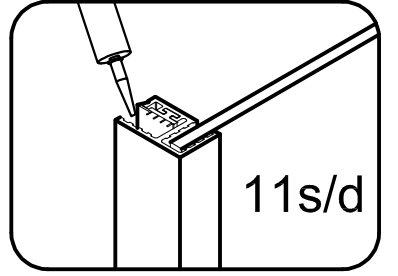

103

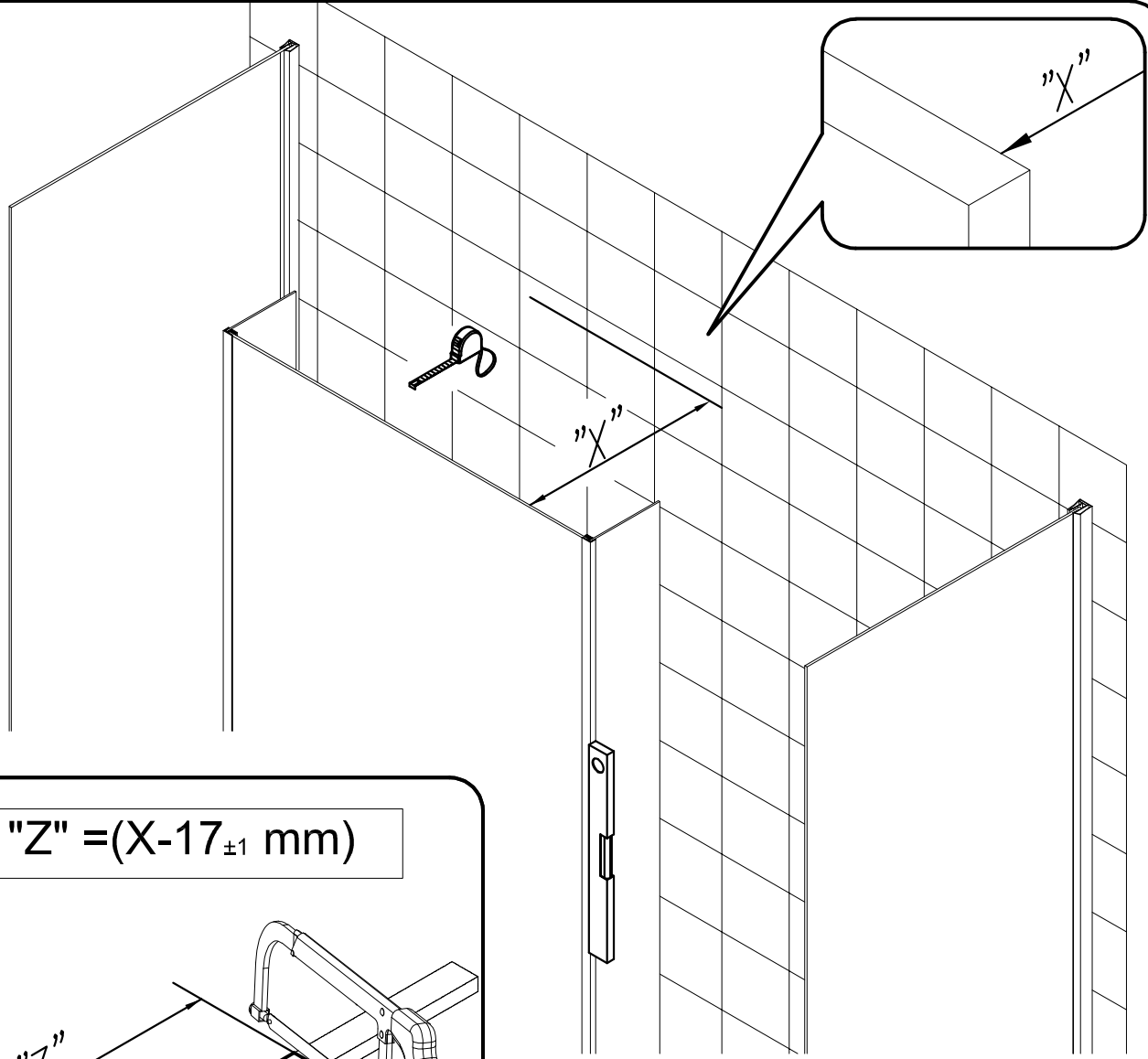

"Z" = (X - 17 ± 1 mm)

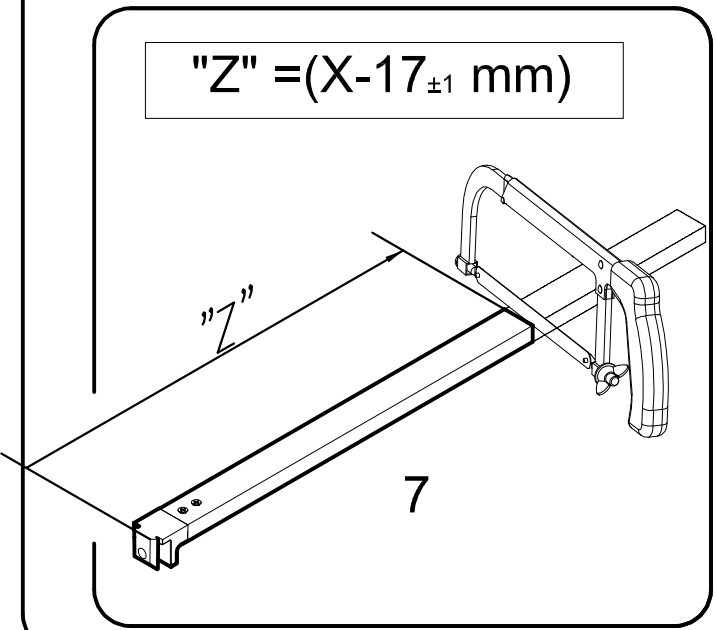

"X" max = 1200 mm

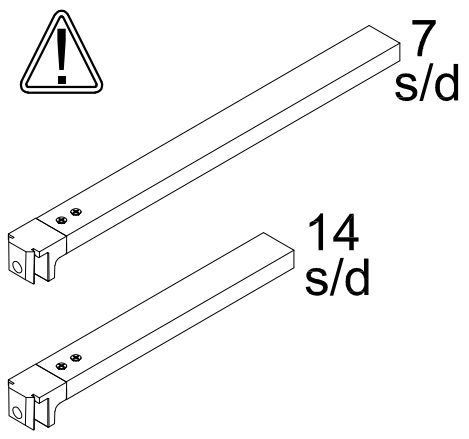

104

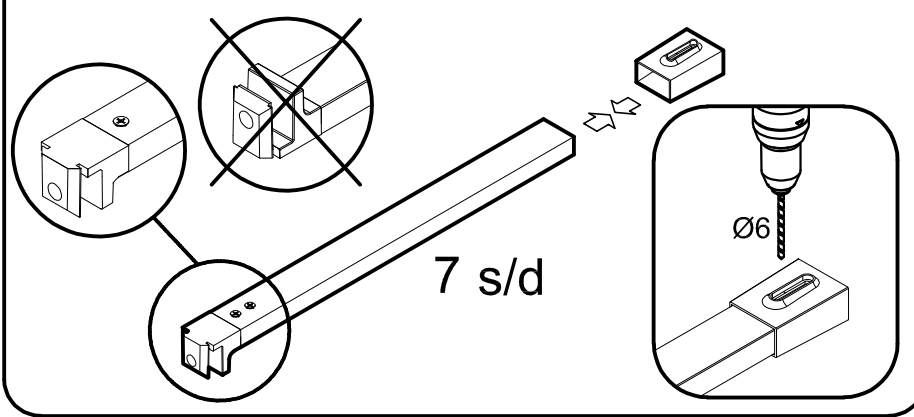

105

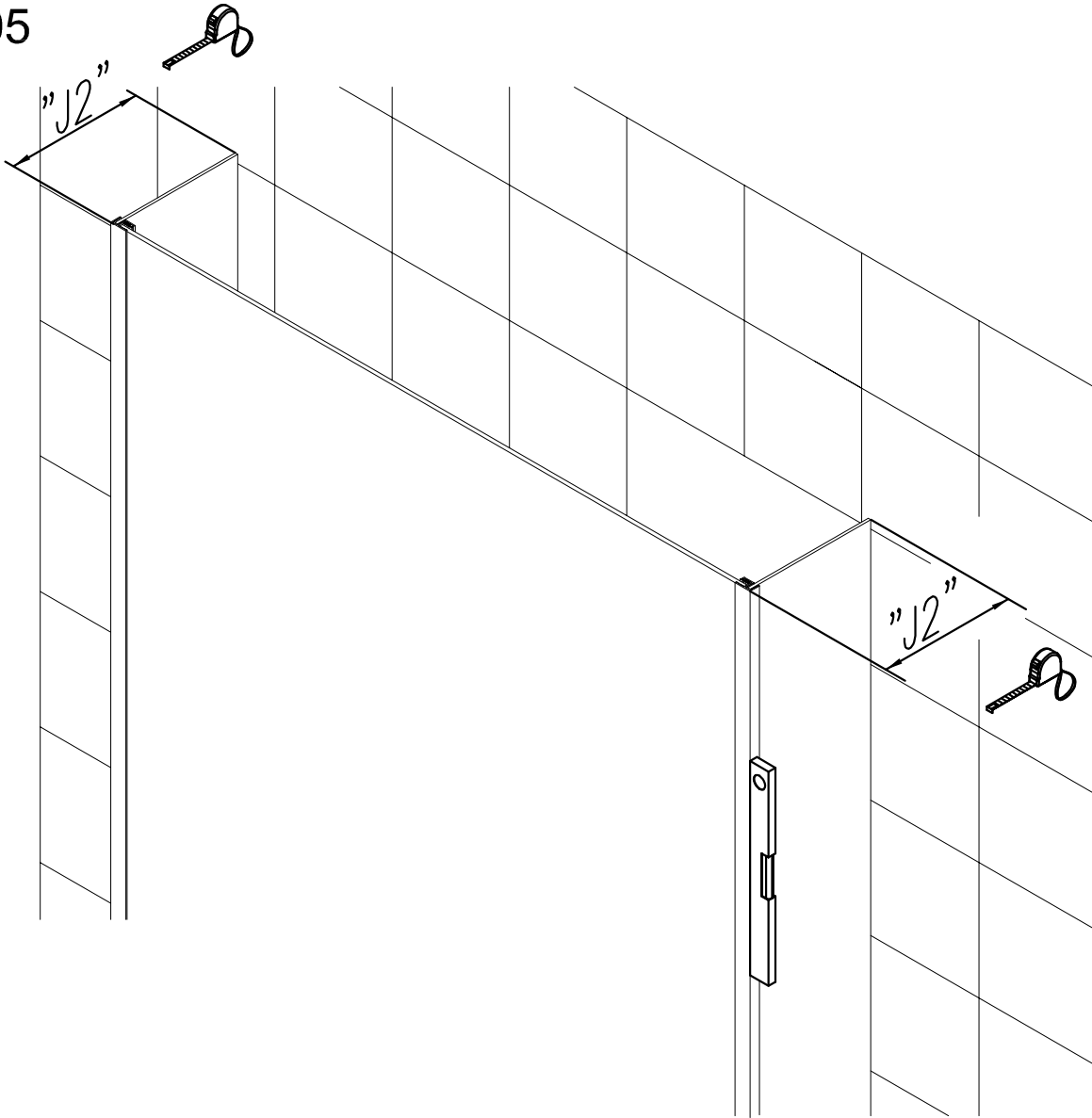

106

$$\text{"K1"} = (J1 + 20 \text{ mm})$$

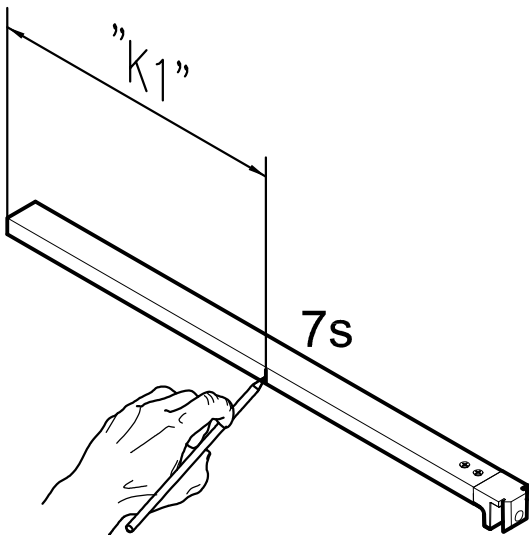

107

$$\text{"K2"} = (J2 + 20 \text{ mm})$$

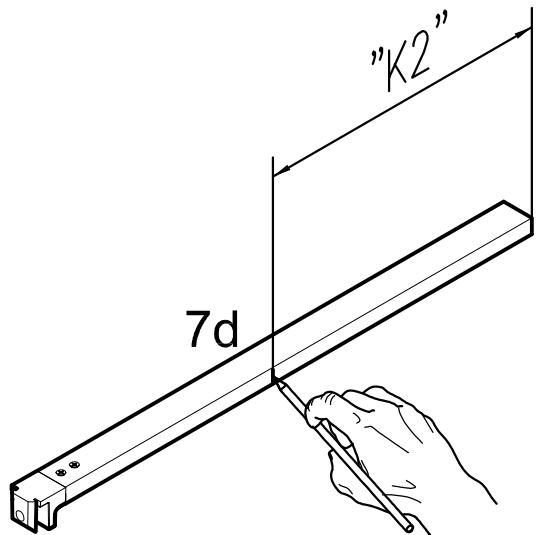

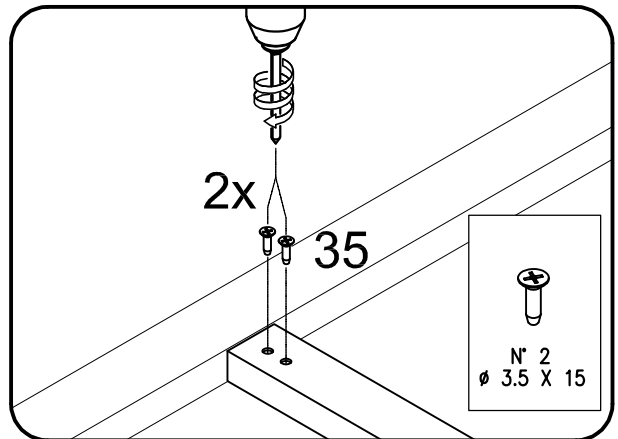
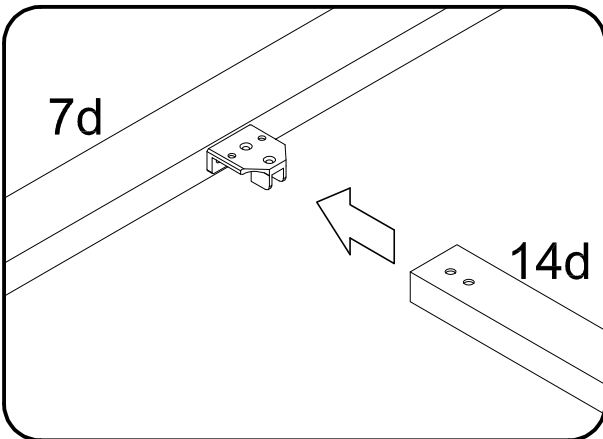
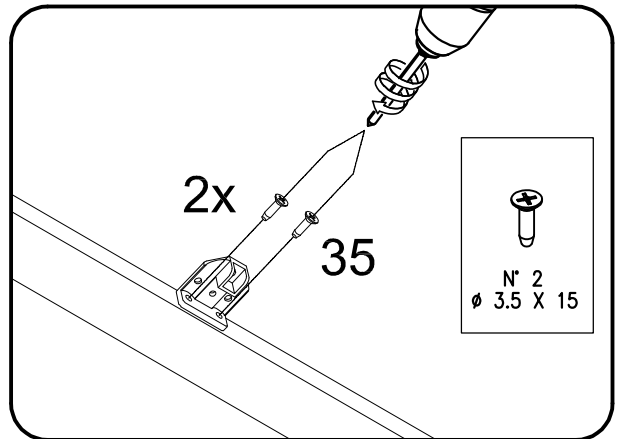
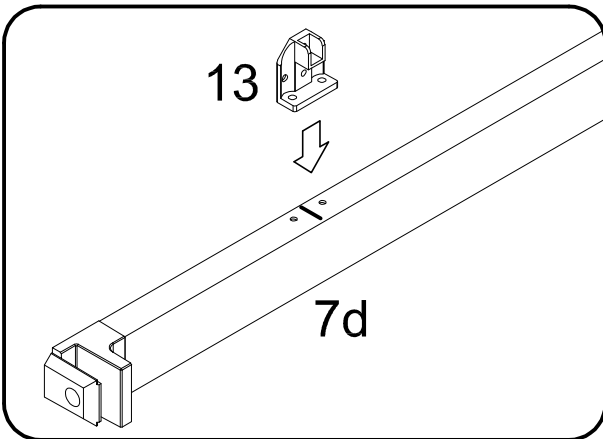
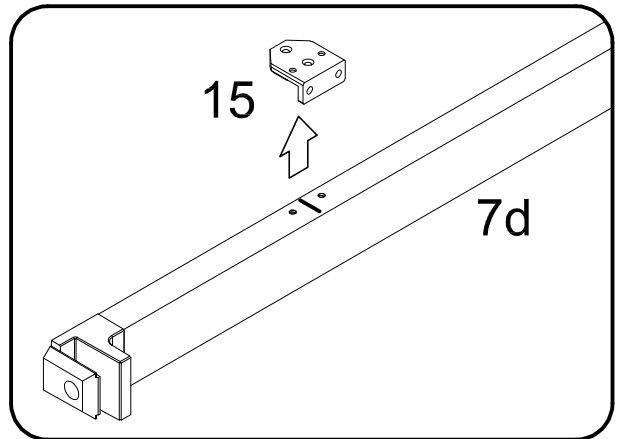
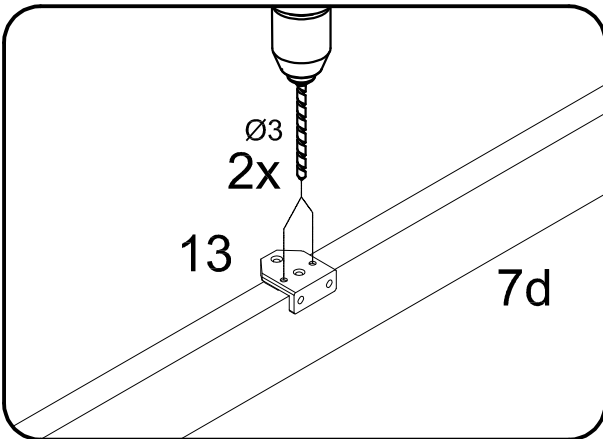
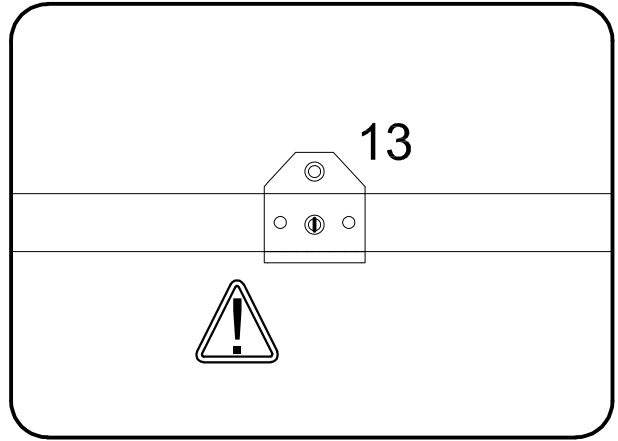
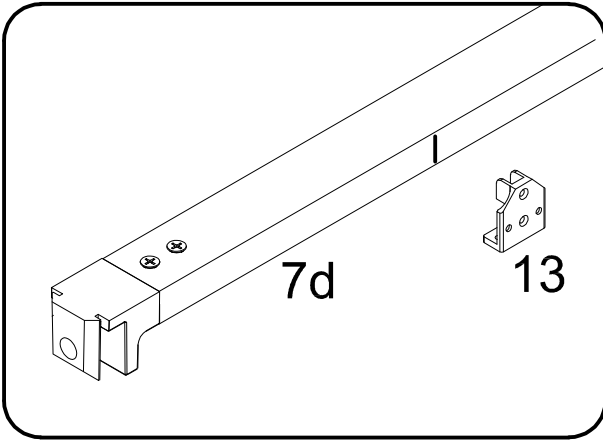

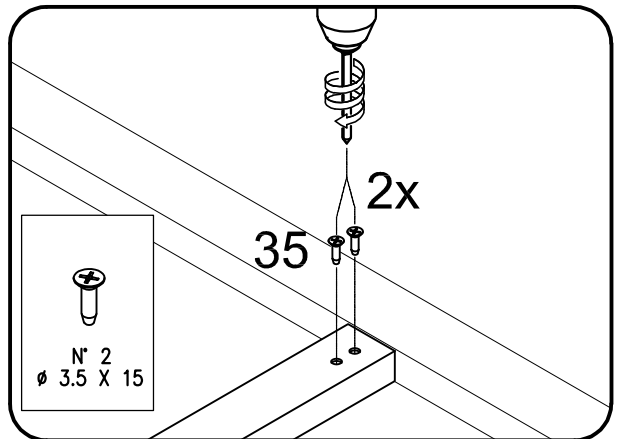
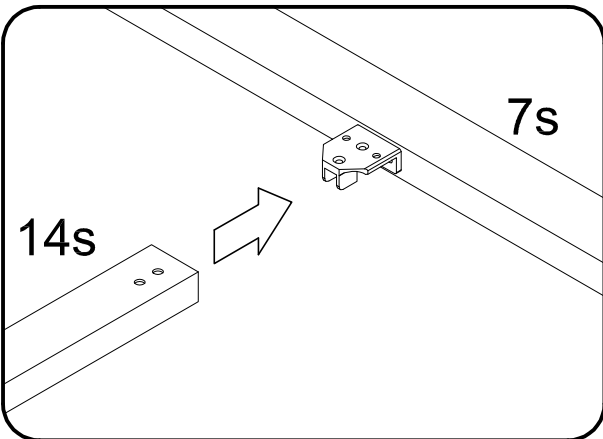
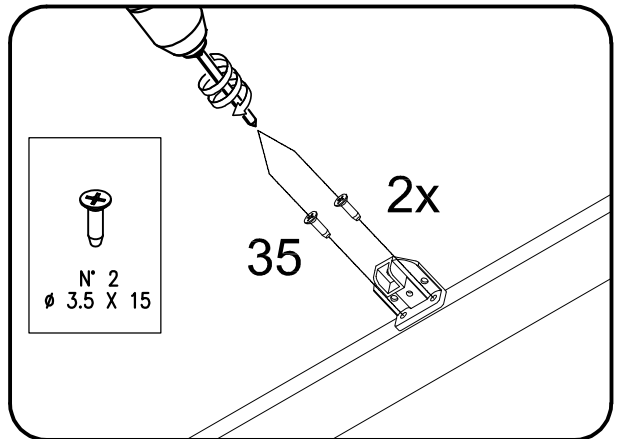
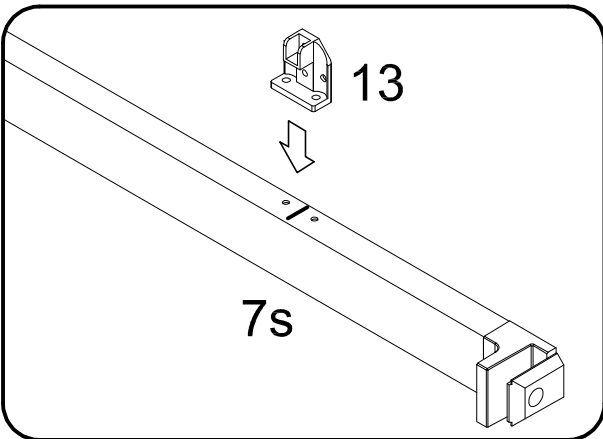
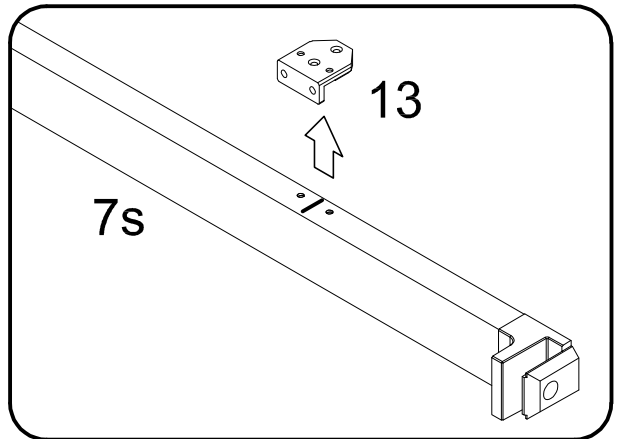
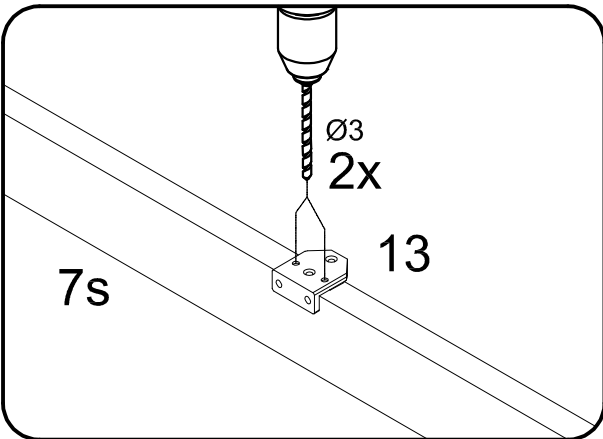
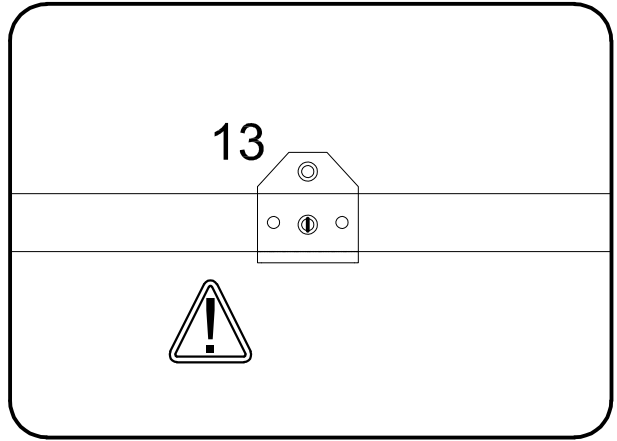
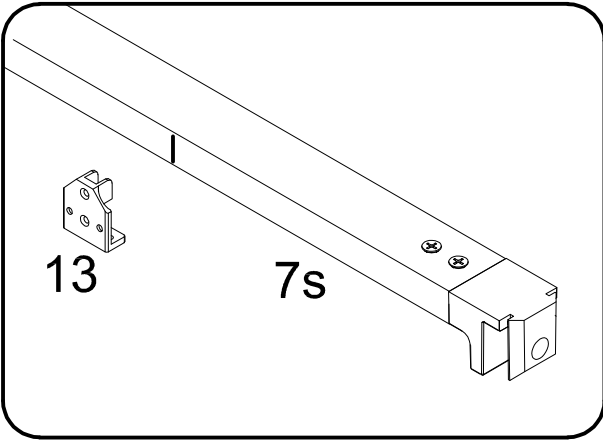

110

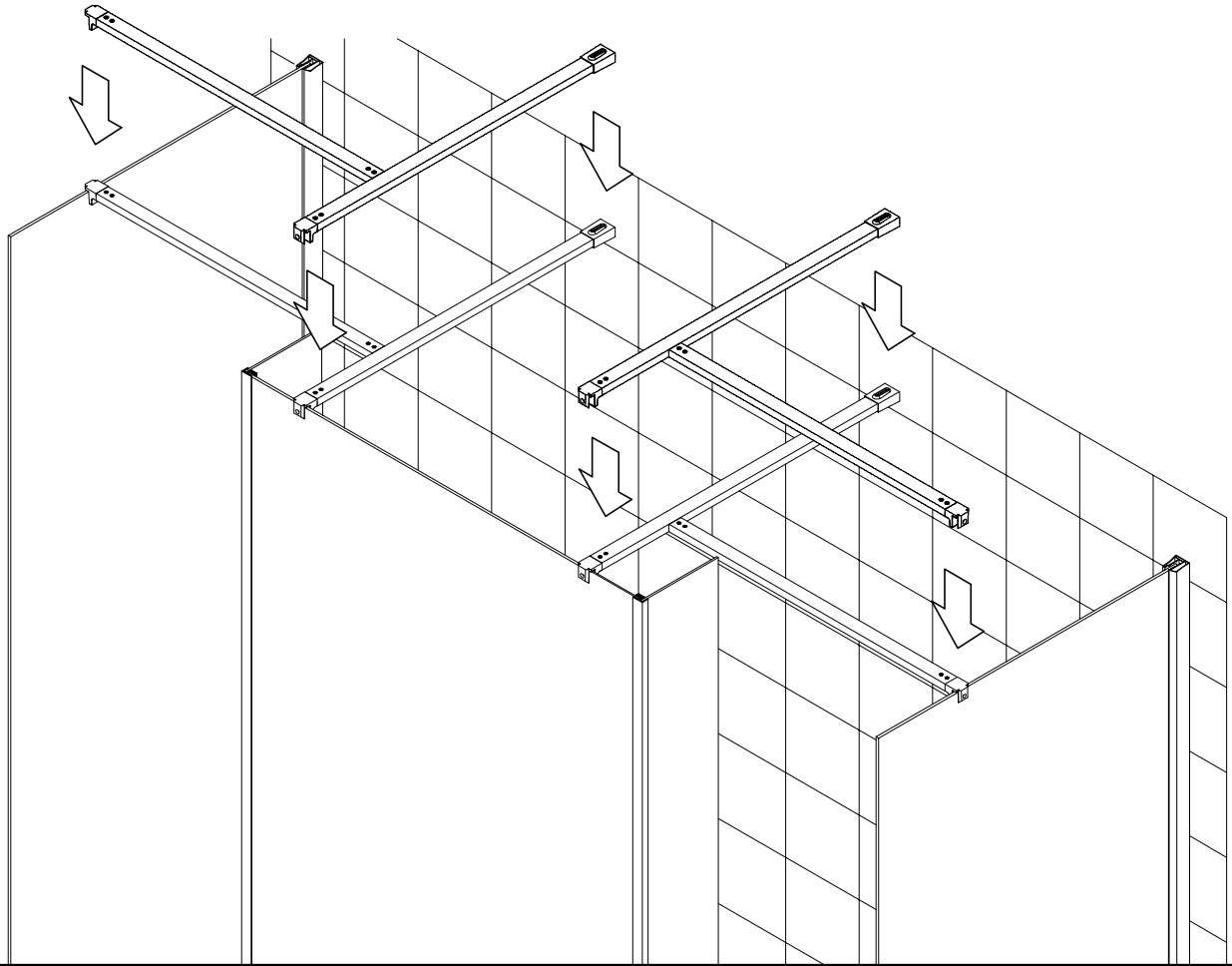

111

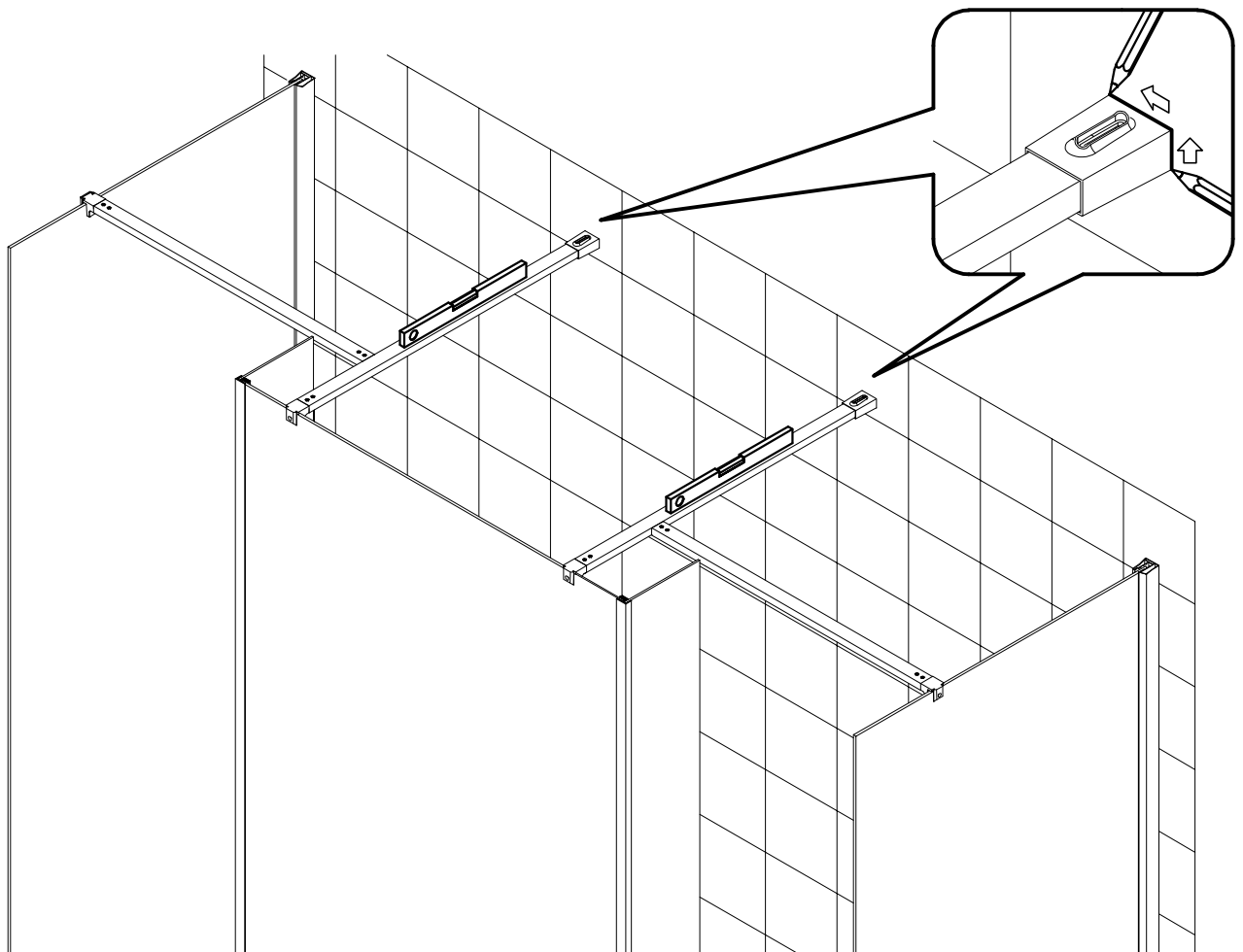

112

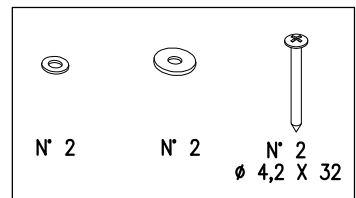
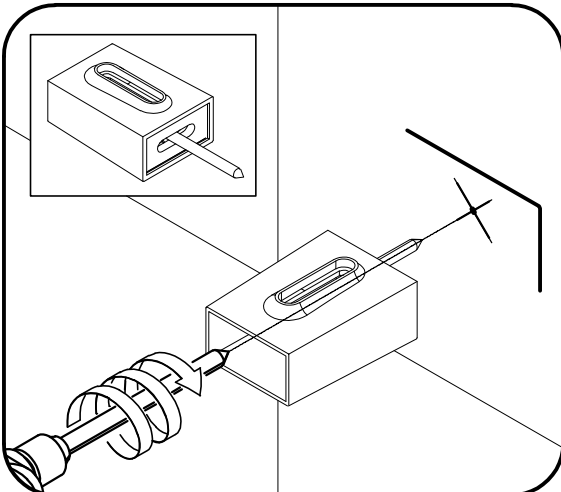
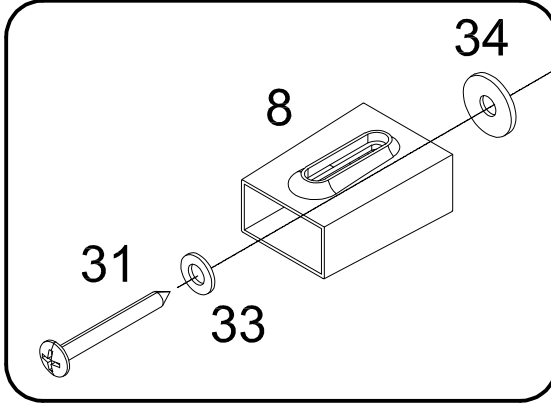
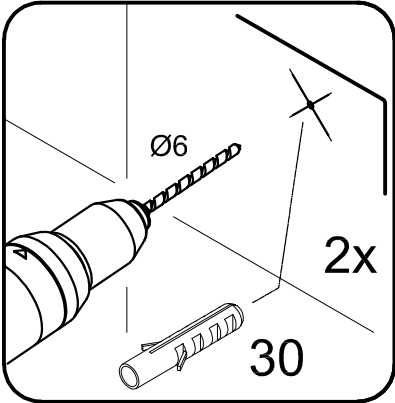
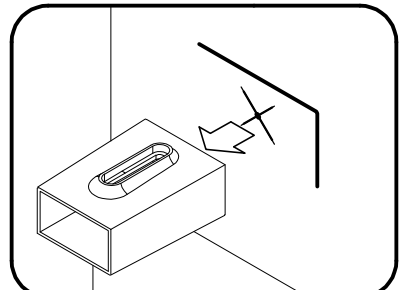
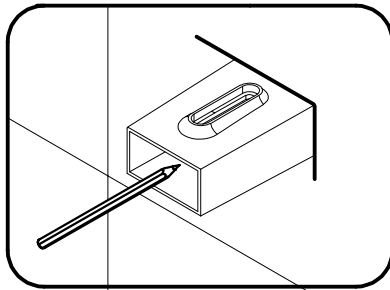
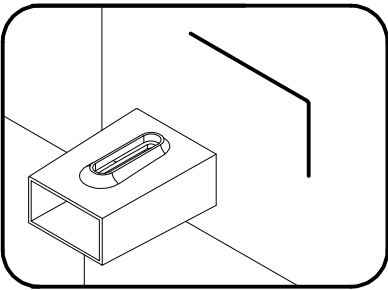
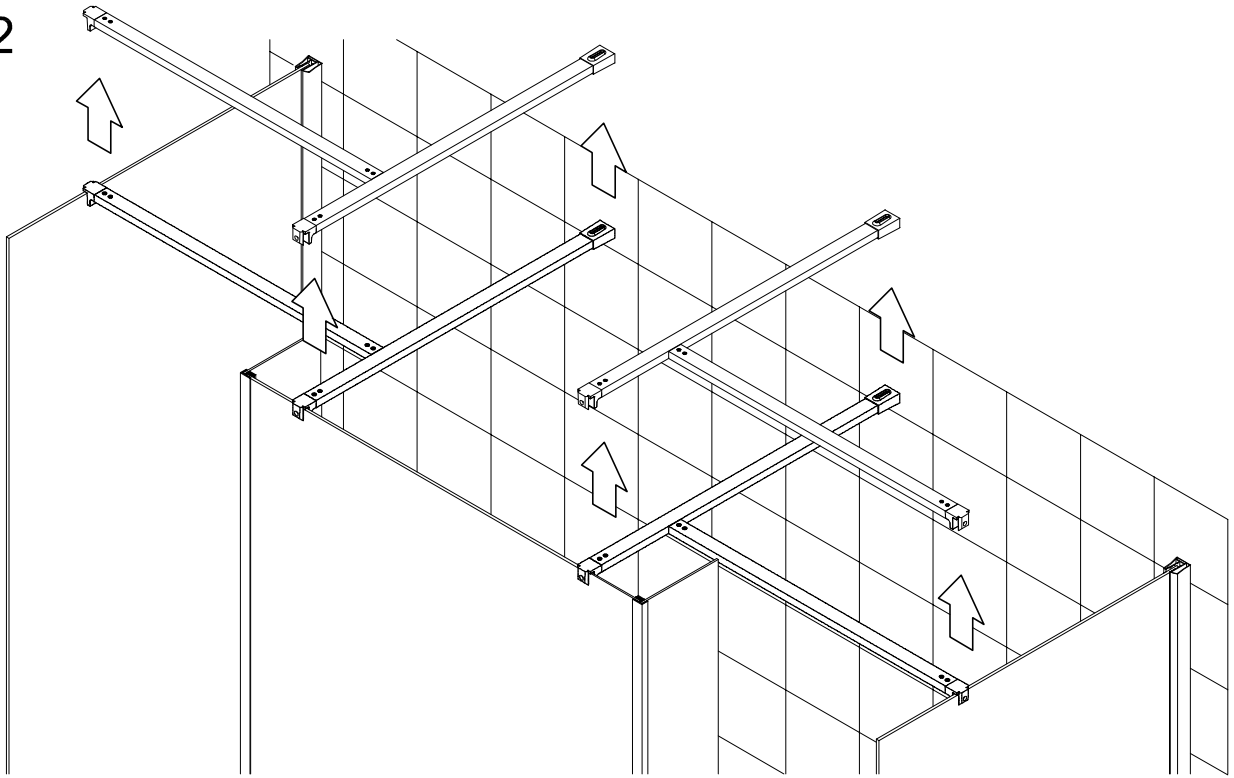

113

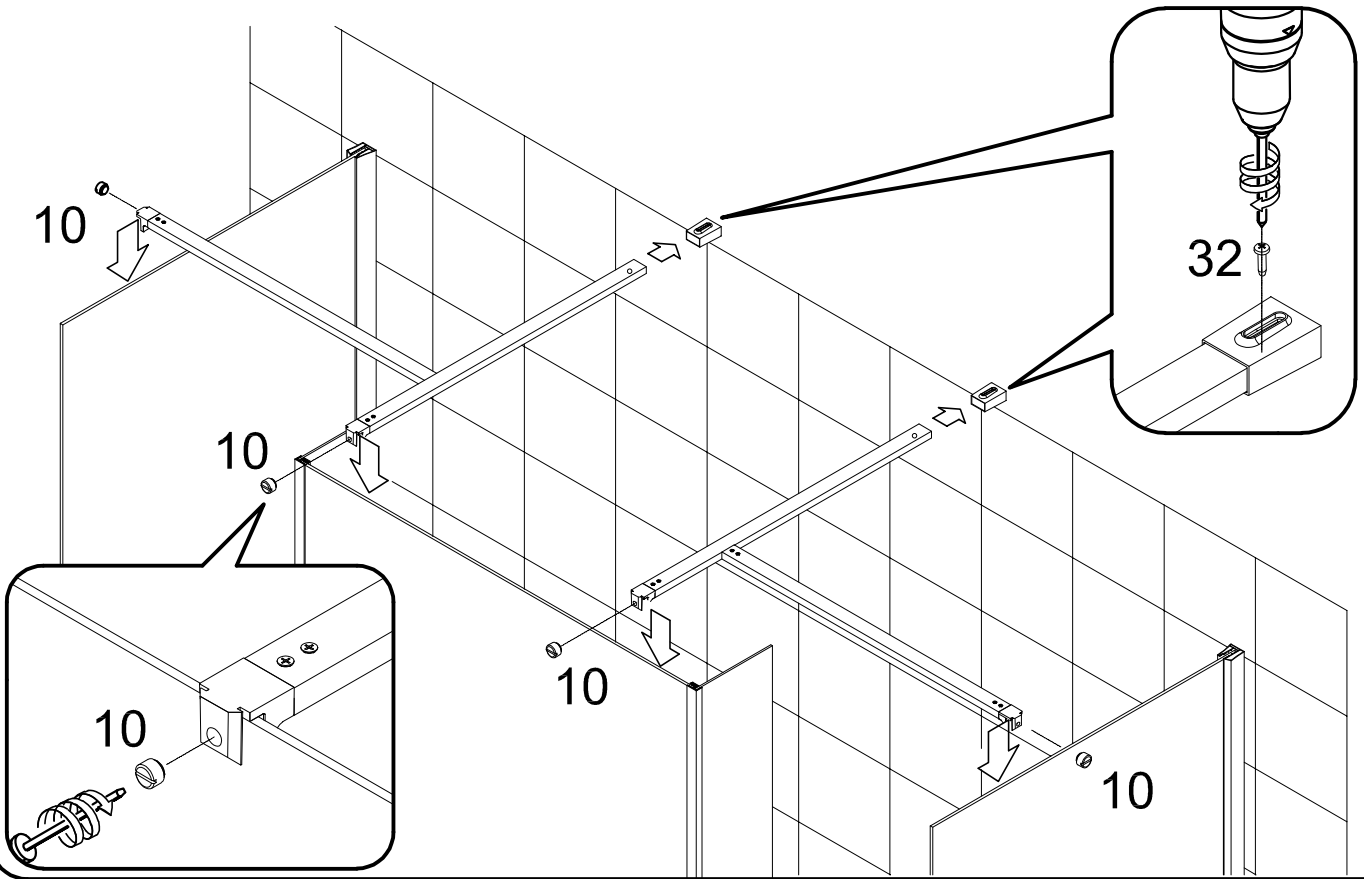

114

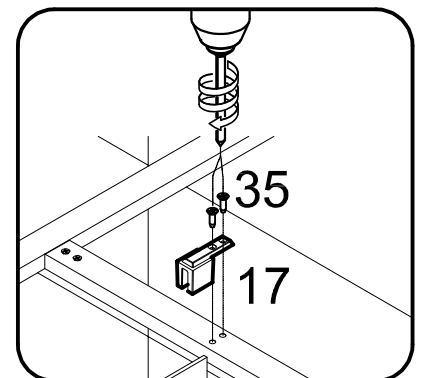
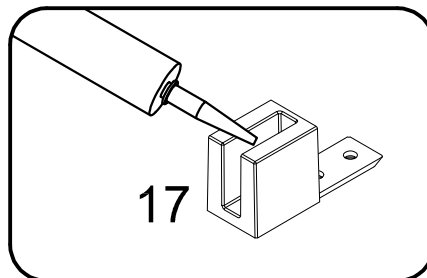
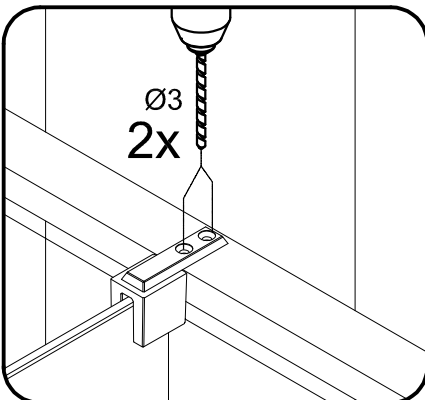
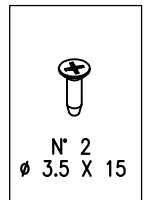
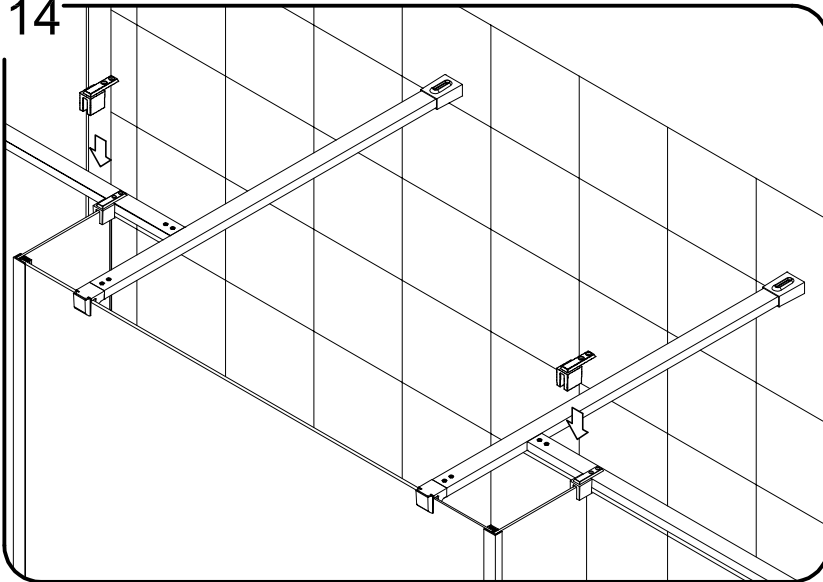

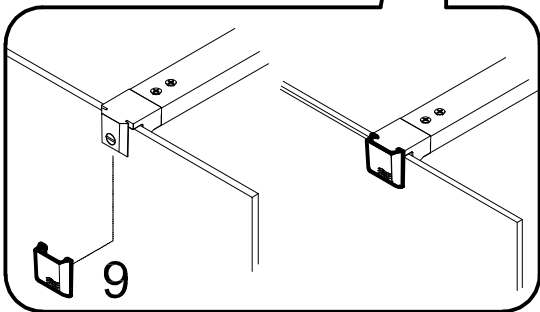
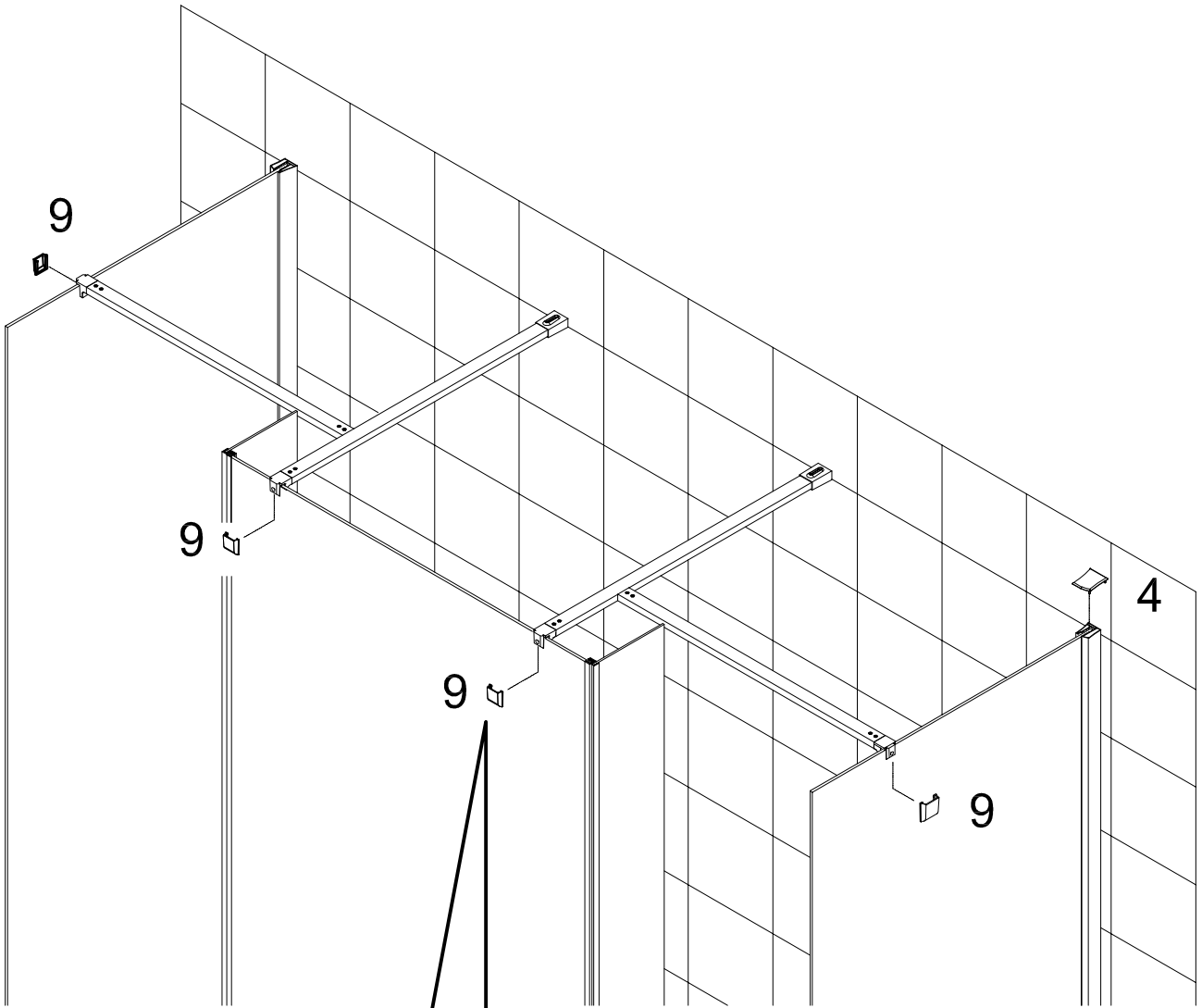



Pag. 1

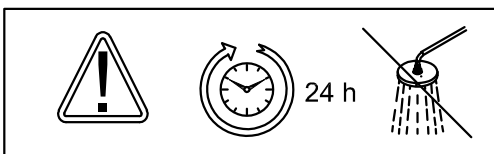
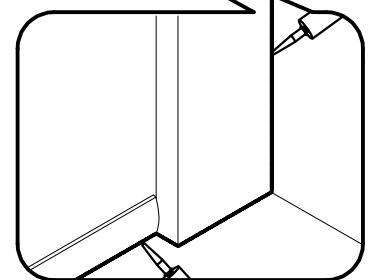
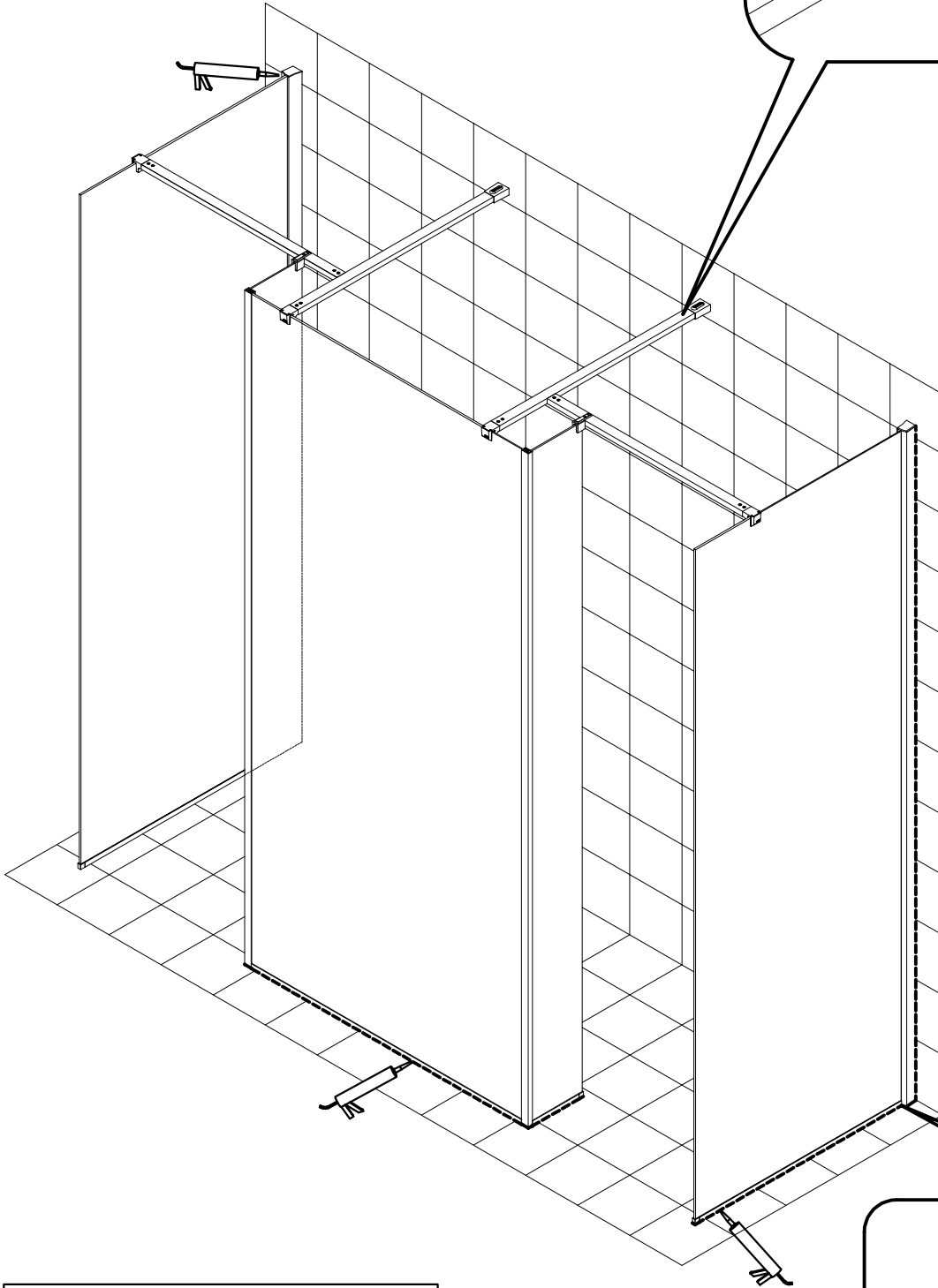
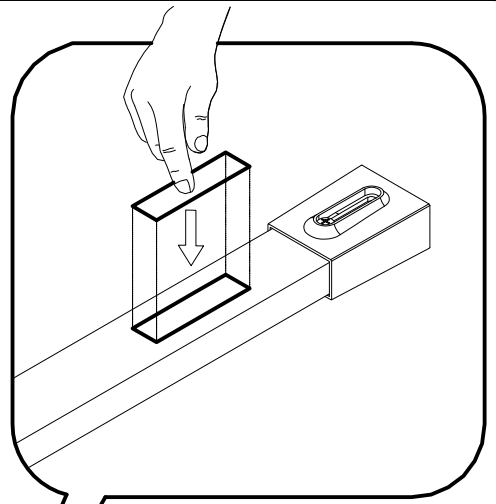
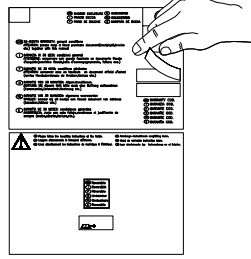



Customer care: tel +39 0363 38069 - fax +39 0363 380635

www.inda.net