

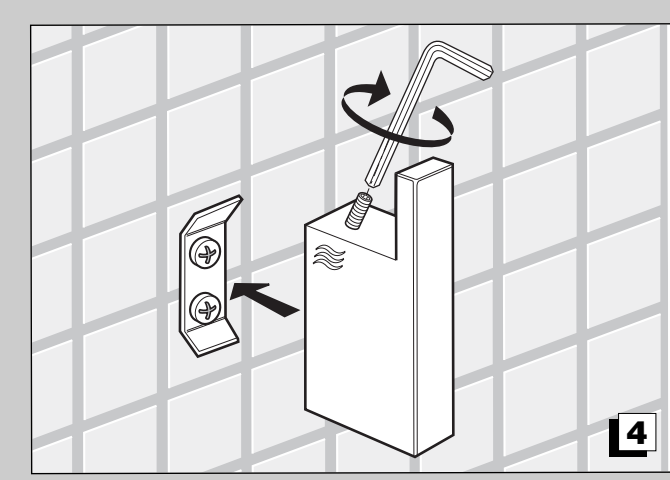

ACCESSORI  
ACCESSORIES  
ACCESSOIRES  
ACCESSOIRES  
ACCESORIOS  
ACCESORIOS

# Divo 1500

- I** ISTRUZIONI DI MONTAGGIO
- GB** MOUNTING INSTRUCTIONS
- F** INSTRUCTIONS DE MONTAGE
- D** MONTAGEANWEISUNGEN
- NL** MONTAGEINSTRUCTIES
- E** INSTRUCCIONES DE MONTAJE
- P** INSTRUÇÕES DE MONTAGEM

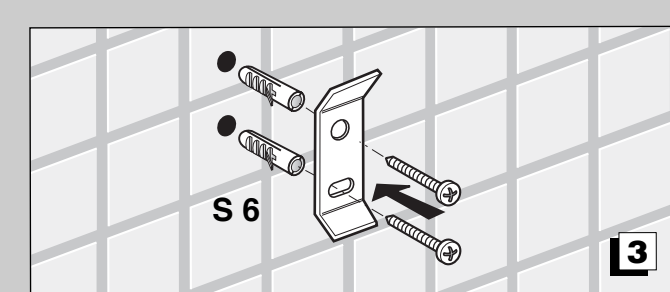
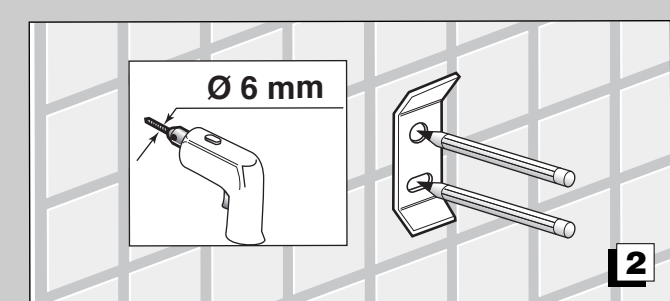
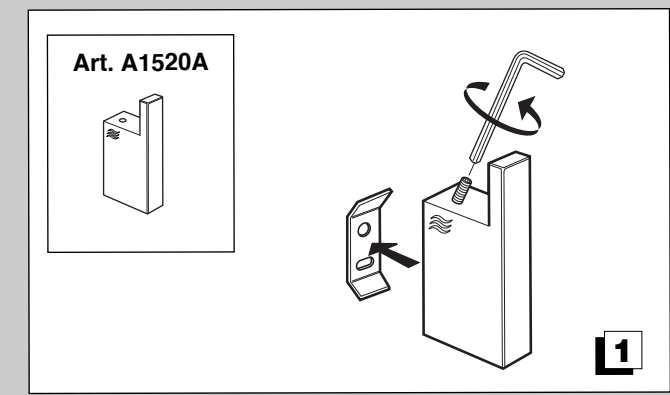
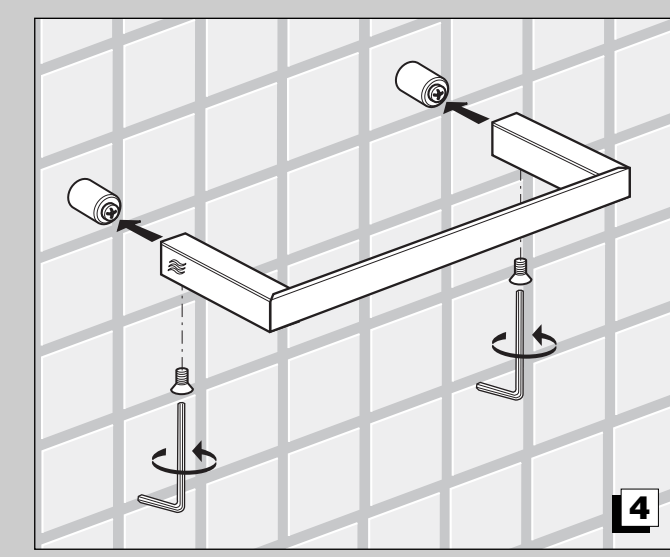
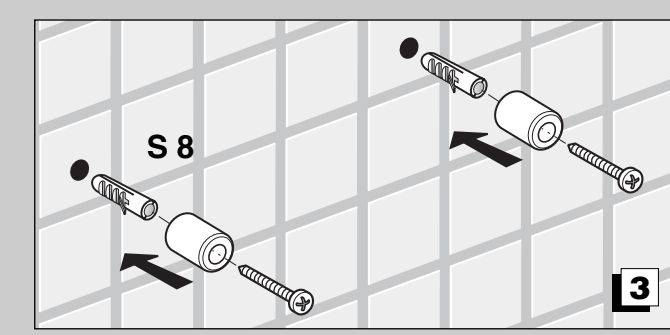
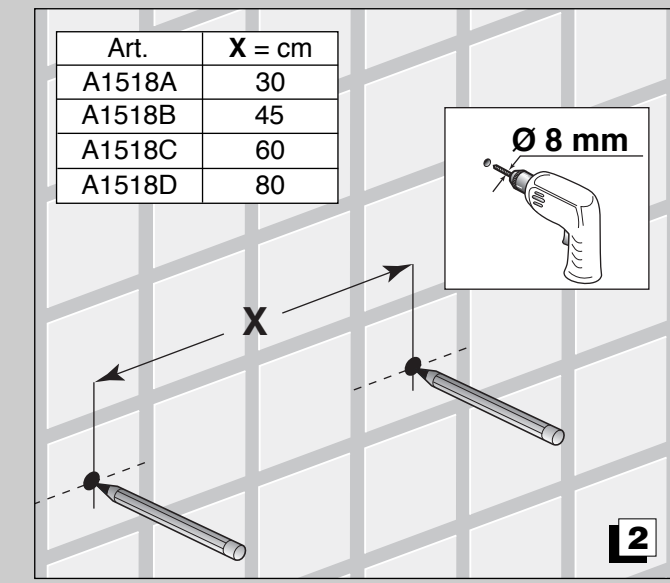
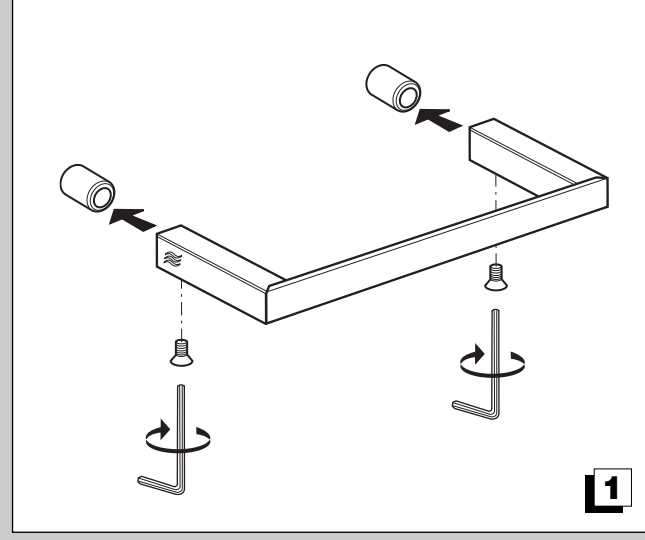
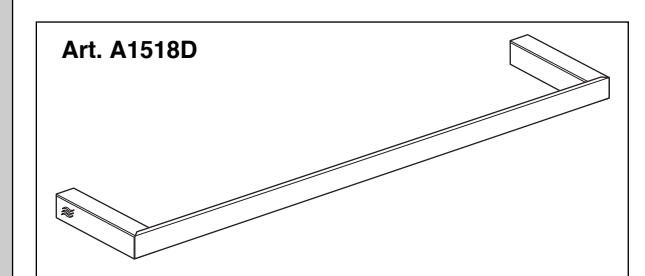
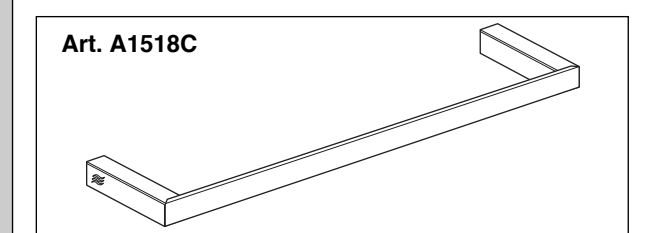
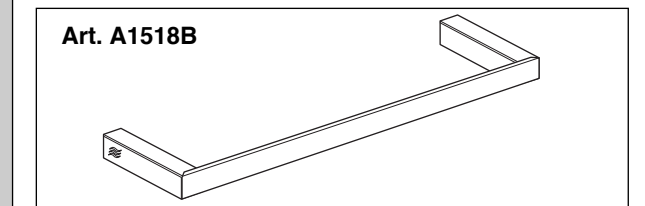
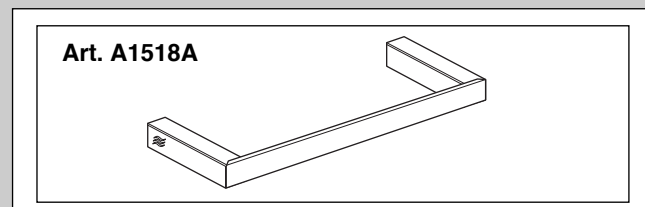
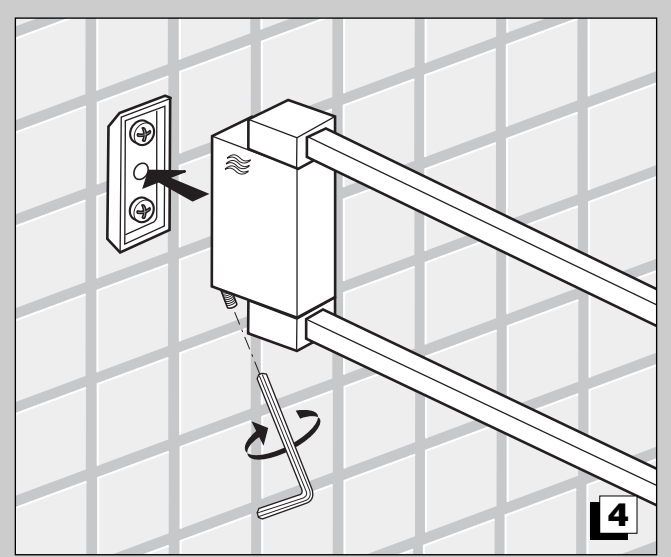
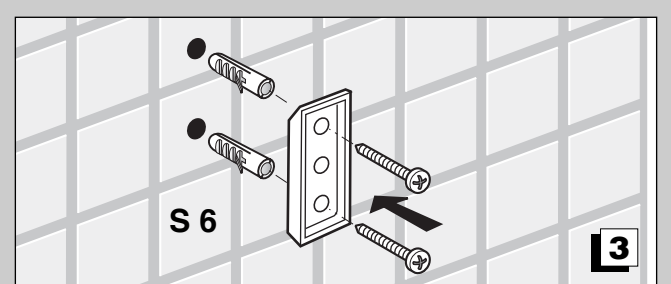
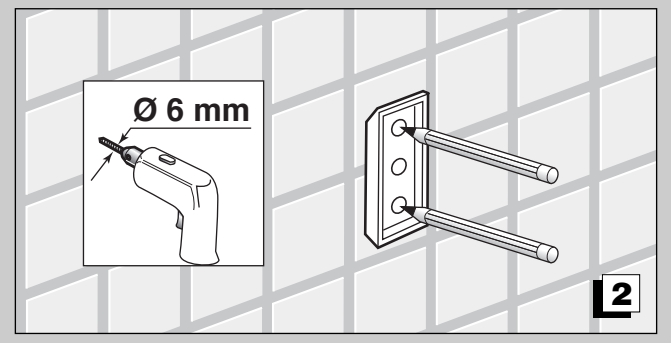
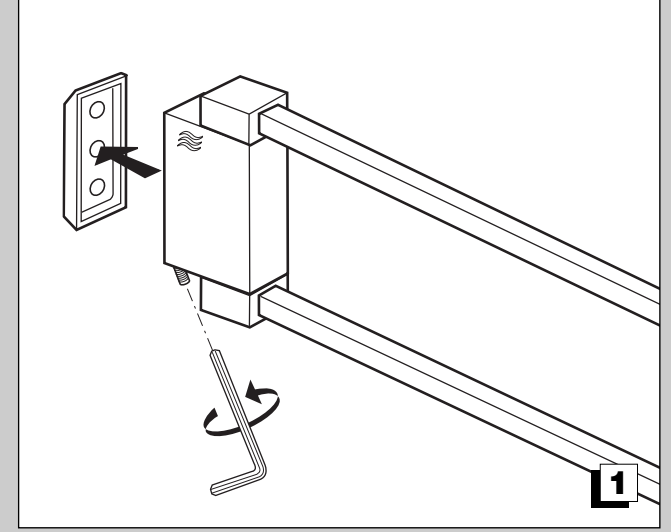
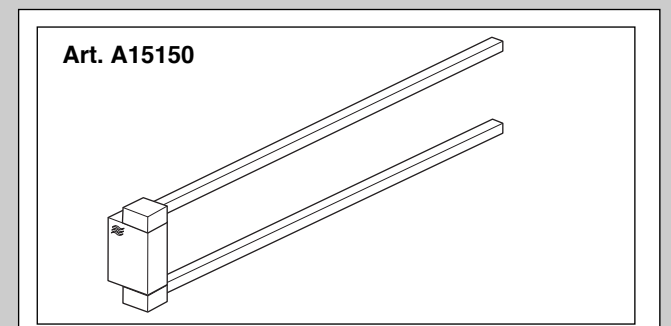
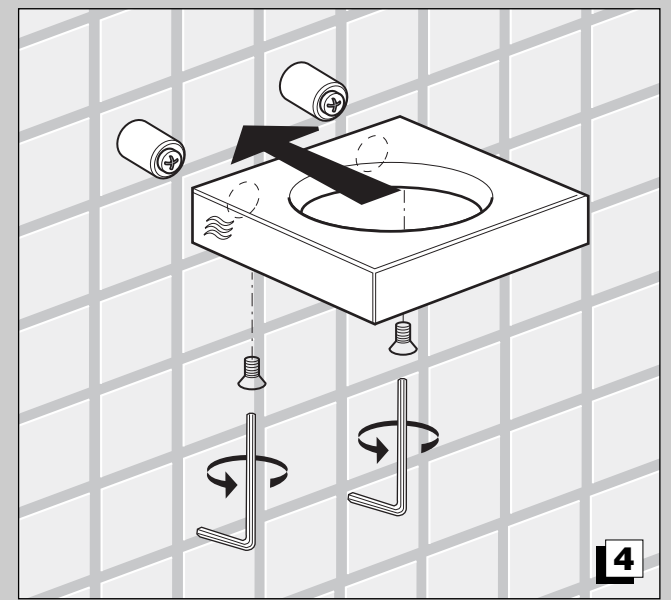
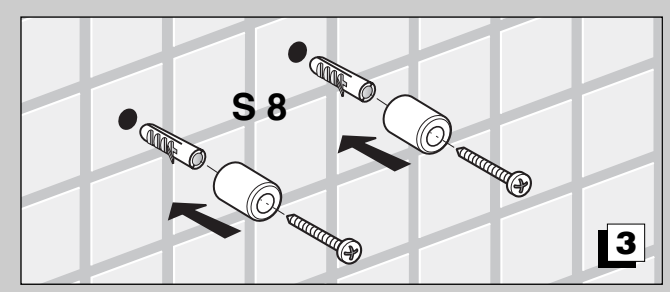
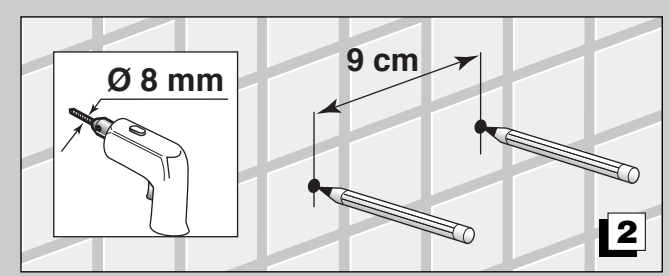
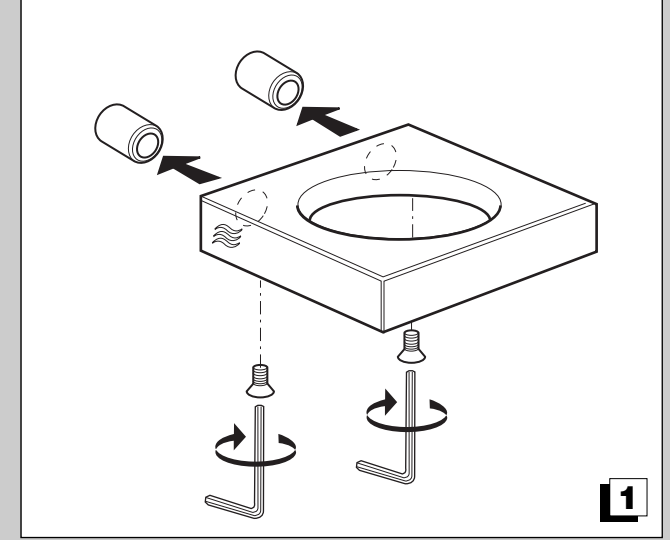
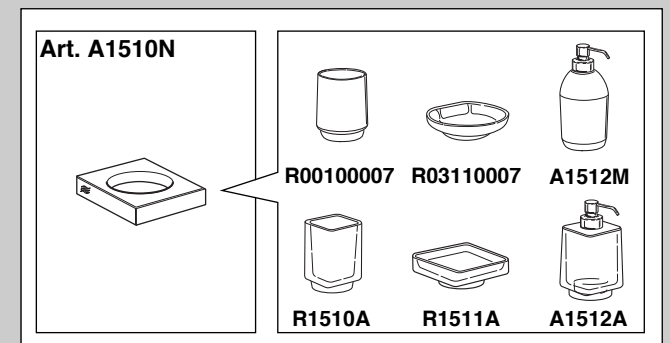

INDA srl - Via dell'Industria, 41  
24040 Pagazzano (BG)  
Tel. +39 0363 38061 - Fax +39 0363 070035  
www.inda.net

11/2011

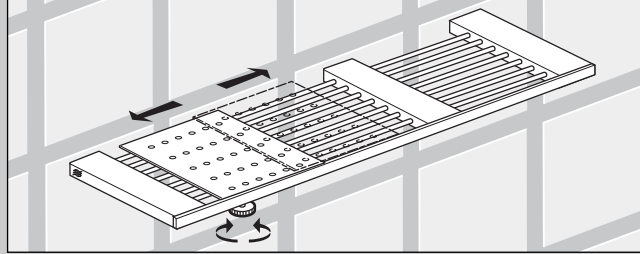
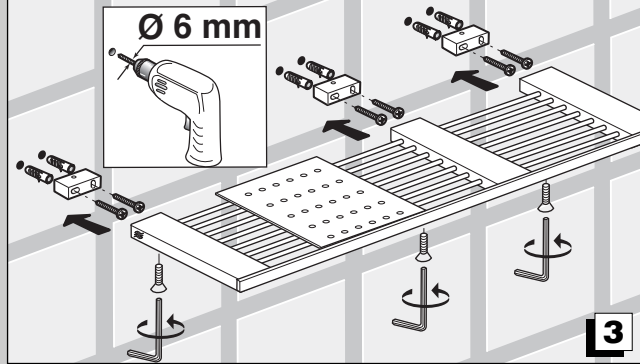
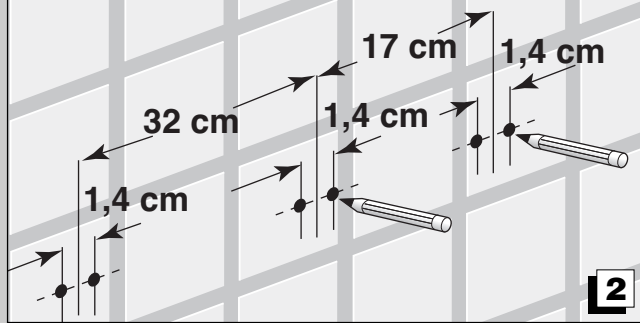
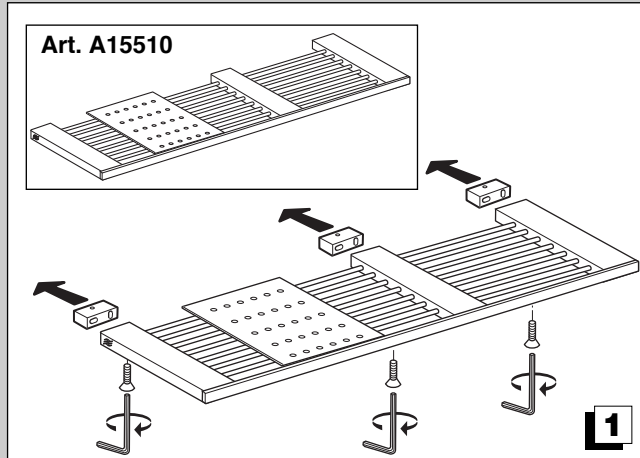
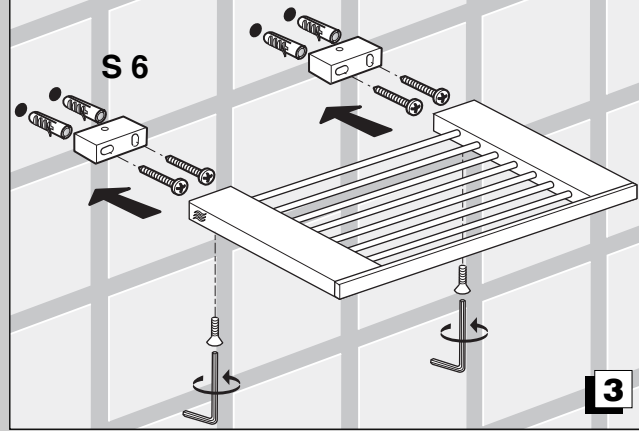
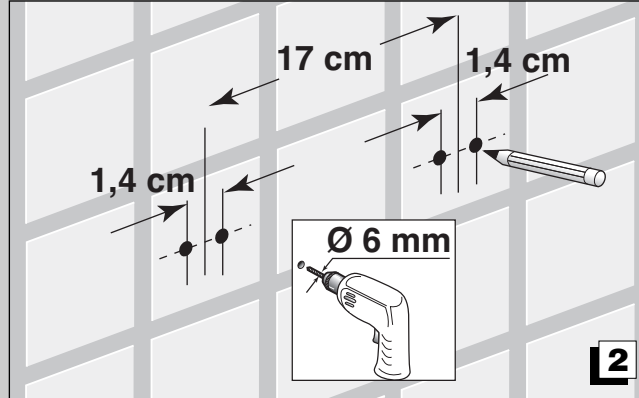
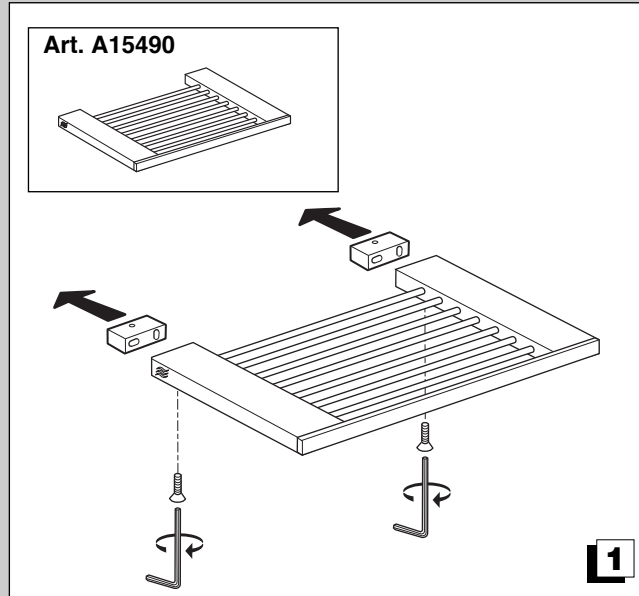
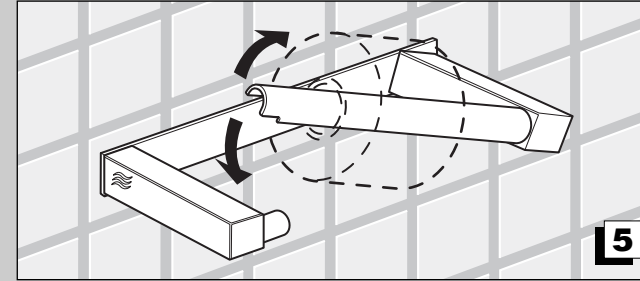
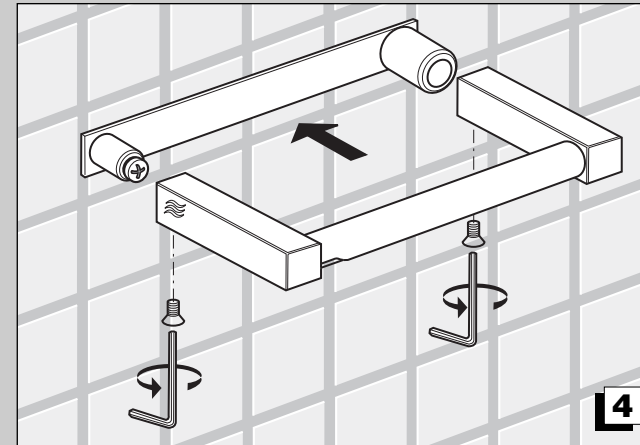
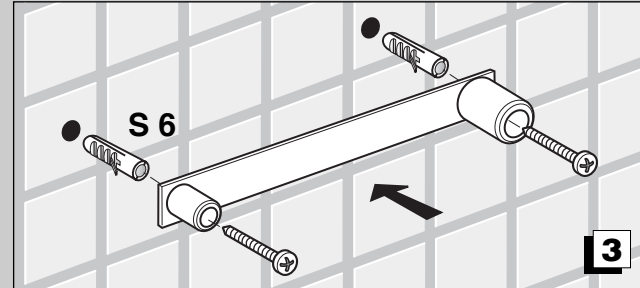
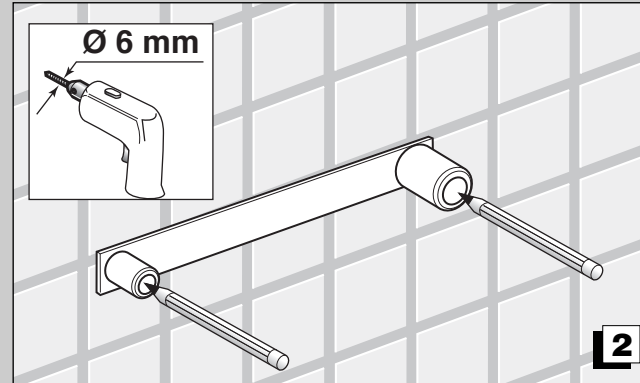
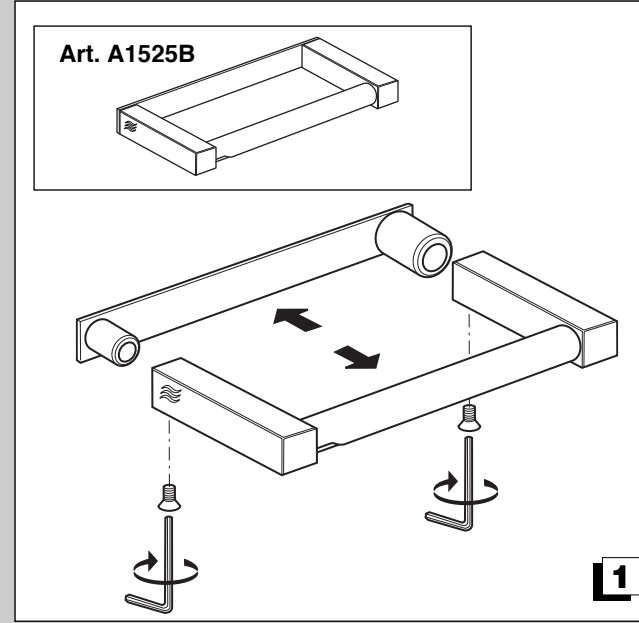
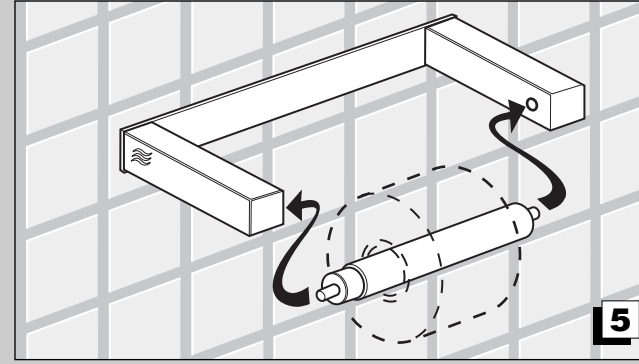
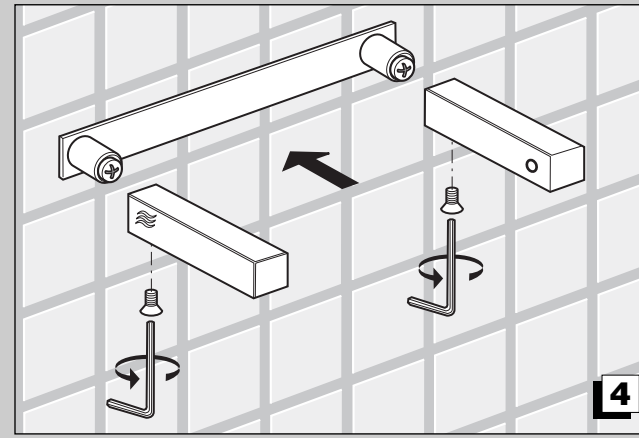
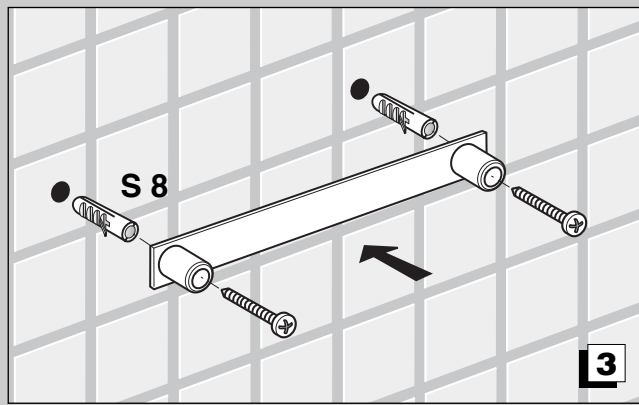
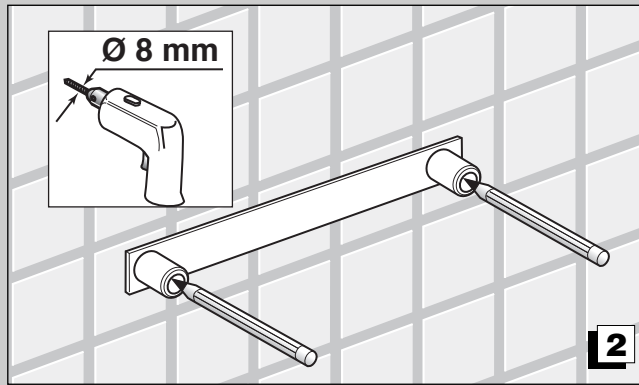
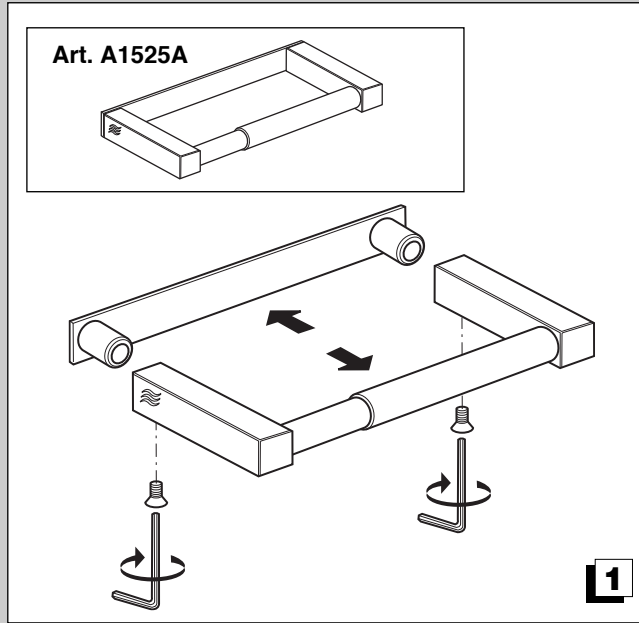

**I**

**PULIZIA**  
Qualità, processi tecnologici e materiali sono le caratteristiche che determinano l'alto livello dei nostri accessori. Comunque al fine di evitare alterazioni delle superfici è necessario seguire alcune avvertenze, pulendo qualsiasi finitura esclusivamente con acqua e sapone, asciugando con un panno morbido. Evitare stracci ruvidi, prodotti abrasivi, sostanze acide, ammoniacali, caustiche, candeggine, solventi e prodotti commerciali multiuso. Nel caso di contatto con tali sostanze occorre sciacquare ed asciugare subito le superfici. Ricordare che anche i vapori possono intaccare il metallo. Lavare periodicamente gli accessori vicino al wc per evitare corrosioni.

**GB**

**CLEANING**  
Quality, technological processes and materials are the features that determine the high standards of our accessories. However, to avoid surface alterations, it is necessary to follow a few guidelines. Clean all finishes exclusively with soap and water, and dry with a soft cloth. Do not use coarse cloths, abrasive products, acids, ammonia products, caustic substances, bleach or solvents. In case of contact with these substances, rinse surfaces immediately and wipe dry. Remember that even fumes can damage metal. Wash accessories next to the toilet bowl at regular intervals to avoid corrosion.

**F**

**NETTOYAGE**  
Nos accessoires se distinguent par le niveau élevé de leur qualité, de leur processus technologiques et de leurs matériaux. Toutefois, afin d'éviter d'abîmer les surfaces, il est nécessaire de suivre certaines recommandations, en nettoyant toutes les finitions uniquement avec de l'eau et du savon, en les essuyant avec un chiffon doux. Éviter d'utiliser des chiffons rugueux, des produits abrasifs, des substances acides, ammoniacales, caustiques, de l'eau de Javel, des solvants et des produits commerciaux multi-usages. En cas de contact avec ces substances, rincer et essuyer aussitôt les surfaces. Ne pas oublier que même les vapeurs peuvent corroder le métal. Laver régulièrement les accessoires à côté de la cuvette Wc afin d'éviter toute corrosion.

**D**

**REINIGUNG**  
Unserer Zubehörkomponenten zeichnen sich durch die hohe Qualität der Verfahrenstechniken und Materialien aus. Um Veränderungen der Oberflächen zu vermeiden, sind jedoch einige Hinweise zu beachten. Die Oberflächen dürfen nur mit Wasser und Seife gereinigt und müssen anschließend mit einem weichen Tuch abgetrocknet werden. Raue Lappen, Scheuermittel, säure- und ammoniakhaltige Mittel, Ätzmittel, Chlorbleiche sowie handelsübliche Vielzweck-Lösungsmittel sind zu vermeiden. Sollten die Oberflächen mit diesen Stoffen in Berührung kommen müssen sie sofort abgespült und abgetrocknet werden. Denken Sie daran, dass auch Dämpfe Metall angreifen können. Zur Vermeidung von Korrosion sind Zubehörteile in WC-Nähe regelmäßig abzusputzen.

**NL**

**REINIGING**  
Kwaliteit, technologische processen en materialen zijn de kenmerken die het hoge niveau van onze accessoires bepalen. Het is hoe dan ook noodzakelijk om, teneinde verandering van de oppervlakken te voorkomen, de aanwijzingen op te volgen, en alle afwerkingen uitsluitend met water en zeep schoon te maken en te drogen met een zachte doek. Gebruik geen ruwe doekjes, schuurmiddelen, zure, ammoniakhoudende of bijtende stoffen, bleekmiddelen, oplosmiddelen en multifunctionele reinigingsproducten. Als de oppervlakken hiermee in aanraking komen moet men ze onmiddellijk afspelen en drogen. Bedenk dat ook dampen het metaal kunnen aantasten. Reinig de accessoires in de buurt van de wc regelmatig om corrosie te voorkomen.

**E**

**LIMPIEZA**  
Calidad, procesos tecnológicos y materiales son los factores que determinan el elevado nivel de nuestros accesorios. De todas formas, para evitar que se alteren las superficies es preciso seguir algunos consejos: para limpiar cualquier tipo de acabado se usará exclusivamente agua y jabón, secándolo después con un paño suave. No se habrán de usar trapos ásperos, productos abrasivos, sustancias ácidas, amoniacales, cáusticas, lejía, disolventes ni tampoco productos comerciales multiuso. En caso de contacto con dichas sustancias habrá que aclarar y secar inmediatamente las superficies. Recuérdese también que los vapores pueden afectar a los metales. Límpiense periódicamente los accesorios cercanos al wc para evitar corrosiones.

**P**

**LIMPEZA**  
Qualidade, processos tecnológicos e materiais são as características que determinam o alto nível dos nossos acessórios. De qualquer forma, com o intuito de evitar as alterações das superfícies é necessário seguir algumas advertências, limpando qualquer acabamento exclusivamente com água e sabão, e secando com um pano macio. Evitar trapos ásperos, produtos abrasivos, substâncias ácidas, amoniacais, cáusticos, lixívia, solventes e produtos comerciais multiuso. Em caso de contacto com estas substâncias é necessário enxaguar imediatamente as superfícies. Lembre-se de que os vapores também podem danificar o metal. Lavar periodicamente os acessórios próximos à sanita para evitar corrosões.